



Reinforced Concrete

By: Prof. Dr. Haleem K. Hussain

University Of Basrah
Engineering College
Civil Engineering Department

E-Mail: haleem_bre@yahoo.com
haleem.albremani@gmail.com

Chapter I

Introduction



Reinforced Concrete Design I

The aim of this subject is to develop the ability of civil engineering students in analysis and design different type of reinforced concrete structures expose to different kind of loads (**static and dynamic**) using the design equation depending on the essential principals through understanding the procedures of analysis and design easily applied for different type of structures

At the end of this course, the student should be able to:

- State the basis of the analysis of the structure,
- State the objectives of the design of reinforced concrete structures,
- State the method of design of concrete structure,
- Express the design loads in terms of characteristic loads in ultimate strength and working stress methods,
- Define the characteristic load,
- Name the different loads, forces and effects to be considered in the design,
- State the basis of determining the combination of different loads acting on the structure
- Design the beam section for flexural and shear.
- Design the one-way slab.

Course I – syllabus

- 1- Chapter I: Introduction
- 2- Chapter II: Flexural Analysis Strength of Concrete Sections
- 3- Chapter III: Design of concrete Sections
- 4- CHAPTER IV: Design for Shear
- 5- Chapter V: Deflection and Control of Cracking
- 6- Chapter VI: Development Length
- 7- Chapter VII: One-way Slabs



References :

- 1- Structural Concrete Theory and Design , By Nadim Hasson, Akthem Aktham Al manseer , 6th Edition 2015
- 2- Reinforced concrete design , 7th Edition 2007 By Chu Kai Wang, Charles G salmon and Joe A Pincheire
- 3- Design of Reinforced concrete Structures , 2nd Edition 2008 By Mohammed Tharwat Ghonein, Vol. 3
- 4- Design of concrete Structure , 14th Edition 2010 By Arthur H. Nilson , Daved Derwin and Charles W. Dolan
- 5- Reinforced concrete design , 6th Edition 2009 By Edward G. Nawy
- 6- ACI Code 318- 2019



1. Concrete and Reinforced Concrete

Concrete is a mixture of sand, gravel, crushed rock, or other aggregates held together in a rocklike mass with a paste of cement and water. Sometimes one or more admixtures are added to change certain characteristics of the concrete such as its workability, durability, and time of hardening.

As with most rocklike substances, concrete has a high compressive strength and a very low tensile strength. Reinforced concrete is a combination of concrete and steel wherein the steel reinforcement provides the tensile strength lacking in the concrete. Steel reinforcing is also capable of resisting compression forces and is used in columns as well as in other situations.

1.1. Properties of Concrete

Some of properties of concrete are:

1.1.1. Compressive Strength

The compressive strength of concrete is determined by testing to failure at 28-day-old, concrete cylinders or cubs at a specified rate of loading.

f'_c : compressive strength of concrete for cylinders (ACI code)

f_{cu} : compressive strength of concrete for cubs (BS code)

f'_c =about 80% f_{cu}





compressive strength test
For cylinder



compressive strength test
for cube

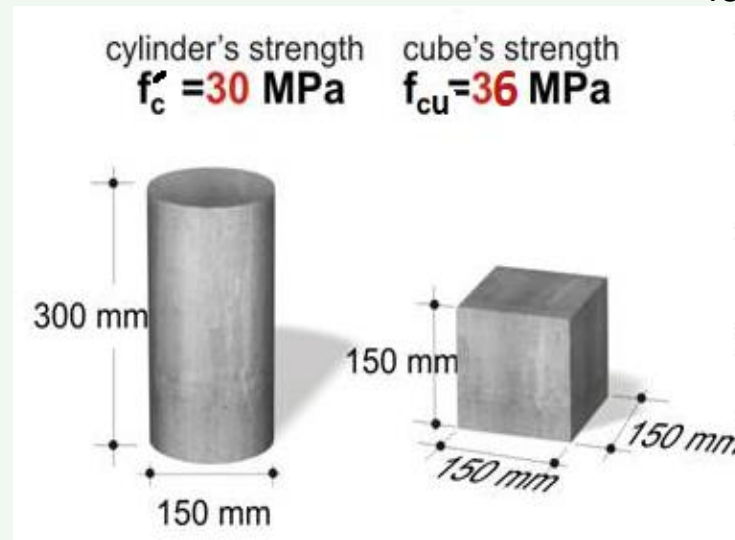

The stress–strain curves as shown below represent the results obtained from compression tests of sets of 28-day-old standard cylinders of varying strengths. You should carefully study these curves because they bring out several significant points:

- (a) The curves are roughly straight while the load is increased from zero to about **one-third to one-half** the concrete's **ultimate strength**.
- (b) Beyond this range the behavior of **concrete is nonlinear**. This lack of linearity of concrete stress–strain curves at higher stresses causes some problems in the structural analysis of concrete structures because their behavior is also nonlinear at higher stresses.
- (c) particular importance is the fact that regardless of strengths, **all the concretes reach their ultimate strengths at strains of about 0.002**.
- (d) Concrete does not have a definite yield strength; rather, the curves run smoothly on to the point of rupture at strains of from 0.003 to 0.004. It will be assumed for the purpose of future calculations in this text that concrete **fails at 0.003** (ACI 318M-14 section 22.2.2.1) or write (ACI 22.2.2.1).
- (e) Many tests have clearly shown that stress–strain curves of concrete cylinders are almost identical to those for the compression sides of beams.
- (f) It should be further noticed that the **weaker grades of concrete are less brittle** than the stronger ones—that is, they will take larger strains before breaking.

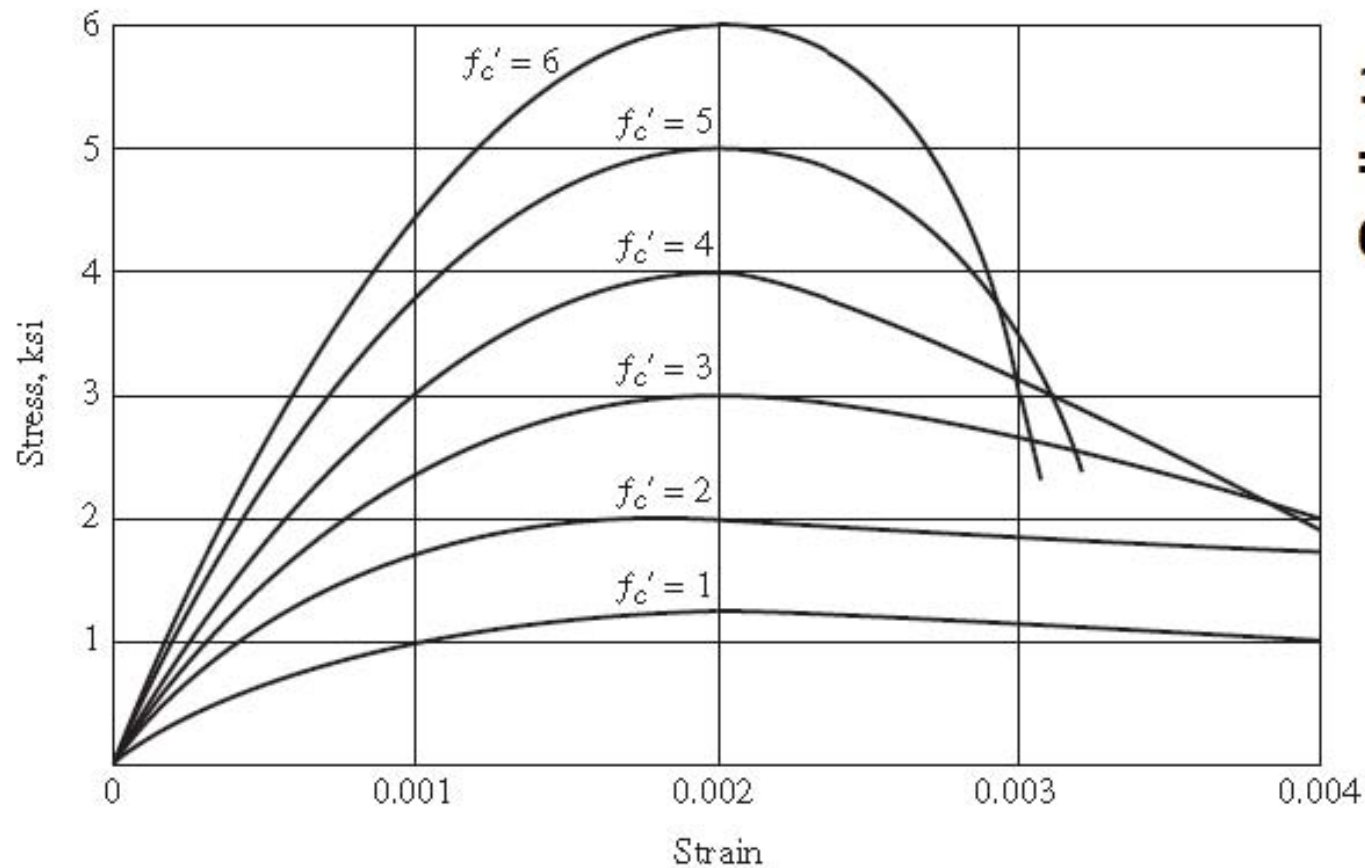

1 Ksi
=
6.895 MPa

$$\text{Stress } \sigma = \frac{P}{A}$$

$$\text{Strain } \epsilon = \frac{\Delta L}{L}$$

Typical concrete stress-strain curve, with short-term loading.

1.1.2. Tensile Strength of Concrete

Concrete is a brittle material, and it cannot resist the high tensile stresses that are important when considering cracking, shear, and torsional problems. The low tensile capacity can be attributed to the high stress concentrations in concrete under load, so that a very high stress is reached in some portions of the specimen, causing microscopic cracks, while the other parts of the specimen are subjected to low stress.

Direct tension tests are not reliable for predicting the tensile strength of concrete, due to minor misalignment and stress concentrations in the gripping devices. An indirect tension test is called the splitting test. In this test, the concrete cylinder is placed with its axis horizontal in a compression testing machine. The load is applied uniformly along two opposite lines on the surface of the cylinder through two plywood pads, as shown below. Considering an element on the vertical diameter and at a distance y from the top fibers, the element is subjected to a compressive stress.

$$f_c = \frac{2P}{\pi LD} \left(\frac{D^2}{y(D-y)} - 1 \right)$$

and a tensile stress

$$f'_{sp} = \frac{2P}{\pi LD}$$

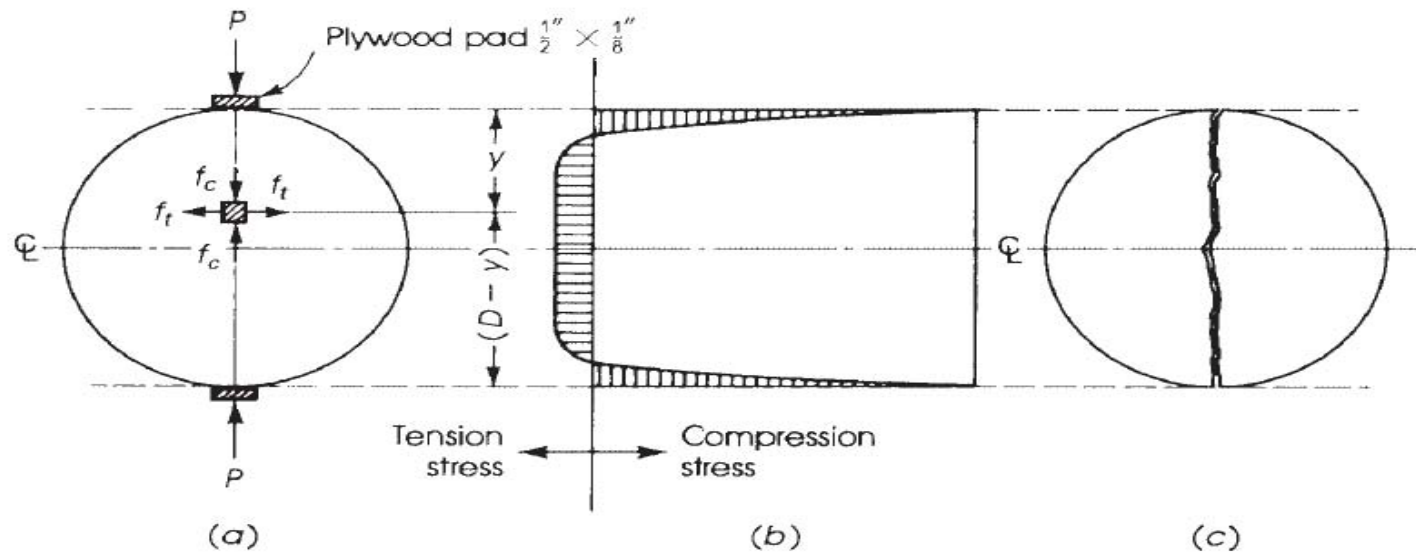

Cylinder splitting test [6]: (a) configuration of test, (b) distribution of horizontal stress, and (c) cylinder after testing.

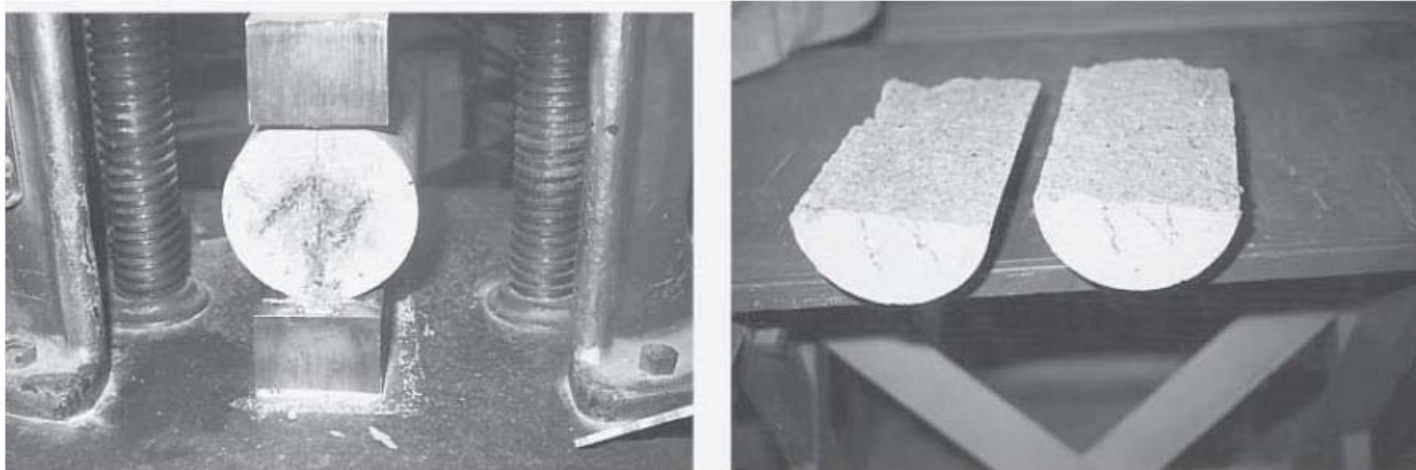

Concrete cylinder splitting test.

1.1.3. Flexural Strength (Modulus of Rupture) of concrete

Experiments on concrete beams have shown that **tensile strength in bending is greater** than the tensile stress obtained by direct or **splitting tests**. Flexural strength is expressed in terms of the modulus of rupture of concrete (f_r), which is the maximum tensile stress in concrete in bending.

The modulus of rupture can be calculated from the flexural formula used for elastic materials,

$$\sigma = f_c = M c / I, \text{ or } f_r = M c / I$$

by testing a plain concrete beam. **The beam (150 × 150 × 700 mm)**, is supported on a **(600-mm)** span and loaded to rupture by two loads on either side of the center. **A smaller beam of (100 × 100 × 500 mm)** on a (400-mm) span may also be used. The modulus of rupture of concrete ranges between 11 and 23% of the compressive strength.

The ACI Code, Section 19.2.3.1, prescribes the value of the modulus of rupture as

$$f_r = 0.62\lambda \sqrt{f'_c} \quad (N/mm^2)$$

Where the modification factor λ for type of concrete (ACI Table 19.2.4.2) is given as:

$$\lambda = \begin{cases} 1.0 & \text{for normal weight concrete} \\ 0.85 & \text{for sand - light weight concrete} \\ 0.75 & \text{for All light weight concrete} \end{cases}$$

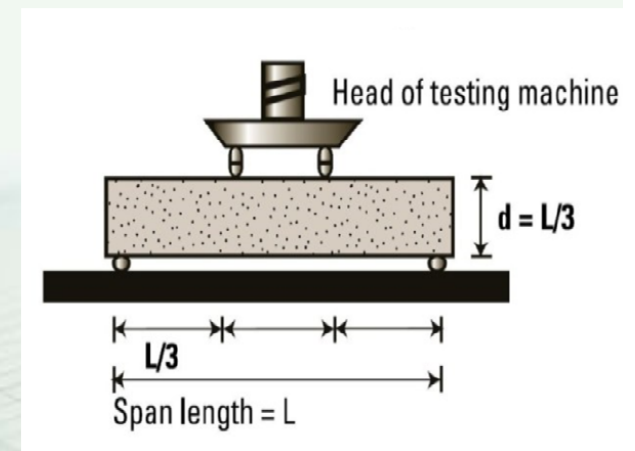

Linear interpolation shall be permitted between 0.85 and 1.0 on the basis of volumetric fractions, for concrete containing normal-weight fine aggregate and a blend of lightweight and normal-weight coarse aggregate.

The modulus of rupture as related to the strength obtained from the split test on cylinders may be taken.

1.1.4. Shear Strength of Concrete

Pure shear is seldom encountered in reinforced concrete members because it is usually accompanied by the action of normal forces. An element subjected to pure shear breaks transversely into two parts. Therefore, the concrete element must be strong enough to resist the applied shear forces.

Shear strength may be considered as 20 to 30% greater than the tensile strength of concrete, or about 12% of its compressive strength. The [ACI Code, Section 22.6.6.1](#), allows a nominal shear stress on plain concrete sections is:

$$= 0.17\lambda \sqrt{f'_c} \text{ N/mm}^2$$

1.1.5. Modulus of Elasticity of Concrete

Concrete has no clear-cut modulus of elasticity. Its value varies with different concrete strengths, concrete age, type of loading, and the characteristics and proportions of the cement and aggregates. Furthermore, there are several different definitions of the modulus:

- (a) The **initial modulus** is the slope of the stress–strain diagram at the **origin of the curve**.
- (b) The **tangent modulus** is the slope of a **tangent to the curve** at some point along the curve—for instance, at **50%** of the ultimate strength of the concrete.
- (c) The slope of a line drawn from the **origin to a point** on the curve somewhere between **25% and 50%** of its ultimate compressive strength is referred to as a **secant modulus**.
- (d) Another modulus, called the **apparent modulus** or the **long-term modulus**, is determined by using the stresses and strains obtained after the load has been applied for a certain **length of time**.

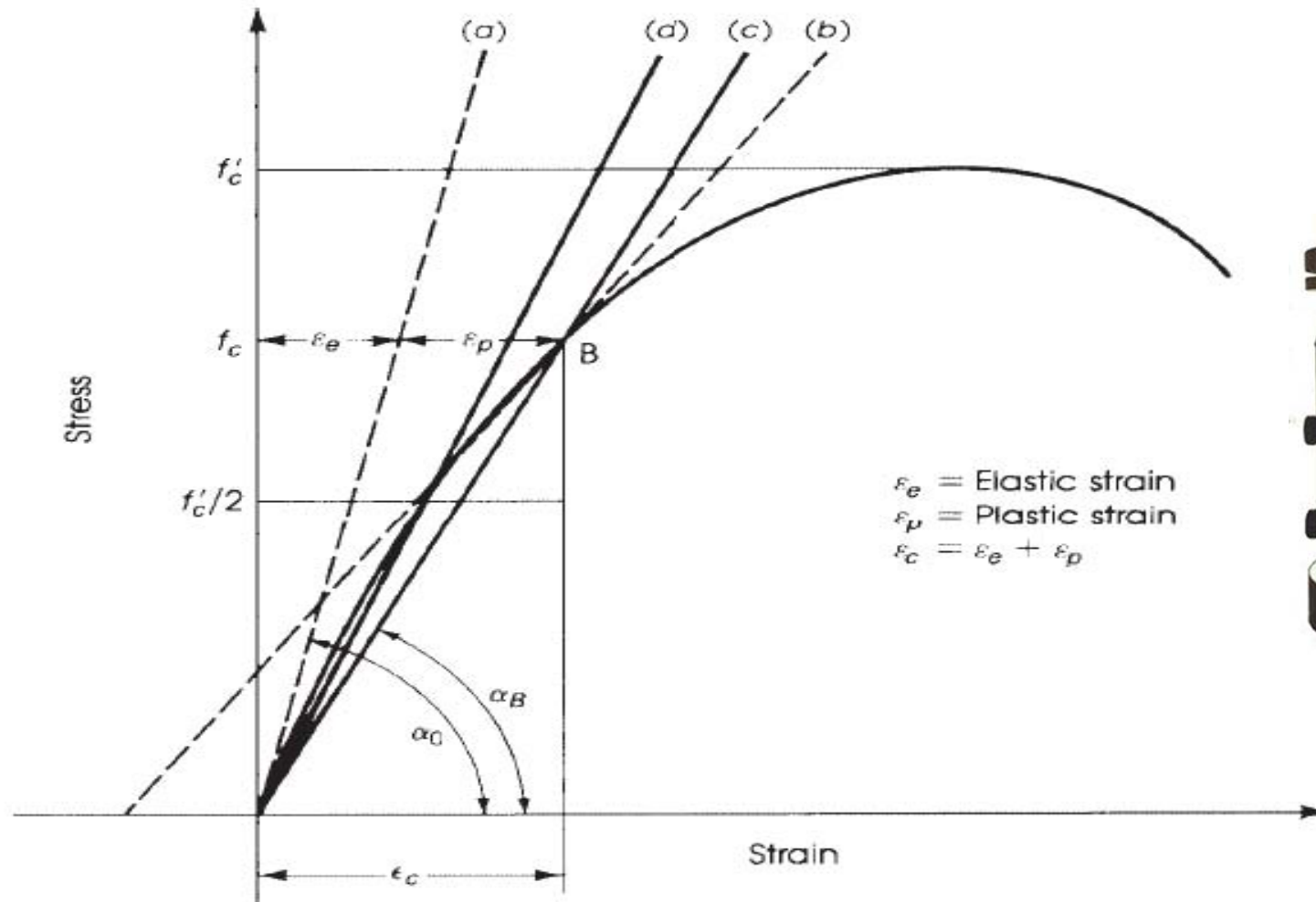

Stress-strain curve and modulus of elasticity of concrete. Lines *a-d* represent (a) initial tangent modulus, (b) tangent modulus at a stress, f_c , (c) secant modulus at a stress, f_c , and (d) secant modulus at a stress $f'_c/2$.

The ACI Code, Section (19.2.2.1.a), gives a simple formula for calculating the modulus of elasticity of **normal and lightweight** concrete considering the secant modulus at a level of stress, f_c equal to half the specified concrete strength, f'_c

$$E_c = 0.043 \omega^{1.5} \sqrt{f'_c} \text{ N/mm}^2$$

where ω = unit weight of concrete [between 1400 to 2600 kg/m³] and f'_c = specified compressive strength of a standard concrete cylinder. For **normal-weight concrete**. The ACI Code (19.2.2.1.b) allows the use of :

$$E_c = 4700 \sqrt{f'_c} \text{ N/mm}^2$$

1.1.6. Poisson's Ratio

Poisson's ratio μ is the ratio of the transverse to the longitudinal strains under axial stress within the elastic range. This ratio varies between **0.15 and 0.20** for both normal and lightweight concrete.

1.1.7. Shear Modulus

The modulus of elasticity of concrete in shear ranges from about **0.4 to 0.6** of the corresponding modulus in compression. From the theory of elasticity, the shear modulus is taken as follows

$$G_c = \frac{E_c}{2(1 + \mu)}$$

1.1.8. Modular Ratio

The modular ratio **n** is the ratio of the modulus of elasticity of steel to the modulus of elasticity of concrete:

$$n = E_s / E_c$$

1.1.9. Unit Weight of Concrete

The unit weight, w , of hardened normal concrete ordinarily used in buildings and similar structures depends on the concrete mix, maximum size and grading of aggregates, water–cement ratio, and strength of concrete. The following values of the unit weight of concrete may be used:

- 1 .Unit weight of **plain concrete** using maximum aggregate size of 3/4 in. (**20 mm**) varies between (**2320 to 2400 kg/m³**). For concrete of strength **less than (28 MPa)**, a value of (2320 kg/m³) can be used, whereas for **higher strength** concretes, w can be assumed to be equal to (**2400 kg/m³**).
- 2 .Unit weight of **plain concrete** of maximum aggregate size of 4 to 6 in. (**100 to 150 mm**) varies between (**2400 to 2560 kg/m³**). An average value of **2500 kg/m³** may be used.

3 .Unit weight of reinforced concrete, using about **0.7 to 1.5% of steel** in the concrete section, may be taken as **(2400 kg/m³)**. For **higher percentages** of steel, the unit weight, w , can be assumed to be **(2500 kg/m³)**.

4 .Unit weight of **lightweight concrete** used for fireproofing, masonry, or insulation purposes varies between **(320 and 1440 kg/m³)**. Concrete of upper values of 1440 kg/m³ or greater may be used for load-bearing concrete members.

The unit weight of heavy concrete varies between (3200 and 4300 kg/m³). Heavy concrete made with natural **barite aggregate** of 1.5 in. maximum size (38 mm) weighs about **(3600 kg/m³)**. Iron of sand and steel-punchings aggregate produce a unit weight of **(4320 kg/m³)**.

1.1.10. Volume Changes of Concrete

Shrinkage, Creep, and Expansion Due to Rise in Temperature

1.2. Steel Reinforcement

Reinforcement, usually in the form of steel bars, is placed in the concrete member, **mainly in the tension zone**, to resist the tensile forces resulting from external load on the member. Reinforcement is also used to increase the member's **compression resistance**. **Steel costs** more than concrete, but it has a **yield strength about 10 times** the compressive strength of concrete.

Longitudinal bars taking either tensile or compression forces in a concrete member are called **main reinforcement**. Additional reinforcement **in slabs**, in a direction perpendicular to the main reinforcement, is called **secondary**, or distribution, reinforcement. In reinforced concrete **beams**, another type of steel reinforcement is used, **transverse** to the direction of the main steel and bent in a box **or U shape**. These are called **stirrups**. Similar reinforcements are used in **columns**, where they are called **ties**.

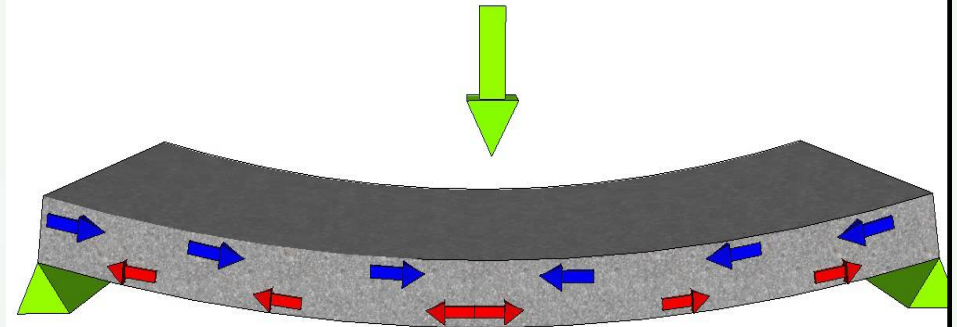

1.2.1. Types of Steel Reinforcement

Different types of steel reinforcement are used in various reinforced concrete members. These types can be classified as follows:

Round Bars. Round bars are used most widely for reinforced concrete. Round bars are available in a large range of diameters, from 1/4 in. (6 mm) to 1 3/8 in. (36 mm), plus two special types, 1 3/4 in. (45 mm) and 2 1/4 in. (57 mm). Round bars, depending on their surfaces, are either plain or deformed bars. **Plain bars** are used mainly for secondary reinforcement or in stirrups and ties. **Deformed bars** by either the continuous-line system or the number system. In the first system, one longitudinal line is added to the bar, in addition to the main ribs, to indicate the high-strength grade of 60 ksi (420 N/mm²), according to ASTM specification A 617. If only the main ribs are shown on the bar, without any additional lines, the steel is of the ordinary grade according to ASTM A 615 for the structural grade ($f_y = 40$ ksi, or 280 N/mm²). In the number system, the yield strength of the high-strength grades is marked clearly on every bar. For ordinary grades, no strength marks are indicated. The two types are shown in Fig. below.

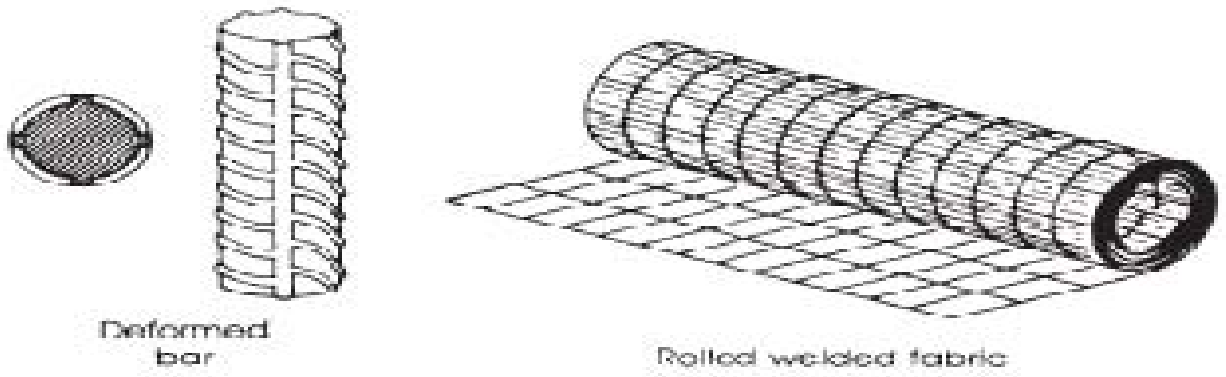
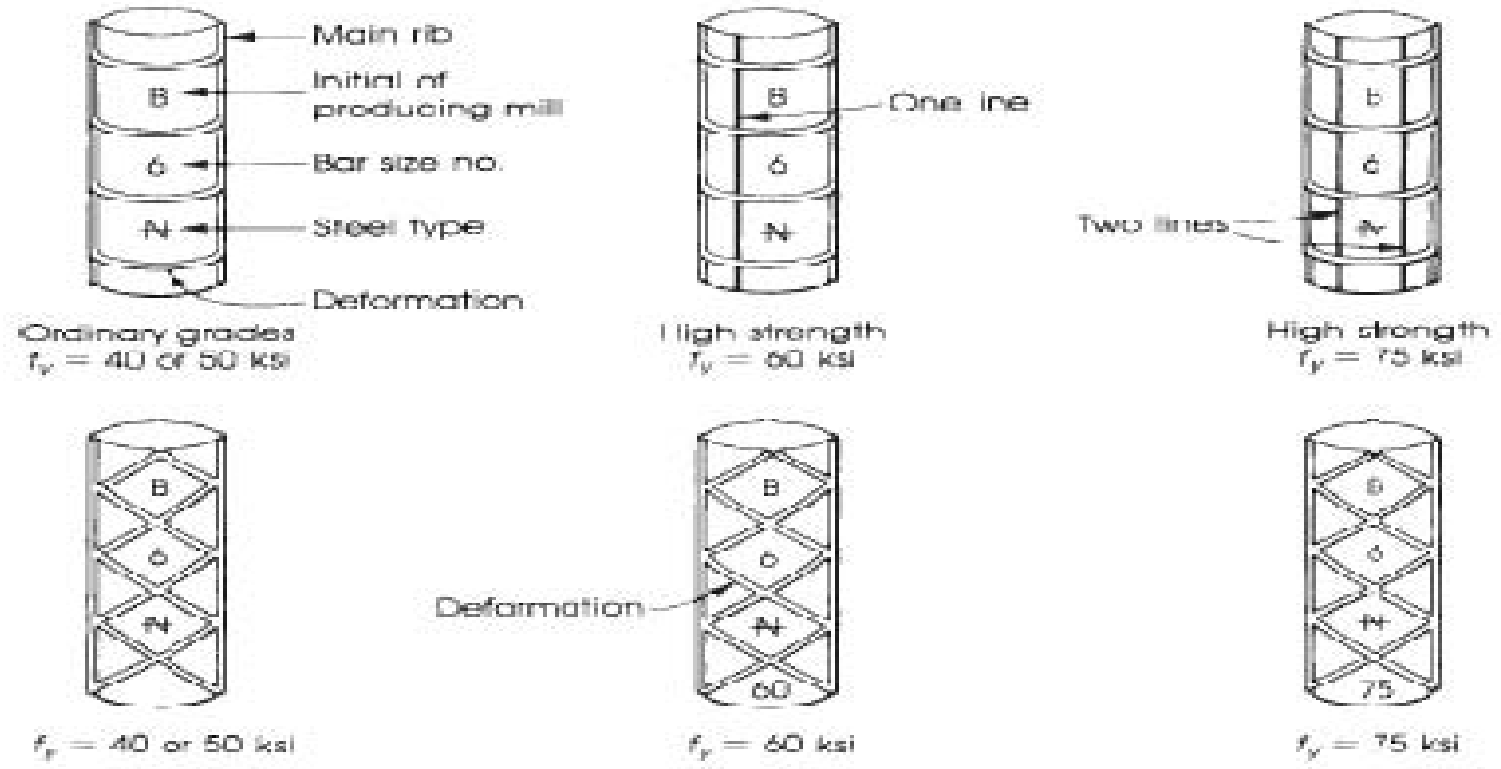

Some types of deformed bars and American standard bar marks.

1.2.2. Stress–Strain Curves of the steel

The most important factor affecting the mechanical properties and **stress–strain curve** of the steel is its **chemical composition**. The introduction of carbon and alloying additives in steel increases its strength but reduces its ductility.

Commercial steel rarely contains more than 1.2% carbon; the proportion of carbon used in structural steels varies between **0.2 and 0.3%**. Two other properties are of interest in the design of reinforced concrete structures; the first is the modulus of elasticity, **E_s** . It has been shown that the modulus of elasticity is constant for all types of steel. The ACI Code has adopted a value of **$E_s = 29 \times 10^6$ psi (2.0×10^5 MPa)**. The modulus of elasticity is the slope of the stress–strain curve in the elastic range up to the proportional limit; $E_s = \text{stress/strain}$. Second is the **yield strength, f_y** .

Typical stress–strain curves for some steel bars are shown in Fig. below. In high-tensile steel, a definite yield point may not show on the stress–strain curve. In this case, ultimate strength is reached gradually under an increase of stress (Fig. below). The yield strength or proof stress is considered the stress that leaves a residual strain **of 0.2% on the release of load**, or a total strain of 0.5 to 0.6% under load



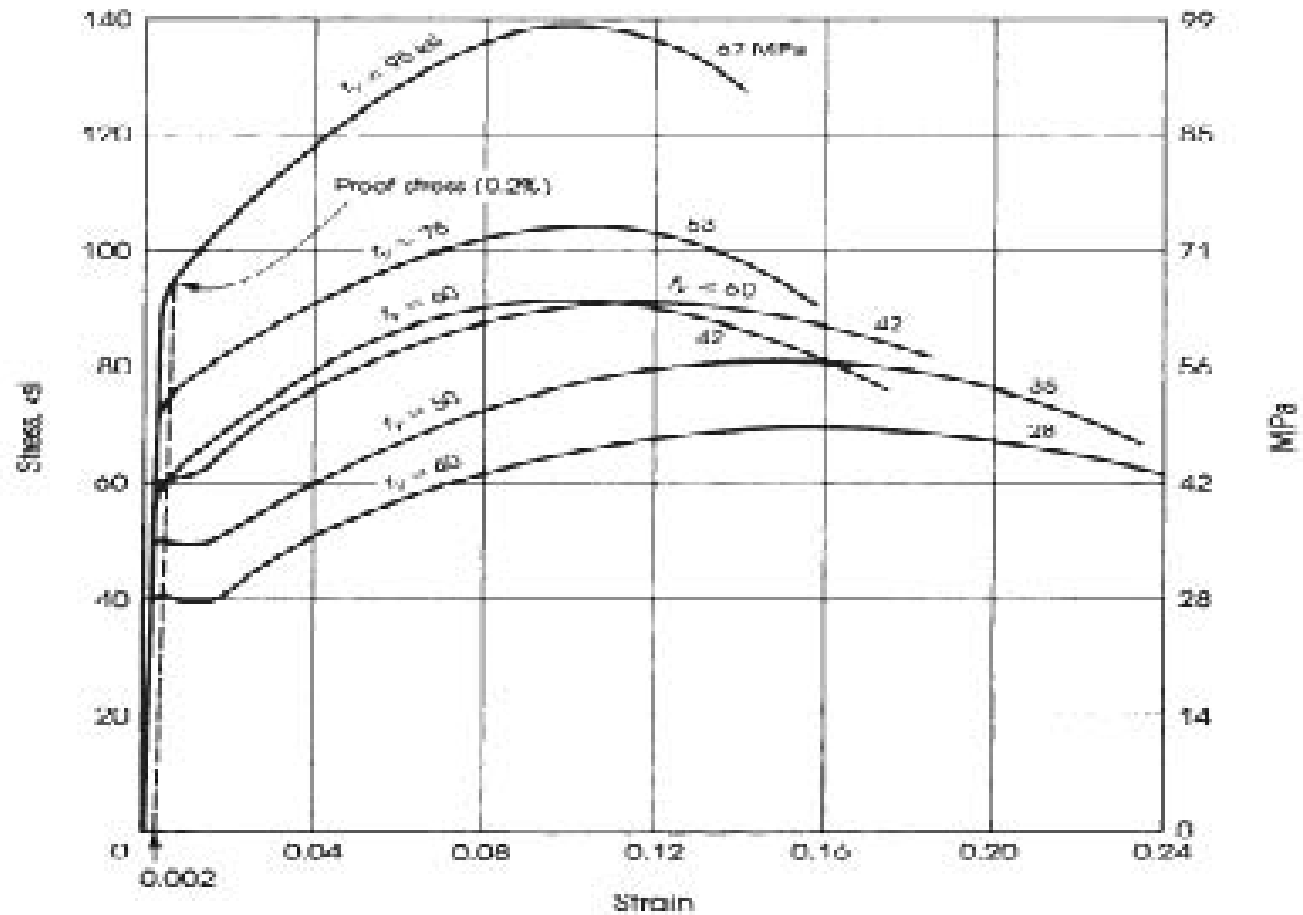

Typical stress-strain curves for some reinforcing steel bars of different grades. Note that 60-ksi steel may or may not show a definite yield point.

2. DESIGN PHILOSOPHY AND CONCEPTS

The design of a structure may be regarded as the process of selecting the **proper materials** and proportioning the different elements of the structure according to state-of-the-art engineering science and technology. In order to fulfill its purpose, the structure must meet the conditions of:

safety, serviceability, economy, and functionality.

The ACI Code emphasizes the **unified design method (UDM)** which based on the strength of structural members assuming a failure condition, whether due to the crushing of the concrete or to the yield of the reinforcing steel bars. Although there is some additional strength in the bars after yielding (due to strain hardening), this additional strength is not considered in the analysis of reinforced concrete members. In this approach, the actual loads, or working loads, are multiplied by load factors to obtain the factored design loads. The load factors represent a high percentage of the factor for safety required in the design.

The basic method that is not commonly used (now) is called the **working stress design** or the elastic design method. The design concept is based on the elastic theory assuming a straight-line stress distribution along the depth of the concrete section under service loads. The members are proportioned on the basis of certain allowable stresses in concrete and steel. The allowable stresses are fractions of the crushing strength of concrete and yield strength of steel. **This method has been deleted from the ACI Code.** The application of this approach is still used in the design of pre-stressed concrete members under service load conditions.

3. CODES OF PRACTICE

The design engineer is usually guided by specifications called the codes of practice. Engineering specifications are set up by various organizations to represent the minimum requirements necessary for the safety of the public, although they are not necessarily for the purpose of restricting engineers.

Most codes specify design loads, allowable stresses, material quality, construction types, and other requirements for building construction.

The most significant standard for structural concrete design in the United States is the Building Code Requirements for Structural Concrete,

- 1- ACI 318, or the ACI Code.
- 2- International building Code (IBC),
- 3-The American Society of Civil Engineers standard ASCE 7,
- 4- The American Association of State Highway and Transportation Officials (AASHTO).
- 5- American Society for Testing and Materials (ASTM).
- 6- American Railway Engineering Association (AREA).
- 7- Iraqi Standards.



Thank You.....

