

Evaluation of Genetic Diversity Uses SSR and ISSR Markers on Date Palm Cultivars that Propagated through tissue culture and vegetative propagation.

Al-hamza A.M. Al-Salim^{1*}, Aqeel A. Suhaim¹ & Osama N. Jaffer²

¹ Department of Horticulture and Landscape, College of Agriculture, University of Basrah, Iraq

² Date Palm Research Center, University of Basrah, Iraq

*Corresponding author email: A.A.M.: alhamza.abdulzahra@uobasrah.edu.iq, A.A.S.: aqeel.suhaim@uobasrah.edu.iq, O.N.J.: almeer@uobasrah.edu.iq

Received 7th October 2024; Accepted 28th January 2025; Available online 24th August 2025

Abstract: The spread of tissue culture date palm cultivation in Iraq in recent years has played an important role in reviving date palm cultivation. To study the genetic diversity of tissue culture date palm and match them with some Iraqi cultivars molecular markers for (SSR) and (ISSR) were used. The current study was conducted on ten date palm cultivars (five tissue-cultured cultivars which are (Barhi, Saqai, Khalas, Zamli, and Maghrebi), and five vegetatively propagated cultivars which are (Barhi, Hasawi, Breem, Dieri, and Shukr). Five primers were used for ISSR technique (ubc815, ubc842, ubc858, 834, 825) and five primers for the SSR technique (SSR009, SSR016, 103270, GI298295793). The results were analyzed using Jaccard's coefficient, and a dendrogram using the UPGMA method of NTSYS-PC program. ISSR results showed that 28 polymorphic bands and 18 monomorphic bands. The efficiency of the primers ranged between (14.2-25) %, polymorphism (57.1-100) . Except for primer 834, its indices decreased to the lowest level and reached (20%, 17.8 %) respectively. SSR results showed 35 polymorphic bands and 34 monomorphic bands. The efficiency of the primers ranged between (14.28-100) %, polymorphism (80-100) % . Except for primer GI298295793, its efficiency decreased to 8.57% . It is concluded from the study that tissue culture date palm cultivars propagated through plant tissue culture did not show significant genetic variation among themselves, Therefore, this method can be adopted for productive propagation for date palms.

Keywords: Date palm, Genetic diversity, Molecular markers ISSR,SSR,tissue culture.

Introduction

Palm tree cultivation is widespread in Iraq and the Arab world. There are numerous varieties of date palms, including commercial varieties whose dates are exported internationally and account for 85% of the total number of palm trees (Al-Hamoud *et al.*, 2023; Salah *et al.*,

2024). Date palm tree reproduces through sexual reproduction (by seed) and vegetative reproduction through offshoots. A modern method of vegetative propagation is tissue culture, which produces a relatively large number of plants genetically similar to the

parent plant(Al-Khayri & Ibraheem, 2014; Al-Qatrani *et al.*, 2021).

Plants propagated through tissue culture are produced in somatic embryogenesis((Al-Qatrani *et al.*, 2023; Suhim *et al.*, 2023)) or direct organogenesis(Alrazaq *et al.*, 2023). The rate of genetic variation and differences in tissue-culture of date palms depends on many factors, including the propagation method used, the genetic makeup, the plant part used for propagation, and other factors(Ibrahim *et al.*, 2023). Genetic diversity refers to the variation in genes within plant species. Individuals within that species exhibit different phenotypic traits, reflecting the genetic diversity in their hereditary characteristics(Khouloussa *et al.*, 2023). Genetic markers are divided into several categories, including molecular markers such as DNA markers, and morphological markers. Morphological markers were the first to be used in studying genetic diversity(Begna & Yesuf, 2021).

Determining the genetic relationship between date palm cultivars is paramount in characterizing the genetic origins of date palm trees and in breeding programs. A genetic marker represents a crucial and unique characteristic that serves as a tool in genetically analyzing cultivars and identifying genetic diversity (Sabir *et al.*, 2014). Molecular markers express data derived from DNA molecules. The tags facilitate individuals who are outstanding in the progression of DNA profiles and insights into the genetic variation between taxa. Analyzing the genome and indexing the differences in coding and non-coding regions will produce information related to polymorphism. The development of various molecular markers has significantly progressed since the introduction of polymerase chain reaction (PCR). This

technique is predicated on amplifying targeted DNA sequences, utilizing specific or random primers tailored for this function. As a result, these markers can identify numerous loci, each potentially harboring multiple alleles.(Bhattarai *et al.*, 2023).

Simple Sequence Repeats (SSR) technology, often called Simple Tagged Microsatellite Sites (STMS), represents a second-generation and contemporary DNA marker. These markers exhibit a significant degree of polymorphism. SSRs are adept at identifying variations within DNA regions characterized by simple sequence repeats. SSR technology has been employed to develop genetic linkage maps for numerous significant traits. Additionally, it has facilitated the differentiation of species, the determination of gender, and the clarification of evolutionary relationships. Compared to alternative markers, SSR is regarded as the most efficient method for investigating genetic diversity and identifying genetic fingerprints.(Zhu *et al.*, 2016).

Molecular markers are regarded as effective instruments for identifying genetic variations. Various methodologies have been employed, including Random Amplified Polymorphic DNA (RAPD).(Al-Khalifah & Askari, 2003), Inter-Simple Sequence Repeats (ISSR)(El-Kosary *et al.*, 2023), and Amplified Fragment Length Polymorphism (AFLP) (Rhouma *et al.*, 2007). Research indicates significant polymorphism exists among various date palm cultivars. The Simple Sequence Repeats (SSR) method has proven to be the most effective technique for assessing the genetic variations within these cultivars.(Al Khazraji *et al.*, 2021)

Ibrahimi *et al.*, (2024) undertook a research investigation to uncover genetic variations among male date palm trees in the Kingdom of

Morocco. Utilizing 10 SSR primers, the researchers generated 248 amplified bands, of which 234 were identified as polymorphic, accounting for 93.99% of the total. The findings of this study indicated a significant level of genetic diversity within the genetic profiles of Moroccan male date palm trees (Khoulassa *et al.*, 2023). The research focused on the genetic diversity of Moroccan date palms through the application of SSR technology, utilizing 13 primers that produced 208 amplified bands, corresponding to an average of 16 bands per primer. The analysis of the genetic tree indicated that the Moroccan cultivars examined could be categorized into four separate groups. Inter-Simple Sequence Repeats (ISSR) technology is recognized as a component of the Third Generation of DNA markers. (Kumar *et al.*, 2019). A semi-random marker is utilized to amplify specific DNA regions located between two microsatellite loci by applying polymerase chain reaction (PCR) and a single primer complementary to the target microsatellite. Inter-simple sequence repeat (ISSR) markers exhibit differences from simple sequence repeat (SSR) markers regarding their productivity and level of polymorphism. Additionally, the efficacy of ISSR has been demonstrated across a wide array of plant species and significant cultivars. (Al Khazraji *et al.*, 2021).

El Kadri *et al.*, (2019) A research investigation examined the genetic diversity among male Tunisian date palms. This analysis involved 20 male cultivars and utilized 10 ISSR primers for the assessment. The findings indicated that the genetic similarity coefficients varied between 0.491 and 0.873, suggesting the establishment of genetically related clusters. The phylogenetic tree analysis further divided the cultivars into 5 main groups. Some results have

shown the effectiveness of ISSR technology in detecting molecular polymorphism in date palms, which means that the ISSR marker has a high discriminatory power (Kadri *et al.*, 2022).

This study was proposed because there have been few studies on the genetic conformity of tissue-cultured and vegetative date palm cultivars in southern Iraq.

Materials & Methods

The research was carried out at the College of Agriculture, University of Basrah, in 2023. Ten date palm cultivars of economic and productive importance cultivated in northern Basrah Governorate were selected. Five cultivars were propagated using plant tissue culture techniques (Barhi, Saq'i, Khalas, Zamli, and Maghribi), and five cultivars were propagated vegetatively (Barhi, Hasawi, Brem, Dery, and Shukr), as shown in Table (1).

Table (1): Name, Region, and Code of the Studied Cultivars

No.	Name	Code	Geographical distribution
	propagated using plant tissue culture		
1	Barhi	BRTSS	North basrah(qurna)
2	Saqai	SQTSS	North Basrah(masahb)
3	Khalas	KHTSS	North Basrah(masahb)
4	Zamli	ZATSS	North Basrah(sadeeq)
5	Maghrebi	MGTTSS	North Basrah(deer)
	propagated vegetatively		
6	Barhi	BRVEG	North basrah(qurna)
7	Hasawi	HAVEG	North basrah(qurna)
8	Breem	BEVEG	North basrah(deer)
9	Dieri	DRVEG	North basrah(sadeeq)
10	Shukr	SHVEG	North basrah(qurna)

The examined regions account for over 50% of the varieties under investigation. The study involved 30 date palm trees, averaging three trees per variety.

DNA Extraction

DNA extraction was performed at Wahj Al-DNA Company for Qualification and Training/ Department of Molecular Biology/ Baghdad /Iraq, using the ZR Plant / Seed DNA MiniPrep™ D 6020 - Zymo / USA kit. DNA was extracted from the young leaves of the cultivars, and the cultivars were coded (Table 1), The process involved measuring the purity and concentration of DNA using a Nanodrop-spectrophotometer at a wavelength of 260/280 nanometers (fig 1) (Sukumaran, 2011).

Table (2): The concentration and purity of the DNA of date palm cultivars

Sample ID	Code	Nucleic acid con. ($\mu\text{g}\cdot\text{ml}^{-1}$)	260 / 280 purity
1	BRTSS	26.4	0.998
2	SQTSS	30.0	1.154
3	KHTSS	26.1	1.002
4	ZATSS	31.0	1.165
5	MGTSS	27.7	1.018
6	BRVEG	27.3	1.024
7	HAVEG	29.6	1.126
8	BEVEG	29.5	1.152
9	DRVEG	27.5	1.096
10	SHVEG	26.6	1.113

Sample Preparation

A total of 3 μl of the loading buffer (Intron / Korea) was combined with 5 μl of the DNA sample intended for electrophoresis (loading dye). Following this mixing step, the resulting solution was loaded into the gel wells. An electric current of 7 V/cm was applied for 1 to 2 hours, until the dye migrated to the opposite end of the gel. Subsequently, the gel was examined using a UV light source at a wavelength of 336 nm after being immersed in a solution containing 3 μl of Red Safe Nucleic Acid Staining Solution and 500 ml of distilled water.

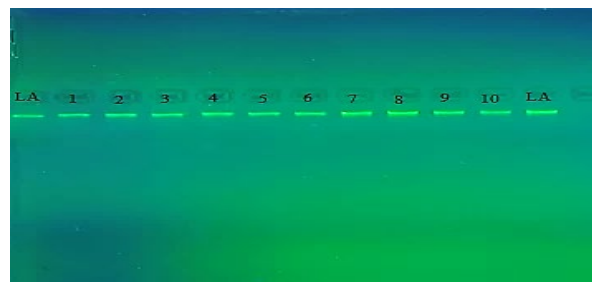

Fig. (1): illustrates the gel electrophoresis of genomic DNA extraction, conducted using a 1% agarose gel at a voltage of 5 volts per centimeter for 30 minutes

ISSR –PCR amplification

Five primers (Alpha DNA, USA) were selected for the DNA amplification by ISSR-PCR (Ibrahimi *et al.*, 2024) (Table 3). DNA amplification was performed using a reaction volume of 25 μl , which included 12.5 μl of 1X Go Taq® Green Master Mix (Promega-USA). This master mix contained 1.5 mM MgCl_2 , 10 mM Tris-HCl, 50 mM KCl, 200 μM of each deoxynucleotide triphosphate, and 1 unit of DNA polymerase. Additionally, 1.5 μL of primer ($10 \mu\text{mol ml}^{-1}$), 9.5 μL of nuclease-free water, and 1.5 μl of template DNA ($100 \mu\text{g ml}^{-1}$) were incorporated into the mixture. The amplification reactions were carried out in a Multigene™ Gradient Thermal Cycler (Labnet International, Korea) under the following conditions: an initial denaturation cycle at 94°C for 5 minutes, followed by 45 cycles comprising a denaturation phase at 94°C for 1 minute, an annealing phase at 36°C for 1 minute, and an extension phase at 72°C for 2 minutes. A final extension step was conducted at 72°C for 10 minutes. The resulting ISSR-PCR products were analyzed via electrophoresis on a 1% agarose gel, with a 1Kb DNA ladder (SiZer DNA Markers, Intron) included for reference. Visualization of the bands was accomplished by staining with $0.5 \mu\text{g mL}^{-1}$ ethidium bromide for 15 to 30 minutes. The gel images were digitally recorded using a gel documentation system,

and the molecular weight of the ISSR-PCR products was determined by comparing their sizes to those of DNA fragments from a 1 Kb

DNA ladder using the computer software Photo-CaptMwt version 10.01(Ngezahayo *et al.*, 2007)

Table (3): The ISSR primers and their characteristics

No.	Primer	Sequence	Tm (°C)	GC(%)
1	UBC815	CTCTCTCTCTCTCTG	46.8	52.9
2	UBC842	GAGAGAGAGAGAGAGAYG	48.8	52.8
3	UBC858	TGTGTGTGTGTGTGTGRT	53.1	47.2
4	834	AGAGAGAGAGAGAGAGYT	49.2	47.2
5	825	ACACACACACACACT	51.4	47.1

SSR-PCR Amplification

A 5 date-palm specific SSR primer pairs developed by (Feng *et al.*, 2016), (Table 4), Amplify the DNA using the same method followed in ISSR-PCR. The SSR-PCR products were subjected to electrophoresis using a 1% agarose gel, along with the inclusion of a 1Kb DNA ladder (SiZer DNA Markers (intron). The products were visualized

through staining with ethidium bromide at a concentration of 0.5 $\mu\text{g ml}^{-1}$ for 15 to 30 minutes. The gel images were digitally recorded using a gel documentation system, and the molecular weight of the ISSR-PCR products was determined by comparing their sizes to those of DNA fragments from a 1 Kb DNA ladder using the computer software Photo-Capt Mwt version 10.01(Cerasela *et al.*, 2011)

Table (4): The SSR primers and their characteristics

No.	Primer	Sequence	Tm (°C)	GC(%)
1	SSR009F	AGTGATGATGAATTGAAAGAGC	51.1	36.4
	SSR009R	CTCTCAAGTGTGGAAGGAACTC	53.1	45.5
2	SSR016F	GAATACTAAATGGGTGGAAGAA	50.1	36.4
	SSR016R	GCAAATAGATGTCCTTTAGGG	50.8	42.9
3	1036F	CTTTGGTAAGCGAAGGCTGT	55.5	50
	1036R	GCCATTTGTAAGCGGTTTGT	54.3	45
4	270F	AGGTGGAATACTGTGCGG	55.3	50
	270R	TGTTTCTGCACCTCAACAGC	55.9	50
5	gi298295793F	ATAGAATTCCTCCGACGACAA	53.4	45
	gi298295793R	GGCGGTTGAGATTGATAGGA	54.3	50

Data Analysis

Polymorphic bands were accurately quantified using the gel documentation system software, with scoring conducted for each genotype. Each distinct reproducible polymorphic DNA band located at a specific position on the gel was considered an individual character and recorded as either present (1) or absent (0), creating a binary data matrix. Data were then computed with the SPSS program to produce a genetic distance matrix which assesses the similarity between any two populations based on the number of generated bands using Jaccard's similarity coefficient

Genetic Distance = $1 - \left(\frac{2 \cdot N_{xy}}{N_y + N_x} \right)$, (Atienzar *et al.*, 1999)

Since Genetic Distance, represents the genetic distance, N_{xy} represents the number of bands shared between the two samples x and y , N_x represents the total number of bands in sample x , and N_y represents the total number of bands in sample y . A cluster analysis diagram was drawn according to the UPGMA method using the ready-made NTSYS-pc program (Numerical Taxonomy System) to obtain a

phylogenetic tree or genetic distance tree (Otu & Sayood, 2003).

Results & Discussion**Genetic diversity analysis**

ISSR results showed 28 polymorphic bands and 18 monomorphic bands. The efficiency of the primers ranged between (14.28-25)%, polymorphism (57.14-100)%, and discriminatory power (22.22-27.77)%. Except for primer 834, its indices decreased to the lowest level and reached (20%, 17.85%, and 5.55%), respectively (table 1 and figure 2). Based on the dendrogram (figure 3), the cultivars were clustered into three groups. The first group included (Saqai, Zamli, tissue culture Barhi, vegetative Barhi, and Maghrebi) with a similarity percentage ranging between (0.93-0.95)%. The second group included (Hasawi, Breem, Khalas, and Shukr) with a similarity percentage of (0.88-0.90)%. The third group included only the cultivar Dieri

Table (5): The total count of polymorphic loci and the level of polymorphism produced by five primers during ISSR-PCR reactions across ten varieties of date palms.

Primer	Number of Loci	Polymorphic Loci	Polymorphism (%)	Primer Efficiency%	Discrimination Power%
UBC815	5	5	100	17.85714	27.77778
UBC842	7	4	57.14286	25	22.22222
UBC858	4	4	100	14.28571	22.22222
834	5	1	20	17.85714	5.55556
825	7	4	57.14286	25	22.22222
	28	18			

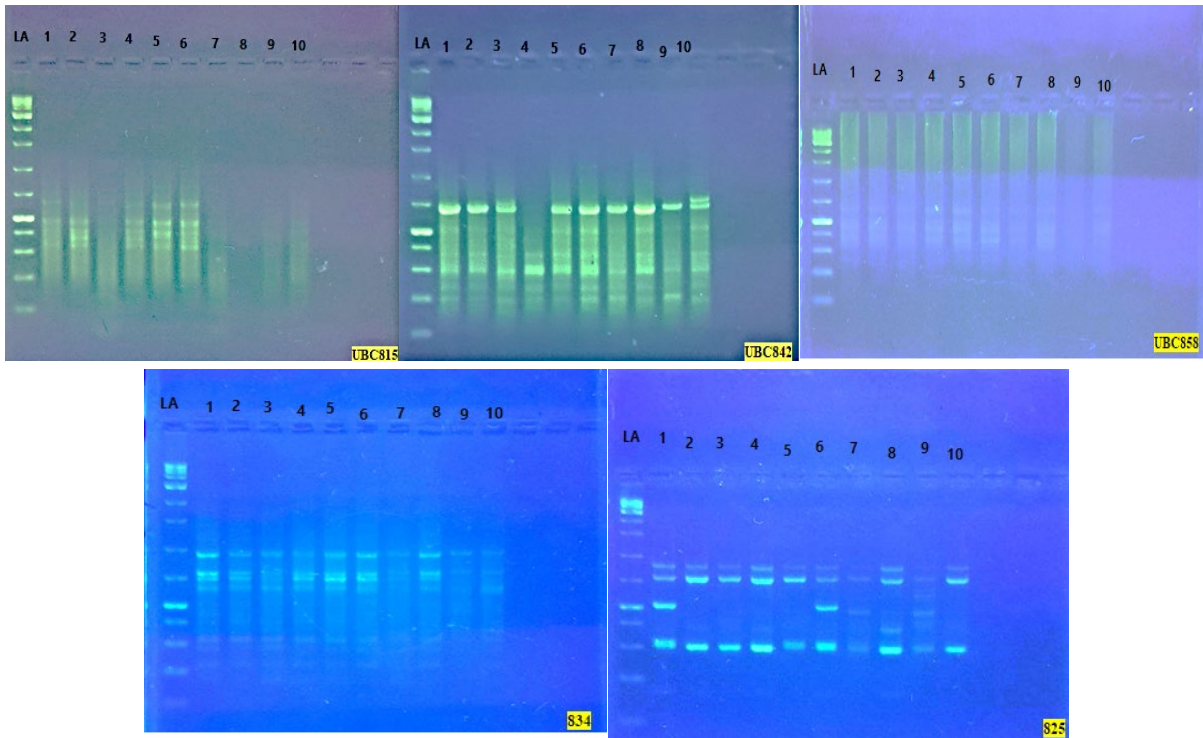

Fig. (2): The PCR-ISSR primers electrophoresis on a 2% agarose gel for 1 : 30 hour, utilizing 1x TBE buffer. A DNA ladder of 1000 base pairs was employed as a molecular weight marker.

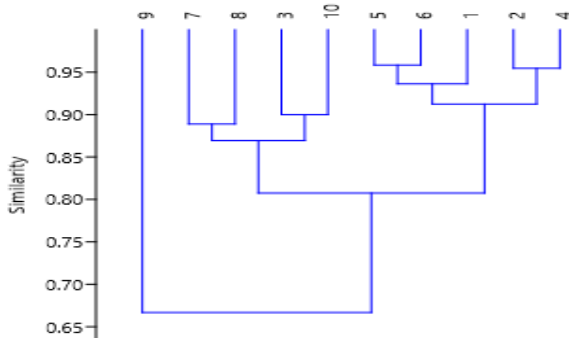

Fig.(3): A dendrogram illustrating the phylogenetic relationships among ten date palm cultivars was constructed using Nei and Li's similarity coefficient, derived from five ISSR primers

SSR results showed 35 polymorphic bands and 34 monomorphic bands. The efficiency of the

primers ranged between (14.28-100) %, polymorphism (80-100) %, and discriminatory power (11.76-32.35) %. Except for primer GI298295793, its efficiency decreased to 8.57% and its discriminatory power to 8.82% (table 6 and Figure 4). Based on the dendrogram (figure 5), the cultivars were clustered into three groups. The first group included (Saqai, tissue culture Barhi, and Khalas) with a similarity percentage ranging between (0.51-0.71) %. The second group included (, Breem, Maghrebi, Zamli and vegetative Barhi) with a similarity percentage of (0.37-0.76) %. The third group included the cultivars (Shukr, Dieri and Hasawi) with a similarity percentage of (0.42-0.75) %.

Table (6): The total count of polymorphic loci and the level of polymorphism produced by five primers during SSR-PCR reactions across ten varieties of date palms.

Primer	Number of Loci	Polymorphic Loci	Polymorphism (%)	Primer Efficiency%	Discrimination Power%
SSR009	5	4	80	14.28571	11.76471
SSR016	11	11	100	31.42857	32.35294
1036	9	9	100	25.71429	26.47059
270	7	7	100	20	20.58824
GI298295793	3	3	100	8.571429	8.823529
	35	34			

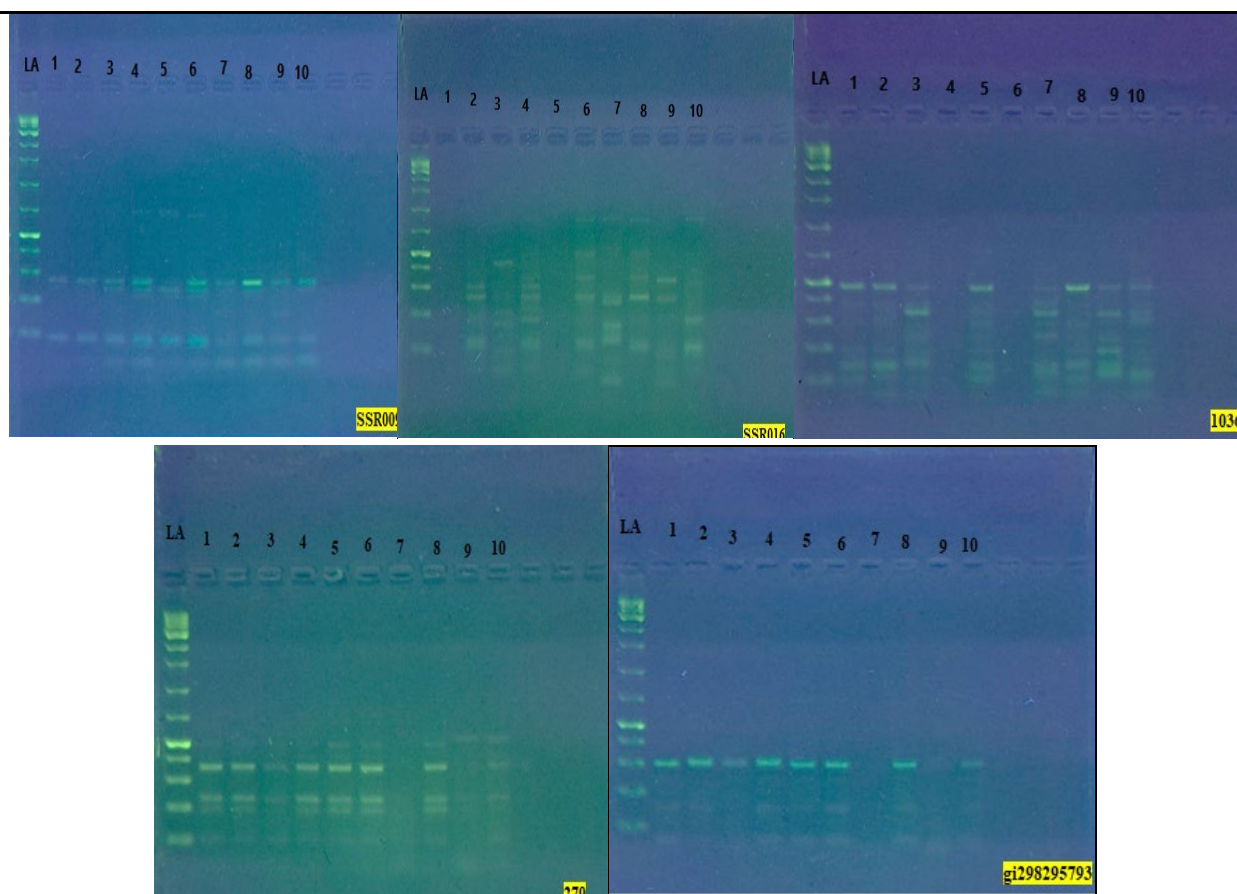

Fig (4) The PCR- SSR primers electrophoresis on a 2% agarose gel at 5 volts. Cen. for 1 : 30 hour utilizing 1x TBE buffer. A DNA ladder of 1000 base pairs was employed as a molecular weight marker.

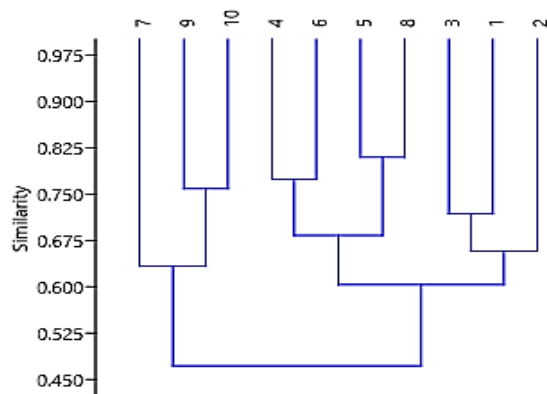

Fig .(5) :A dendrogram illustrating the phylogenetic relationships among ten date palm cultivars was constructed using Nei and Li's similarity coefficient, derived from five SSR primers.

DNA technologies serve as effective instruments for elucidating genetic relationships among various plant cultivars. Simple Sequence Repeat (SSR) markers, recognized for their prevalence and unambiguous outcomes, are frequently employed in this context. ISS tags for palm trees enable researchers to generate reliable molecular data that facilitates the differentiation of distinct cultivars.(Billotte *et al.*, 2004). Polymorphism can be attributed to the fact that ssr technology is distinctive in promoting genetic diversity. This process, characterized by repeating single nucleotides side by side, facilitates the appearance of multiple alleles at each genetic locus. Consequently, this results in an increased degree of genetic variation among different cultivars.(Belaj *et al.*, 2003). The study suggests that the differences in genetic analyses are due to differences in DNA sequences. Variations may include several factors including mutations, chromosome location changes, and the transition of genetic elements within the genome (Williams *et al.*, 1990).

Conclusion

An investigation into the genetic diversity of ten date palm cultivars was conducted utilizing molecular markers through ISSR and SSR methodologies. The findings indicated that the molecular markers generated were reliable and reproducible for assessing genetic diversity among various date palm cultivars. In summary, these techniques prove to be effective in identifying genetic polymorphism within date palm cultivars. The varying responses of these cultivars to in vitro propagation are influenced by their specific genotypes. This knowledge can be leveraged to enhance the effectiveness of date palm breeding initiatives and create new cultivars more appropriately adapted to particular environmental conditions and market demands. The study concluded that cultivars propagated through plant tissue culture did not show significant genetic variation among themselves and with the plant cultivars, especially with the famous cultivar that enjoys the best economic value among the cultivars (Barhi). Therefore, this method can be adopted as one of the safest and most productive methods for propagating palm trees.

Acknowledgments

We extend our gratitude to the Department of Horticulture and Landscape at the College of Agriculture, University of Basrah and Wahj Al-DNA Company for Qualification and Training/ Department of Molecular Biology/ Baghdad /Iraq for offering facilities that supported this research.

Contributions of authors

A.A.S., The proposal for the research.

O.N.J., Developing the experimental methodology.

A.A, M., Conducting research and drafting the manuscript

ORCIDA.A.S., <https://orcid.org/0000-0002-3824-3097>O.N.J., <https://orcid.org/0000-0003-4514-1950>**Conflicts of Interest**

The authors declare no conflicts of interest.

References

- Al-Hamoud, F. M., Abd, A. M., & Ati, M. A. (2023). Analyzing Phytohormone Levels in Fruits of Date Palm *Phoenix dactylifera* L. Derived from Tissue Culture under Different Pollination Treatments. *Basrah Journal of Agricultural Sciences*, 36(2), 256–266. <https://doi.org/10.37077/25200860.2023.36.2.20>
- Al-Khalifah, N. S., & Askari, E. (2003). Molecular phylogeny of date palm (*Phoenix dactylifera* L.) cultivars from Saudi Arabia by DNA fingerprinting. *Theoretical and Applied Genetics*, 107(7), 1266–1270. <https://doi.org/10.1007/s00122-003-1369-y>
- Al-Khayri, J. M., & Ibraheem, Y. (2014). In vitro selection of abiotic stress tolerant date palm (*Phoenix dactylifera* L.): A review. *Emirates Journal of Food and Agriculture*, 26(11), 921–933. <https://doi.org/10.9755/ejfa.v26i11.18975>
- Al-Qatrani, M. K. J., Al Khalifa, A. A. S., & Obaid, N. A. (2021). Effect of Jasmonic Acid on Stimulating the Growth and Development of Date Palm Callus (*Phoenix Dactylifera* L.) Cultivar Shukar in Vitro under Salt Stress Conditions. *IOP Conference Series: Earth and Environmental Science*, 923(1), 1–13. <https://doi.org/10.1088/1755-1315/923/1/012017>
- Al-Qatrani, M. K. J., Khalifa, A. A. S. A., & Obaid, N. A. (2023). In vitro response of shoots multiplications of date palm *Phoenix dactylifera* L. Cv Shakar to Jasmonic acid application under salinity stress. *AIP Conference Proceedings*, 2475, 1–16. <https://doi.org/10.1063/5.0103154>
- Al Khazraji, H. A. K., Abd, A. M., & Abdulla, A. A. (2021). The determination of the genetic distance of various snake melon cucumis melo var. Flexuosus cultivars using inter simple sequence repeat technique (issr). *Basrah Journal of Agricultural Sciences*, 34(1), 111–123. <https://doi.org/10.37077/25200860.2021.34.1.10>
- Alrazn, S. M. H., Alkhalifa, A. A. S., & Al-Sereh, E. A. (2023). Effect of cytokinin TDZ and auxin IBA on the succession of plants of the banana plant *Musaa acumanata*, the Grand-Nain hybrid cultivar, using tissue culture technology. *Journal of Wildlife and Biodiversity*, 7(Special Issue), 277–290. <https://doi.org/10.5281/zenodo.10213198>
- Atienzar, F. A., Conradi, M., Evenden, A. J., Jha, A. N., & Depledge, M. H. (1999). Qualitative assessment of genotoxicity using random amplified polymorphic DNA: Comparison of genomic template stability with key fitness parameters in *Daphnia magna* exposed to benzo[a]pyrene . *Environmental Toxicology and Chemistry*, 18(10), 2275–2282. <https://doi.org/10.1002/etc.5620181023>
- Begna, T., & Yesuf, H. (2021). Genetic mapping in crop plants. *Open Journal of Plant Science*, 6(1), 019–026. <https://doi.org/DOI:https://dx.doi.org/10.17352/ojps.000028>
- Belaj, A., Satovic, Z., Cipriani, G., Baldoni, L., Testolin, R., Rallo, L., & Trujillo, I. (2003). Comparative study of the discriminating capacity of RAPD, AFLP and SSR markers and of their effectiveness in establishing genetic relationships in olive. *Theoretical and Applied Genetics*, 107(4), 736–744. <https://doi.org/10.1007/s00122-003-1301-5>
- Bhattacharai, K., Sharma, S., Verma, S., Peres, N. A., Xiao, S., Clark, D. G., & Deng, Z. (2023). Construction of a genome-wide genetic linkage map and identification of quantitative trait loci for powdery mildew resistance in Gerbera daisy. *Front. Plant Sci.*, 13(1072717), 1–12. <https://doi.org/10.3389/fpls.2022.1072717>
- Billotte, N., Marseillac, N., Brottier, P., Noyer, J. L., Jacquemoud-Collet, J. P., Moreau, C., Couvreur, T., Chevallier, M. H., Pintaud, J. C., & Risterucci, A. M. (2004). Nuclear microsatellite markers for the date palm (*Phoenix dactylifera* L.): Characterization and utility across the genus Phoenix and in other palm genera. *Molecular Ecology Notes*, 4(2), 256–258. <https://doi.org/10.1111/j.1471-8286.2004.00634.x>
- Cerasela, P., A., L., Irina, P., Maria, I.-B. O., Giancarla, V., & C, B. (2011). Somaclonal variation at the nucleotide sequence level revealed by RAPD and ISSR markers. *Journal of Horticulture, Forestry and Biotechnology*, 15(4), 119–123.
- El-Kosary, S., Hmam, I., Gadalla, E. G., & Qenawy, Y. G. (2023). Morphological, Physicochemical, and Molecular Evaluation of Twenty-Three Date Palm

- Males Growing in Aswan Governorate. *Basrah Journal of Agricultural Sciences*, 36(1), 90–106. <https://doi.org/10.37077/25200860.2023.36.1.08>
- El Kadri, N., Mimouna, M. Ben, & Hormaza, J. I. (2019). Genetic diversity of Tunisian male date palm (*Phoenix dactylifera* L.) genotypes using morphological descriptors and molecular markers. *Scientia Horticulturae*, 253, 24–34. <https://doi.org/10.1016/j.scienta.2019.04.026>
- Feng, S., He, R., Lu, J., Jiang, M., Shen, X., Jiang, Y., Wang, Z., & Wang, H. (2016). Development of SSR markers and assessment of genetic diversity in medicinal *Chrysanthemum morifolium* cultivars. *Frontiers in Genetics*, 7(JUN), 1–11. <https://doi.org/10.3389/fgene.2016.00113>
- Ibrahim, A. M., Hameed, M. K., & Mohammed, A. (2023). In Vitro Propagation of Date Palm (*Phoenix dactylifera* L.) Cultivar Jawzi Using Shoot Tip. *Basrah Journal of Agricultural Sciences*, 36(2), 267–284. <https://doi.org/10.37077/25200860.2023.36.2.21>
- Ibrahimi, M., Brhadda, N., Ziri, R., Fokar, M., Amghar, I., Gaboun, F., Habach, A., Meziani, R., Elfadile, J., Abdelwahd, R., & Diria, G. (2024). Molecular Identification of Genetic Diversity and Population Structure in Moroccan Male Date Palm (*Phoenix dactylifera* L.) Using Inter-Simple Sequence Repeat, Direct Amplification of Minisatellite DNA, and Simple Sequence Repeat Markers. *Horticulturae*, 10(5), 1–19. <https://doi.org/10.3390/horticulturae10050508>
- Kadri, K., Hamza, H., Tiba, H., & Elsafy, M. (2022). The Genetic Diversity Analysis of Tunisian Male Date Palm Cultivars (*Phoenix dactylifera* L.) Revealed by Phenotypic and Molecular Markers. *European Journal of Biology and Biotechnology*, 3(5), 6–16. <https://doi.org/10.24018/ejbio.2022.3.5.386>
- Khoulassa, S., Khurshid, H., Fokar, M., Elidriissy, H., Outeha, Y., Elfadil, J., Essarioui, A., Benlyas, M., Mentag, R., & Elmoualij, B. (2023). Genetic diversity of Moroccan date palm revealed by microsatellite markers. *Genetics and Molecular Biology*, 46(2), 1–8. <https://doi.org/10.1590/1678-4685-GMB-2022-0021>
- Kumar, K. R., Cowley, M. J., & Davis, R. L. (2019). Next-Generation Sequencing and Emerging Technologies. *Seminars in Thrombosis and Hemostasis*, 45(7/2019), 661–673. <https://doi.org/10.1055/s-0044-1786397>
- Ngezahayo, F., Dong, Y., & Liu, B. (2007). Somaclonal variation at the nucleotide sequence level in rice (*Oryza sativa* L.) as revealed by RAPD and ISSR markers, and by pairwise sequence analysis. *Journal of Applied Genetics*, 48(4), 329–336. <https://doi.org/10.1007/BF03195229>
- Otu, H. H., & Sayood, K. (2003). A new sequence distance measure for phylogenetic tree construction. *Bioinformatics*, 19(16), 2122–2130. <https://doi.org/10.1093/bioinformatics/btg295>
- Rhouma, S., Zehdi-Azouzi, S., Salem, A. O. M., Rhouma, A., Marrakchi, M., & Trifi, M. (2007). Genetic diversity in ecotypes of Tunisian date-palm (*Phoenix dactylifera* L.) assessed by AFLP markers. *Journal of Horticultural Science and Biotechnology*, 82(6), 929–933. <https://doi.org/10.1080/14620316.2007.11512328>
- Sabir, J. S. M., Abo-Aba, S., Bafeel, S., Zari, T. A., Edris, S., Shokry, A. M., Atef, A., Gadalla, N. O., Ramadan, A. M., Al-Kordy, M. A., El-Domyati, F. M., Jansen, R. K., & Bahieldin, A. (2014). Characterization of ten date palm (*Phoenix dactylifera* L.) cultivars from Saudi Arabia using AFLP and ISSR markers. *Comptes Rendus - Biologies*, 337(1), 6–18. <https://doi.org/10.1016/j.crv.2013.11.003>
- Salah, A. G., Aqeel, A. S., & Khairullah, M. A. (2024). Changes in amino acid levels and their effects on parthenocarpic fruit formation in young Barhi date palms *Phoenix dactylifera* L. derived from tissue culture. *Plant Science Today*, 11(3), 520–526. <https://doi.org/10.14719/pst.3982>
- Suhim, A. A., Awad, K. M., Jaffer, O. N., & Abass, M. H. (2023). The Impact of Salicylic and Jasmonic Acid in Mitigating Salinity Stress on Date Palm *Phoenix dactylifera* L. Barhi Cv. *Basrah Journal of Agricultural Sciences*, 36(1), 120–130. <https://doi.org/10.37077/25200860.2023.36.1.10>
- Sukumaran, S. (2011). Concentration determination of Nucleic Acids and proteins using the micro-volume Bio-Spec nano spectrophotometer. *Journal of Visualized Experiments*, 48(e2699), 1–6. <https://doi.org/10.3791/2699>
- Williams, J. G. K., Kubelik, A. R., Livak, K. J., Rafalski, J. A., & Tingey, S. V. (1990). DNA polymorphisms

amplified by arbitrary primers are useful as genetic markers. *Nucleic Acids Research*, 18(22), 6531–6535. <https://doi.org/10.1093/nar/18.22.6531>

Zhu, H., Song, P., Koo, D.-H., Guo, L., Li, Y., Sun, S., Weng, Y., & Yang, L. (2016). Genome wide

characterization of simple sequence repeats in watermelon genome and their application in comparative mapping and genetic diversity analysis. *BMC Genomics*, 17:557, 1–17. <https://doi.org/10.1186/s12864-016-2870-4>

تقييم التنوع الجيني باستخدام مؤشرات SSR و ISSR على أصناف نخيل التمر المكثرة بزراعة الأنسجة النباتية والمكثرة خضريا.

الحمزة عبد الزهرة محمد السالم¹ و عقيل عبود سهيم¹ و اسامة نظيم جعفر²

¹قسم البستنة وهندسة الحدائق -كلية الزراعة -جامعة البصرة -العراق

²مركز ابحاث النخيل -جامعة البصرة -العراق

المستخلص: ادى انتشار زراعة نخيل التمر في العراق في السنوات الأخيرة الى دورا مهما في إحياء زراعة نخيل التمر ولدراسة التنوع الجيني لنخيل التمر المنتج من زراعة الأنسجة ومطابقته مع بعض الأصناف الخضرية العراقية، تم استخدام الواسمات الجزيئية (ISSR) و (SSR) . أجريت الدراسة الحالية على عشرة أصناف من نخيل التمر (خمسة أصناف مكثرة بالأنسجة) وهي (البرحي ، والصقعي ، والخلاص ، والزامللي ، والمغربي) ، وخمسة أصناف مكثرة خضريا وهي (البرحي ، والحساوي ، والبريم ، والديري ، والشكر). واستخدمت خمسة بواديء لتقنية ISSR (834, 825, ubc815, ubc842, ubc858) وخمسة بواديء لتقنية SSR (SSR009, SSR016, 1036, 270, GI298295793). تم تحليل النتائج باستخدام معامل جاكارد، ورسم المخطط التجميعي باستخدام طريقة UPGMA method of NTSYS-PC program وأظهرت نتائج ISSR تكون 28 من الحزم متعددة الأشكال و18 من الحزم الاحادية الشكل. تراوحت كفاءة البادئات بين (14.2-25) % ، وتعدد الأشكال (57.1-100) % . باستثناء الباديء 834 ، انخفضت مؤشراتته إلى أدنى مستوى ووصلت إلى (20 % و 17.85 %) على التوالي. أظهرت نتائج SSR تكون 35 حزمة متعدد الأشكال و 34 حزمة أحادي الشكل. تراوحت كفاءة البادئات بين (14.28-100) % ، وتعدد الأشكال (80-100) % . باستثناء مؤشر الباديء GI298295793 ، انخفضت كفاءته إلى 8.57 % . يستنتج من الدراسة أن الأصناف التي تم اكتثارها من خلال زراعة الأنسجة النباتية لم تظهر تباينا وراثيا كبيرا فيما بينها ومع الأصناف النباتية لذلك ، يمكن اعتماد هذه الطريقة في التكاثر الإنتاجي لأشجار النخيل.

الكلمات المفتاحية: نخيل التمر، التنوع الجيني، الواسمات الجزيئية ISSR، SSR، زراعة الأنسجة.