

Voltage Tracking Control of DC- DC Boost Converter Using Fuzzy Neural Network

Waleed Ishaq Hameed¹, Baha Aldeen Sawadi², Ali Muayed Fadhil³

¹Department of Electric, Oil Training Institute, Basrah, Iraq

²Department of Communication Engineering, Iraq University College, Iraq

³Department of Architecture, University of Basra, Iraq

Article Info

Article history:

Received Mar 1, 2018

Revised Aug 23, 2018

Accepted Sep 13, 2018

Keyword:

Boost converter

Fuzzy neural controller

Matlab/simulink

ABSTRACT

This paper deals with voltage tracking control of DC- DC boost converter based on Fuzzy neural network. Maintaining the output voltage of the boost converter in some applications are very important, especially for sudden change in the load or disturbance in the input voltage. Traditional control methods usually have some disadvantages in eliminating these disturbances, as the speed of response to these changes is slow and thus affect the regularity of the output voltage of the converter. The strategy is to sense the output voltage across the load and compare it with the reference voltage to ensure that it follows the required reference voltages. In this research, fuzzy neural was introduced to achieve the purpose of voltage tracking by training the parameter of controller based on previous data. These data sets are the sensing input voltage of the converter and the value of the output load changes. To establish the performance of proposed method, MATLAB/SIMULINK environments are presented, simulation results shows that proposed method works more precisely, faster in response and elimination the disturbances.

Copyright © 2018 Institute of Advanced Engineering and Science.
All rights reserved.

Corresponding Author:

Waleed Ishaq Hameed,
Departement of Electrical Engineering,
Oil Training Institute,
Basrah, Iraq.
Email: waleed_ishaq5@yahoo.com

1. INTRODUCTION

Nowadays, DC power supplies are widely utilized in many areas compromising of simple electronic devices such as notebook computers, till even more advance application such as electric vehicle and also the aerospace applications [1]. Hence, the DC- DC converter is usually used by convert a DC voltage to a different DC voltage level in order to provide the DC voltage source level requirements of the load to the DC power supply, In addition, the DC-DC converter is also an important application for the power conditioning of the alternative electrical energy such as photovoltaic, wind generator and fuel cell system. Due to these reasons, the DC-DC converter application will head to a more potential market in the future [2].

Mainly, the DC-DC converter consists of the power semiconductor devices which are operated as electronic switches and classified as switched-mode DC-DC converters or normally refers as Switched mode power supply. To achieve the output voltage constant, feedback control loop is used to automatically adjust the duty cycle regardless of input voltage variation and load changes [3]. Operation of the switching devices causes the naturally nonlinear characteristic of the Boost converters [4]. Due to these unnecessary nonlinear characteristics, the converters require a controller with a high degree of dynamic response [5]. PID controllers undergo from repeated tuning of their parameters for disturbance conditions and different loads [6]. PID controller have some disadvantages such as slow response to the sudden change in the load or disturbance in the input voltage.

One of the design targets for electronic engineers is to improve the efficiency of power conversion. For PWM (pulse-width modulation) converters, switching loss is an important performance measure [7]. The artificial intelligent control, such as Fuzzy logic and neural network are very capable for the identification, adaptive and control for nonlinear dynamical systems [8]. Fuzzy Neural control is an attractive control method because its structure, consisting of fuzzy sets that allow partial membership and “if - then” rules, resembles the way human intuitively approaches a control problem. This makes it easy for a designer to incorporate heuristic knowledge of a system into the controller. Fuzzy Neural control is obviously a great value for problems where the system is difficult to model due to complexity, non-linearity, and imprecision. DC-DC boost converters fall into this category because they have a time-varying structure and contain elements that are non-linear and have parasitic components [9]. The artificial intelligent control such as Fuzzy Neural is fast in elimination the disturbances.

In this paper, MATLAB Simulink is used as a platform in designing the DC- DC boost converter and Fuzzy Neural Network (FNN) controller in order to study the dynamic behavior of dc to dc converter and performance of proposed controller.

2. DC-DC BOOST CONVERTER

The function of boost converter is to serves as step up voltage from one level to another level [10]. The circuit of DC-DC boost converter is shown in Figure 1.

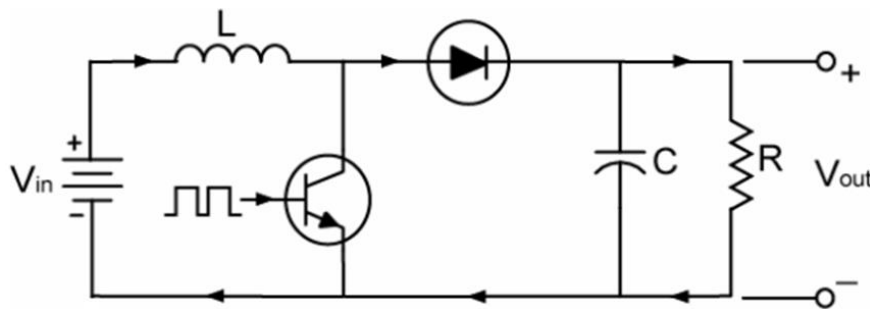

Figure 1. DC-DC Boost Converter circuit [11]

The equations design of Loss boost converter in CCM can be written as following [12]. The input to output voltage conversion ratio is obtained as:

$$V_o = \frac{V_i}{1-D} \quad (1)$$

The duty ratio of the loss boost converter is

$$D = 1 - \frac{\eta}{M_{DC}} = 1 - \frac{\eta V_i}{V_o} \quad (2)$$

where η is the efficiency of the converter and M_{DC} is the voltage transferal functions. The minimum and the maximum load resistances are

$$R_{min} = \frac{V_o}{I_{Omax}} \quad (3)$$

and

$$R_{max} = \frac{V_o}{I_{Omin}} \quad (4)$$

The minimum, nominal, and maximum values of the voltage transferal function are

$$M_{DCmin} = \frac{V_o}{V_{imax}} \quad (5)$$

$$M_{DCnom} = \frac{V_o}{V_{i\ nom}} \tag{6}$$

and

$$M_{DCmax} = \frac{V_o}{V_{i\ min}} \tag{7}$$

$$D_{min} = 1 - \frac{\eta}{M_{DCmin}} \tag{8}$$

$$D_{nom} = 1 - \frac{\eta}{M_{DCnom}} \tag{9}$$

3. FUZZY NEURAL NETWORKS

A favorable approach to obtaining the benefits of both fuzzy and neural network systems is to integrates both neural networks and fuzzy logic principles [13]. The integrated system will take the advantages of learning abilities, optimization abilities, and connectionist structures (in neural network) with IF-THEN humanlike rules thinking and ease of combining expert knowledge). Fuzzy neural networks (FNN) explain fuzzy parameter from given training data. This is usually done by using membership functions with a neural network. The structural design of FNN shown in Figure 2. In the following substances each layer will be defined [14]. Input Layer: this layer transmits the crisp variables x_n to the output without changed. Hidden Layer: this layer represents the input crisp values with the following Gaussian functions:

$$\mu_j^i = \exp\left(-\frac{1}{2} \frac{(x_j - c_{ij})^2}{s_{ij}^2}\right) \tag{10}$$

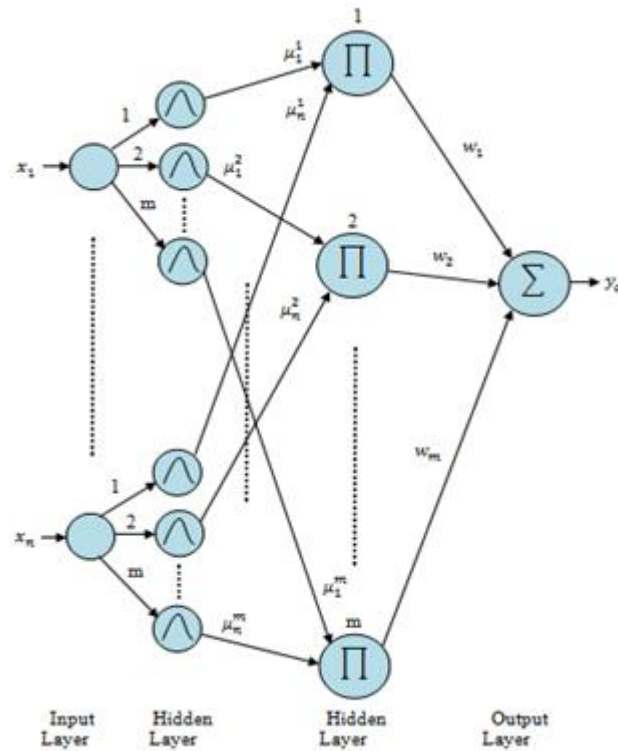

Figure 2. Architecture of FNN

Where c_{ij} and s_{ij} ($i=1, 2, \dots, n$; $j=1, 2, \dots, m$), are the mean and standard deviation of the Gaussian function respectively in the j^{th} term of the i^{th} input linguistic variable x_j to the node of this layer. Hidden Layer: this layer implements the fuzzy inference mechanism. The output of this layer is given as:

$$\phi_i = \prod_j^n \mu_j^i \tag{11}$$

where ϕ_i represent the i^{th} output of rule layer. Output Layer: this layer represents output linguistic variables. This computes the output as:

$$y_o = \sum_i^m w_i^o \phi_i \tag{12}$$

where w_i^o denote the i^{th} output weight.

4. DESIGN OF VOLTAGE TRACKING CONTROL

The block diagram of voltage tracking control is shown in Figure 3.

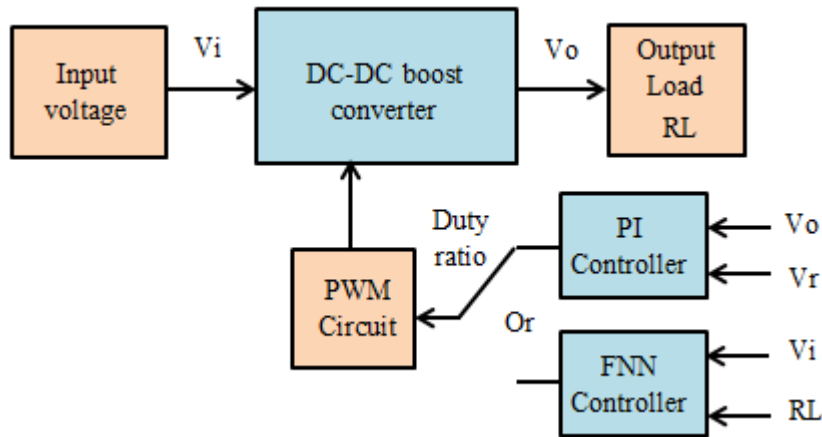

Figure 3. Block diagram of voltage tracking control

Figure 4 shows the Matlab/Simulink of DC-DC boost converter with PI controller.

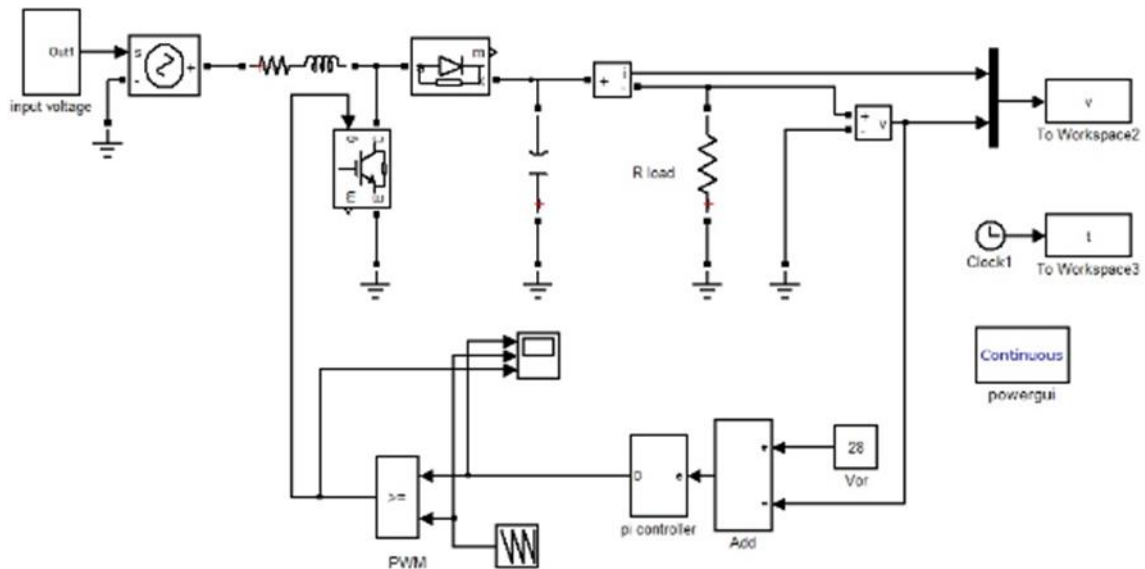

Figure 4. Simulink implementation of PWM Boost Converter based on PI controller

Based on above mentioned design equations, PWM Boost Converter had been designed to meet the following specifications: $V_i=14$ v, $V_O = 28$ V, $I_{Omax} = 14$ A, $I_{Omin} = 3.5$ A, and $V_r /V_O < 1\%$. Assume that boost converter operate in CCM and the duty ratio varies from 0.4 to 0.75.

Figure 5 shows the developed model system with fuzzy-neural controller. The parameters of the fuzzy-neural controller (member ship functions and output weights) had been training off-line using m-file and then the optimal values fed to the fuzzy-neural controller block model as shows in Figure 6 and 7 respectively. In the prime’s part, the number of membership functions for each input is three. So, the number of weights in the consequence output part is also three. The first input to FNN is the measured output load RL while DC input supply voltage to the converter V_i is the second input to the FNN.

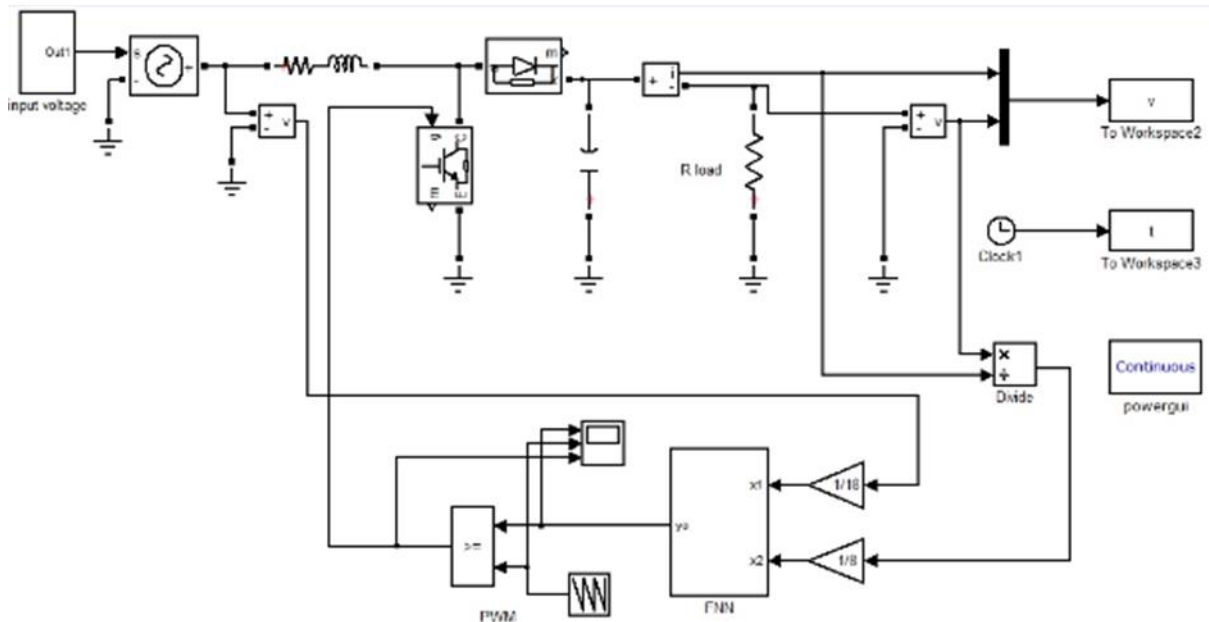

Figure 5. Simulink implementation of PWM Boost Converter based on FNN controller

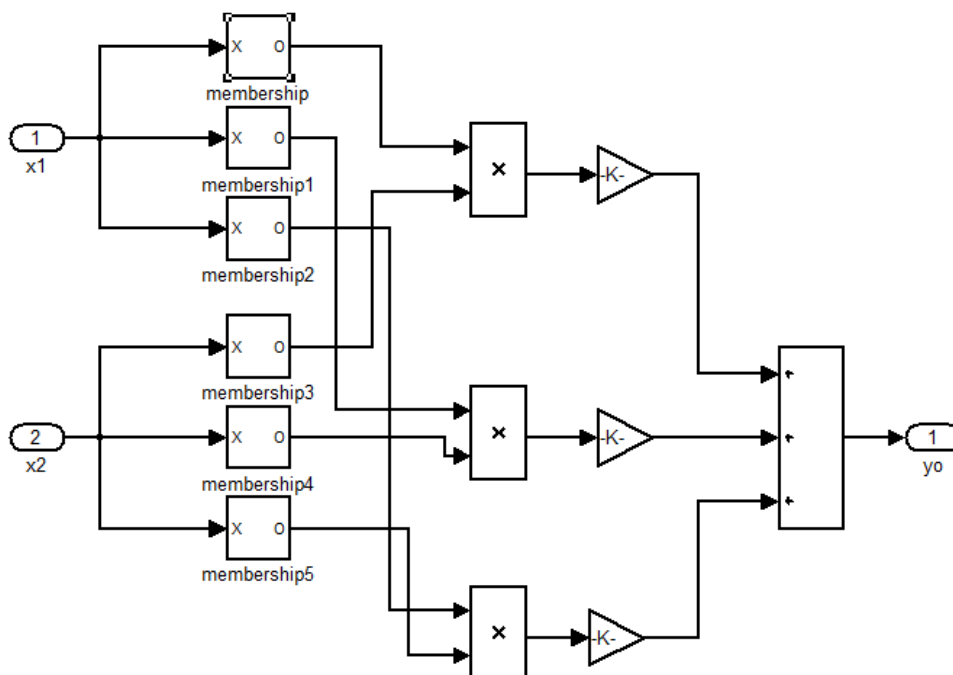

Figure 6. Simulink implementation of FNN controller

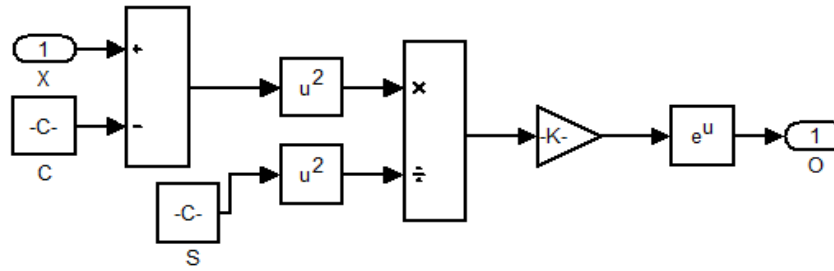

Figure 7 Simulink implementation of membership functions

5. SIMULATION RESULTS

Figure 8 and 9 shows the parameter of FFN controller before and after training. As shown in these figures, the number of training ends in about 150 iterations.

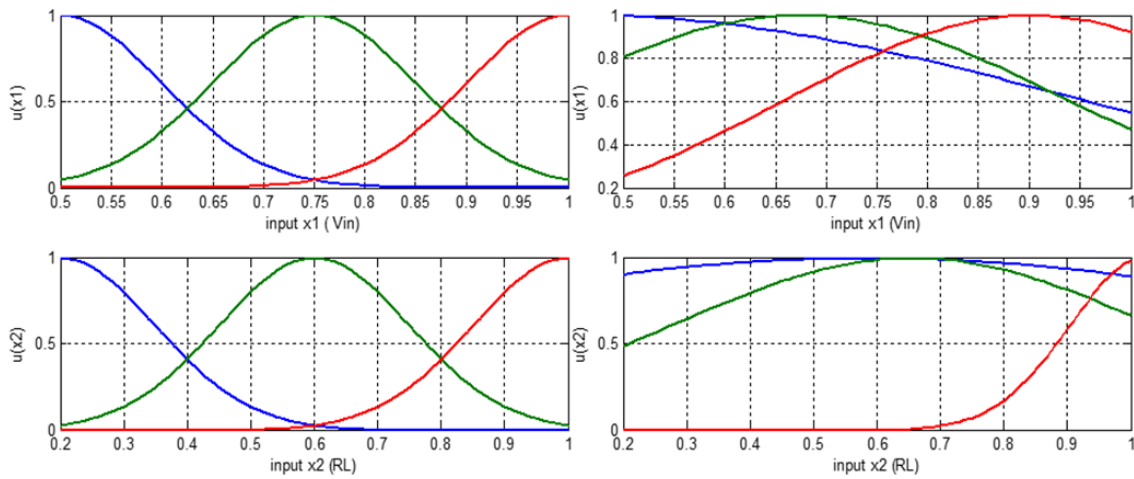

Figure 8. Membership functions parameter before and after training

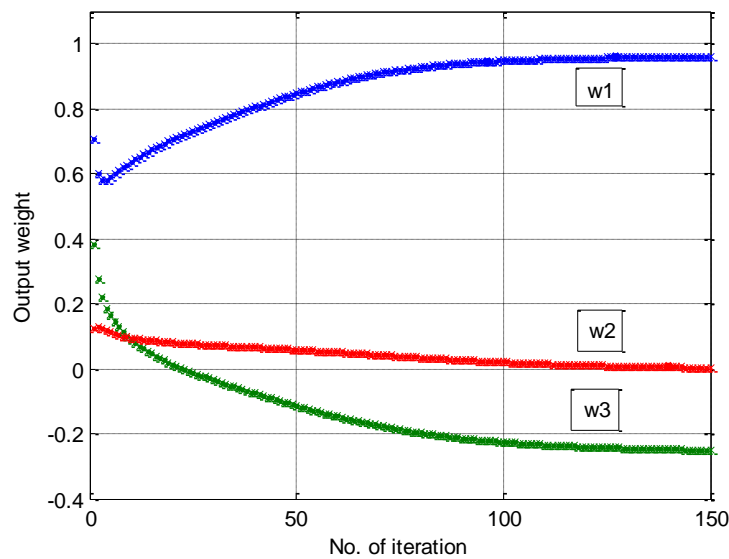

Figure 9. Output weights during training

Figure 10 show a step change in RL from 2 to 8 and then to 4 at fixed $V_i = 14$ v for both pi and FNN controller.

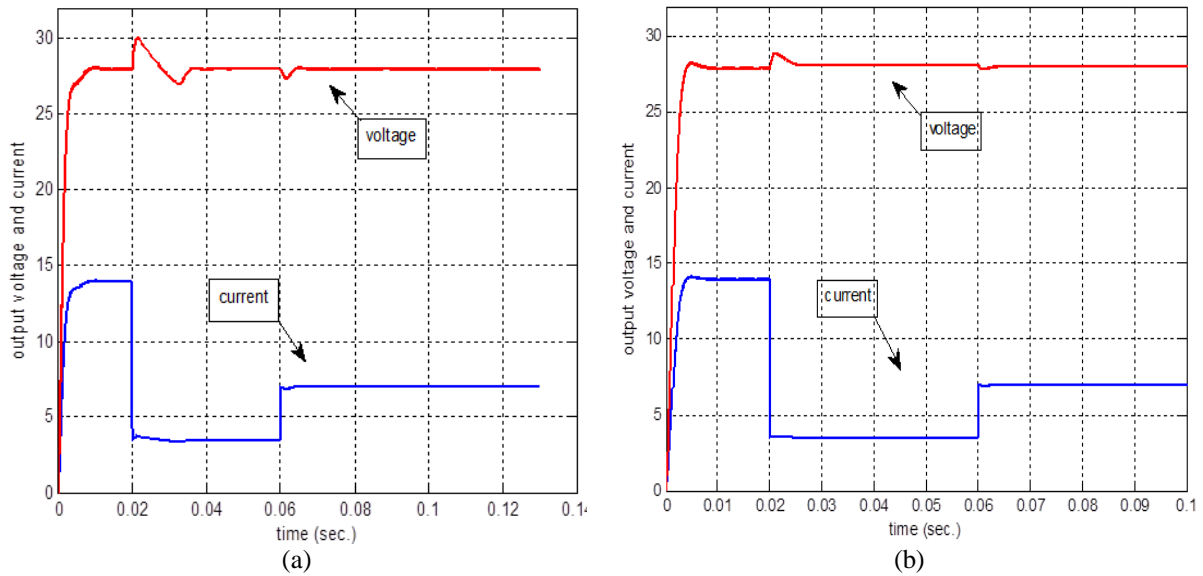

Figure 10. The output of converter when a step changes in RL: (a) with PI controller; (b) with FNN controller

As shown in figures above, the FNN controller is faster in response than PID and more precisely in elimination the overshoot when large step change in the output load. In other words, FNN controller Maintaining the output voltage regardless of the disturbances.

Several changes have been applied to the input voltage V_i as followings: A step change in V_i (from 14 v to 18 v) when $RL = 4 \Omega$ was applied at $t=0.02$ sec, back to 14 v at $t=0.02$ sec and then decrease to 10 v at $t=0.06$ sec the output voltage response for both pi and FNN controller are shown in Figure 11. Same procedures as mentioned also applied when $RL = 7 \Omega$. The output response for these changes in input voltage is shown in Figure 12.

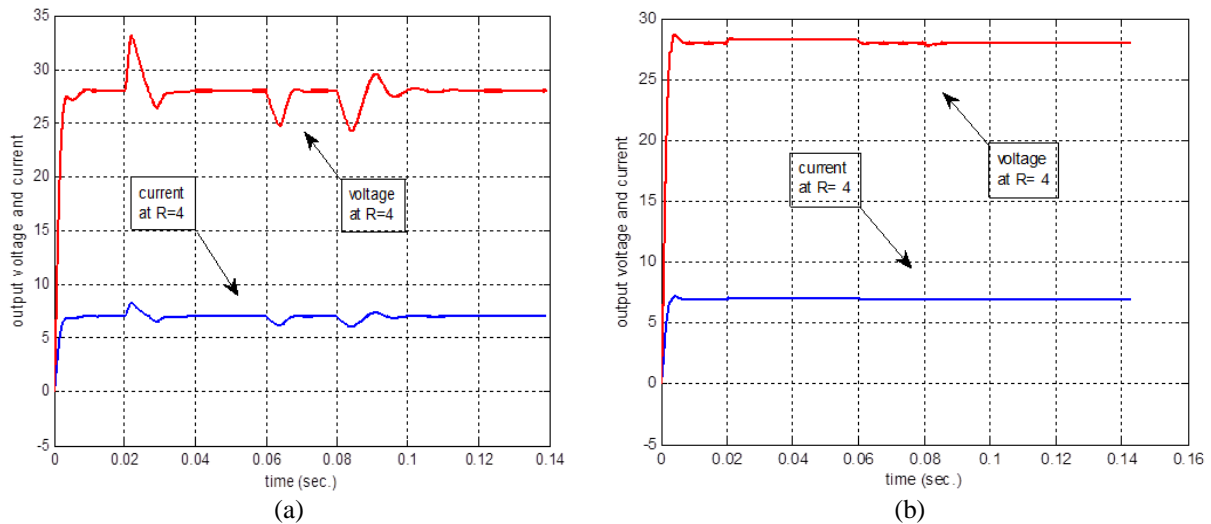

Figure 11. The output of the converter when a step change in V_i at fixed $RL = 4 \Omega$: (a) with PI controller; (b) with FNN controller

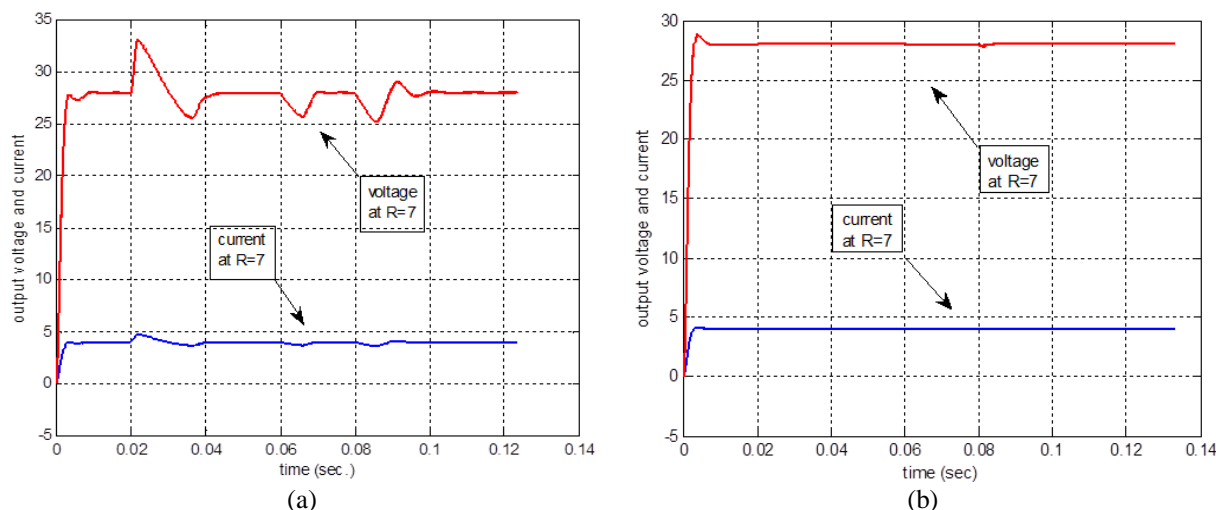

Figure 12. The output of the converter when a step change in V_i at fixed $RL\ 7\ \Omega$: (a) with PI controller; (b) With FNN controller

The comparison between the results above show that FNN controller is better than PID controller because the output voltage of the boost converter is regulating at reference voltage and kept constant for any step change in the input voltage.

6. CONCLUSION

Output voltage tracking of DC-DC boost converter by using fuzzy neural controller is investigated. The converters assume to operate in CCM with 90% efficiency. Pre-data sets are presented by sensing both changes in the input voltage supply to the converter and the output load. these data sets used to training the parameter of the controller off-line. Dependent on the input values, the controller will produce the suitable duty ratio to the converter to ensure the output voltage tracking the desired voltage. Comparison between PI controller and FNN controller as shown in the simulation results demonstrated the effectiveness of the proposed technique in maintaining the stability of the output voltage and in reducing the disturbances with fast eliminating.

REFERENCES

- [1] L. Yin, *et al.*, "DSP based Control of Parallel DC-DC Boost Converters by Adaptive Fuzzy Sliding-Mode Control Scheme," *IEEE Fourth International Conference on Genetic and Evolutionary Computing (ICGEC)*, pp. 130-133, 2010.
- [2] J. D. Navamani, *et al.*, "Analysis of modified quadratic DC-DC boost converter," *IEEE International Conference on Inventive Systems and Control (ICISC)*, pp. 1-5, 2017.
- [3] O. Ibrahim and N. Z. Yahaya, "PID Controller Response to Set-Point Change in DC-DC Converter Control," *International Journal of Power Electronics and Drive System (IJPEDS)*, vol/issue: 7(2), 2016.
- [4] A. Ali, *et al.*, "Implementation of simple moving voltage average technique with direct control incremental conductance method to optimize the efficiency of DC microgrid," *IEEE International Conference Emerging Technologies (ICET)*, pp. 1-5, 2015.
- [5] M. Khayamy, *et al.*, "Adaptive Fuzzy Logic Control Mixing Strategy of DC/DC Converters in Both Discontinuous and Continuous Conduction Modes," *Journal of Control, Automation and Electrical Systems*, vol/issue: 27(3), pp. 274-288, 2016.
- [6] P. V. R. Kumar and M. S. Kalavathi, "Fractional Order PID Controlled Interleaved Boost converter Fed Shunt Active Filter System," *International Journal of Power Electronics and Drive System*, vol/issue: 9(1), 2018.
- [7] M. Zainuri, *et al.*, "Development of adaptive perturb and observe-fuzzy control maximum power point tracking for photovoltaic boost dc-dc converter," *IET Renewable Power Generation*, vol/issue: 8(2), pp. 183-194, 2014.
- [8] Saidah, *et al.*, "Control Strategy for PWM Voltage Source Converter Using Fuzzy Logic for Adjustable Speed DC Motor," *International Journal of Power Electronics and Drive System*, vol/issue: 8(1), 2017.
- [9] R. Wai, *et al.*, "Design of Adaptive Control and Fuzzy Neural Network Control for Single-Stage Boost Inverter," *IEEE Transactions on Industrial Electronics*, vol/issue: 62(9), pp. 5434-5445, 2015.
- [10] Budiyanto and R. Setiabudy, "Inverter Development as A Boost Converter for DC Microgrid," *TELKOMNIKA Telecommunication Computing Electronics and Control*, vol/issue: 11(2), 2013.

- [11] M. Ferchichi, *et al.*, "Comparative analysis for various control strategies based MPPT technique of photovoltaic system using DC-DC boost converter," *IEEE 17th International Conference Sciences and Techniques of Automatic Control and Computer Engineering (STA)*, pp. 532-539, 2016.
- [12] M. K. Kazimierczuk, "Pulse-width Modulated DC-DC Power Converters," John Wiley & Sons, USA, 2008.
- [13] A. B. Muljono and I. M. Ginarsa, "Coordination of Adaptive Neuro Fuzzy Inference System (ANFIS) and Type-2 Fuzzy Logic System-Power System Stabilizer (T2FLS-PSS) to Improve a Large-scale Power System Stability," *International Journal of Electrical and Computer Engineering (IJECE)*, vol/issue: 8(1), 2018.
- [14] W. I. Hameed and K. A. Mohamad, "Strip Thickness Control of Cold Rolling Mill with Roll Eccentricity Compensation by Using Fuzzy Neural Network," *Engineering*, vol/issue: 6(1), pp. 27-33, 2014.

BIOGRAPHIES OF AUTHORS



Waleed Ishaq Hameed M.Sc in Electrical Engineering, Faculty of Engineering, Basra University in 2013. I am working a teacher, Supervisor of Instrumentation and Control Laboratory in Basra Oil Training Institute 2016-yet. In general I have theoretical and practical experience in the following fields: • Renewable energy • Motor Speed control and drive • Motion control • Adaptive control • Artificial Intelligence • Machine learning • Process control and instrumentation • Fuzzy-Neural control • Wireless sensor network and IoT • Programmable logic controller and Microcontrollers.



Baha Aldeen Sawadi M.Sc in Electrical- electronic and telecommunication from University technology Malaysia UTM in 2009.



Ali Muayed Fadhil B.SC in computer engineering from University of Basra,Iraq, in 2007 and his M.SC degree in computer and electrical engineering from Basra University in 2013. He was a researcher at college of engineering, university of Basra during 2013-2015, He is a Lecture at department of architecture, college of engineering from 2015 to present. His Research interest include computer networking, wireless sensor networks, control system, DC motor, routing, robotics, telecommunication, microcontroller such as Arduino, and information technology, internet of things.