

Comparison the Hydraulic Harvested Energy with the Electromagnetic Systems and the Spent Energy on the Active System

Murtadha Q. Dinar^{1,*}, Haider J. Abid², Hassanein I. Khalaf³

^{1,3} Department of Mechanical Engineering, College of Engineering, University of Basrah, Basrah, Iraq

² Department of Mechanical Engineering, College of Engineering, University of Thi-Qar, Thi-Qar, Iraq

E-mail addresses: pgs2337@uobasrah.edu.iq, haider-jabaur-abid@utq.edu.iq, hassanein.khalaf@uobasrah.edu.iq

Received: 20 November 2021; Accepted: 15 December 2021; Published: 15 April 2022

Abstract

An energy-harvesting hydraulic regeneration suspension system is described in this article, which includes a hydraulic motor, a spool valves, and a hydraulic cylinder. Regenerative actuators are built using a hydraulic transmission system as their inspiration. The proposed regenerative actuator is implemented in the vehicle's non-linear suspension system for a complete model. MATLAB Simulink is utilized to generate and simulate the entire vehicle's regenerative suspension system, which has force properties which are nonlinear with hydraulic actuators equations with energy harvesting from regenerative actuators. During the mathematical simulation, the effect of pressure differential on the spool valve's operation is also taken into account. The quantity of captured energy is compared to the energy expended on the active actuator and the energy generated with the electromagnetic actuator at three distinct input signals at three different pressure level (10,30 and 50 bars) (random, sinusoidal, and square). The energy generated in the regenerative hydraulic actuator at three pressure levels behaves the same as the active actuator in terms of response, plus the highest pressure of 50 bar is closely comparable to the active system in terms of energy harvest and gradually decreases as the output pressure drops in addition to the behavior of the electromagnetic and its comparison with the wasted energy of the active system.

Keywords: Energy harvesting, Regenerative actuator, Active actuator, Electromagnetic actuator

© 2022 The Authors. Published by the University of Basrah. Open-access article.

<http://dx.doi.org/10.33971/bjes.22.1.6>

1. Introduction

It is common for vehicles to be subjected to anomalies, which can lead to instability and discomfort for the driver. As a result of this, suspensions are employed in automobiles to protect drivers and enhance maneuverability. The most common form of suspension system, passive suspension systems are assumed to be made up of springs and shock absorbers with fixed rates of travel. Despite the fact that this passive suspension is affordable and dependable, it has performance limits owing to unforeseen road profiles. Modern automobiles' suspensions now have actuators that automatically modify the damping force in response to road input, resulting in improved performance. The primary disadvantage of this technology is the high-power consumption of the actuator and control unit. Due to the active suspension system's high-power consumption, many vehicle manufacturers and researchers have attempted to develop systems that would harvest energy from vehicle systems in order to supply the active suspension with the necessary power from a source of energy regeneration in recent years [1]-[4].

Many different forms of energy regenerating systems have been developed, including hydraulic storage suspension [5] such as, battery coil induction suspension [6], rack and pinion suspension [7], ball screw suspension [8], and linear

motion suspension [9]. Ansari and Taparria [10] changed a passive suspension system to an active suspension system by Likening the passive parts with a controlled actuator (hydraulic, magneto-rheological, or pneumatic). This research employs a hydraulic actuator as a controlled actuator. The attached actuators' primary job is to add additional forces to the suspension system, which will decrease vibrations caused by bumpy roads. The actuator forces are generated by an intelligent control law that uses data from sensors mounted to the vehicle. Fang et al. [11] have been extracted energy from the suspension system, devised and constructed an electromagnetic shock absorber with hydraulic transmission. The prototype was built using a rectifier to ensure that the hydraulic motor rotates in a single direction, increasing regeneration efficiency. When the prototype was subjected to a 10 Hz frequency and 3 mm amplitude input, bench test findings showed that roughly 200 W could be recovered with a 16 percent efficiency. Liang et al. [12] have been invented a hydraulic energy harvesting mechanism that rectifies bidirectional motion and converts it to unidirectional rotation using four check valves. To evaluate the model empirically, a prototype was built and tested. When the sinusoidal input frequency was 2 Hz and the amplitude was 8 mm, experimental results showed that roughly 115 W mean power could be collected with a 38

percent efficiency. Zuo et al. [13] created a hydraulic regenerative shock absorber's theoretical analysis (HRSA).

A computer simulation was performed using AMESim (Advanced Modeling Environment) on the basis of their theoretical model. Engineering system simulation and hydraulic transmission circuit modeling. Authors [14], [15] expanded their effort to include experimental testing of the prototype and examination of sensitivity to various variables. Zhang et al. [16] new a dual hydraulic harvester that harvests energy from the vehicle's suspension has been developed. Two check valves and a gas chamber ensured unidirectional oil flow and provided the necessary asymmetric damping force in their design. To find the best design parameters, a genetic algorithm optimization was used. Li et al. [17] Assuming a quarter-car model, the mechanical motion rectifier in the regenerative shock absorber produced an average output of 80 watts when moving at 30 mph on a class C road. Guo et al. [18] the power generated from a 2-DOF regenerative suspension with a rack and pinion system was investigated. The simulation was run at different vehicle speeds and on different roads. When the tiny passenger automobile moved at a speed of 97 km/h on the average road, the results showed that roughly 30 W of average electricity could be harvested. Xu et al. [19] a 2-DOF hydraulic regenerative suspension moving at a speed of 20 m/s on an average road generated a maximum gathered power of 200 W.

In this work, Using a control system of the type Fractional Order Proportional Integral Derivative controller(FOPID), a mathematical model of a full car nonlinear regenerative suspension system with hydraulic actuators was developed and modeled. Then, the energy harvesting equation was applied by the piston forces for each actuator in addition to the total energy of the actuators, all modeling for the whole work was done using the MATLAB-Simulink program and applied it theoretically.

2. Hydraulic actuators and the full vehicle suspension system modeled.

As shown in Figs. 1 and 2, the systems consist of a hydraulic cylinder, piston, spool valve, hydraulic motor, and dynamo. A vehicle passing over a bump generates a displacement (u_i) that is transmitted through the suspension system (w_i) and then to the vehicle's body (z_i). The forces transmitted from the bump affect the hydraulic actuator, which leads to the movement of the piston inside the cylinder, which in turn generates a pressure difference, which leads to the hydraulic withdrawal from the tank (P_f), which is usually the same atmospheric pressure. The FOPID control, which will be explained later, will control the spool valve according to the displacement derivative resulting from the bump, and on this basis, the valve will open and close to restrict the hydraulic and pressure. The resulting pressure (P_o) is transmitted to a hydraulic motor to produce a rotational movement that is used to rotate a dynamo, which generates electrical energy in addition, the opposite forces generated by the hydraulic piston due to hydraulic pressure will improve the amount of displacement response with time.

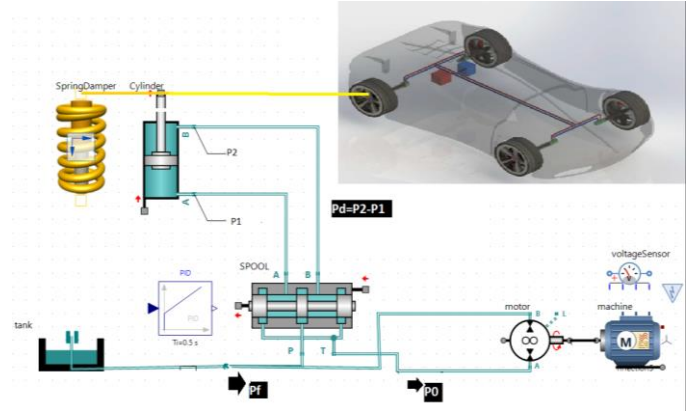

Fig. 1 beams layout and test setup.

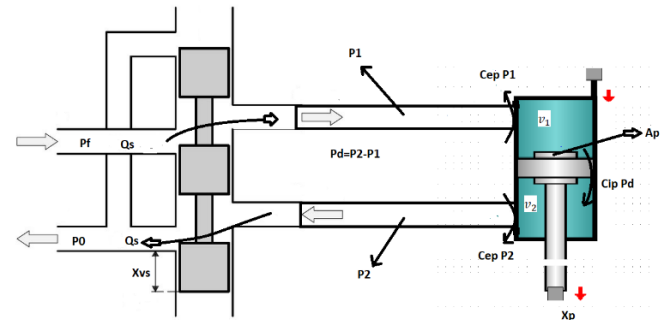

Fig. 2 spool valve with actuator.

The following are the general flow rate formulas for orifices:

$$Q_{Ldi} = C_{dc} \omega x_{svi} \sqrt{\frac{1}{\rho} (P_{fi} - \text{sgn}(x_{svi}) P_{di} - P_{oi})} \quad (1)$$

change in pressures given by:

$$\dot{P}_{di} = -\delta P_{di} - \Psi A_p \dot{x}_{pi} + \Psi Q_{Ldi} \quad (2)$$

The movements of a spool valves (x_{svi}) that regulated by incoming signal (u_{mi}) at a constant time (τ) is

$$\dot{x}_{svi} = \frac{1}{\tau} (u_{mi} - x_{svi}) \quad (3)$$

The following are the hydraulic actuators forces:

$$F_{hyi} = A_p P_{di} \quad (4)$$

Nonlinear force characteristics are found in full vehicle nonlinear regeneration suspension systems with hydraulic actuators.

Motion in the vertical direction:

$$f_{Ksi} = K_{si}(z_i - w_i) + \mu K_{si}(z_i - w_i)^3 \quad (5)$$

$$f_{Ci} = C_i(\dot{z}_i - \dot{w}_i) + \mu C_i(\dot{z}_i - \dot{w}_i)^2 \text{sgn}(\dot{z}_i - \dot{w}_i) \quad (6)$$

$$F_{ai} = F_{hyi} - F_{fri} \quad (7)$$

The motion is rolling.:

$$J_x \ddot{\gamma} = (f_{Ks1} - f_{Ks2} - f_{Ks3} + f_{Ks4}) \frac{b}{2} + (f_{C1} - f_{C2} - f_{C3} + f_{C4}) \frac{b}{2} + (f_{a3} - f_{a1} + f_{a2} - f_{a4}) \frac{b}{2} + T_x \quad (8)$$

The motion is Pitching:

$$J_y \ddot{\beta} = (f_{ks3} + f_{ks4}) l_2 - (f_{ks1} + f_{ks2}) l_1 + (f_{C3} + f_{C4}) l_2 - (f_{C1} + f_{C2}) l_1 + (f_{a1} + f_{a2}) l_1 - (f_{a3} + f_{a4}) l_2 + T_y \quad (9)$$

Unsprung masses' vertical movements equation may be rewritten as:

$$m_i \ddot{w}_i = C_i \dot{z}_c - 0.5 b C_i \dot{\gamma} - C_i l_i \dot{\beta} + \mu C_i (\dot{z}_i - \dot{w}_i)^2 \operatorname{sgn}(\dot{z}_i - \dot{w}_i) - (C_i + c_{ii}) \dot{w}_i + c_{ii} \dot{u}_i + K_{si} z_c - 0.5 b K_{si} \gamma - K_{si} l_e \beta + \mu K_{ii} (z_i - w_i)^3 - (K_{si} + k_{ii}) w_i + k_{ii} u_i - A_p P_{Li} + f_{fri} \quad (11)$$

Where: $e = 1$ for $i = (1, 2)$ and $e = 2$ for $i = (3, 4)$

Note: equations (1)-(11) from [4]

The Energy Harvesting from Regenerative Suspension [20]:

$$P_{regi}(j) = F_{ai}(j) \times \left((\dot{z}_i(j) - \dot{w}_i(j)) - (\dot{z}_i(j-1) - \dot{w}_i(j-1)) \right) \quad (12)$$

The following calculation may be used to calculate the total harvest power of each hydraulic actuator:

$$P_{treg} = \sum_j F_{ai}(j) \times \left((\dot{z}_i(j) - \dot{w}_i(j)) - (\dot{z}_i(j-1) - \dot{w}_i(j-1)) \right) \quad (13)$$

The energy expended on the active system for each corner of the suspension j^{th} system may be computed using the equation below [20]:

$$P_{acti}(j) = F_i(j) \times \left((\dot{z}_i(j) - \dot{w}_i(j)) - (\dot{z}_i(j-1) - \dot{w}_i(j-1)) \right) \quad (14)$$

The following equation may be used to calculate the total consumption power of each hydraulic actuator:

$$P_{tact} = \sum_j F_i(j) \times \left((\dot{z}_i(j) - \dot{w}_i(j)) - (\dot{z}_i(j-1) - \dot{w}_i(j-1)) \right) \quad (15)$$

The electromagnetic DC motor's power may be expressed as [21]:

$$\text{Power of the motor} = \frac{4 \pi \Phi}{P_H} v I \quad (16)$$

3. Suspension System Simulation

The simulation process had been done within MATLAB-Simulink environment by building a block diagram which represent the motion of the systems. Figure 3 represents the system blocks diagram contains active and regenerative, the Fig. 4 represents the electromagnetic subsystems and Fig. 5 represents the passive subsystem. The contents of subsystem of full vehicle regenerative suspension system shown in Fig. 6.

4. Results and Discussions

The harvesting energy of the vehicle suspension system (regenerative and electromagnetic actuators) and consuming power for active actuators were investigated using simulations (MATLAB Simulink software) for vertical displacement at each corner and overall power consumption. The simulation was performed for three cases of signal input waves (random, sinusoidal and square) at amplitude 10 mm and frequency 0.1 Hz with consideration three level of hydraulic pressures (10, 30 and 50) bar as working fluid in the system.

4.1. Random Wave for Active, Electromagnetic and Regenerative System

Measurement of the values of the power harvested and consumed during a time of 10 seconds and amplitude of 1 cm during random wave for active system, electromagnetic system and regenerative system (10, 30, and 50 bars).

The comparison of the energy generated between the regenerative system and the electromagnetic system and consumed in the active system in random wave.

Figures 7-10 shown a close match between the behavior of the active system in terms of energy consumption and the regenerative system in terms of power generation which gradually decreases as the outlet pressure decreases P_o from which the pressure difference can be determined as mentioned in eq. (2). This reason is attributed to the force that the hydraulic actuator produces F_{ai} . The total energy of each system has an amount of 30.6 kW consumption for active system because this system uses electrical energy to rotate a hydraulic pump to pump the hydraulics into the cylinder, which in turn reduces the force transmitted to the vehicle body, and the harvesting energy 28.7, 27.9 and 26.6 kW for regenerative at (50, 30 and 10 bars) respectively at ten second where the value of the output pressure can be controlled by the displacements of the spool valves (x_{svi}) as mentioned in eq. (3) and controlled by (FIPID) controller. The electromagnetic system shows the behavior of energy harvesting by the rack and pinion system, so we note a different behavior of energy harvest compared to the rest of the aforementioned systems, and the total has an amount of -7.16 kW at ten second this power is produced by the system's DC motors and the sign is only negative to sort the illustration to show the work of each system.

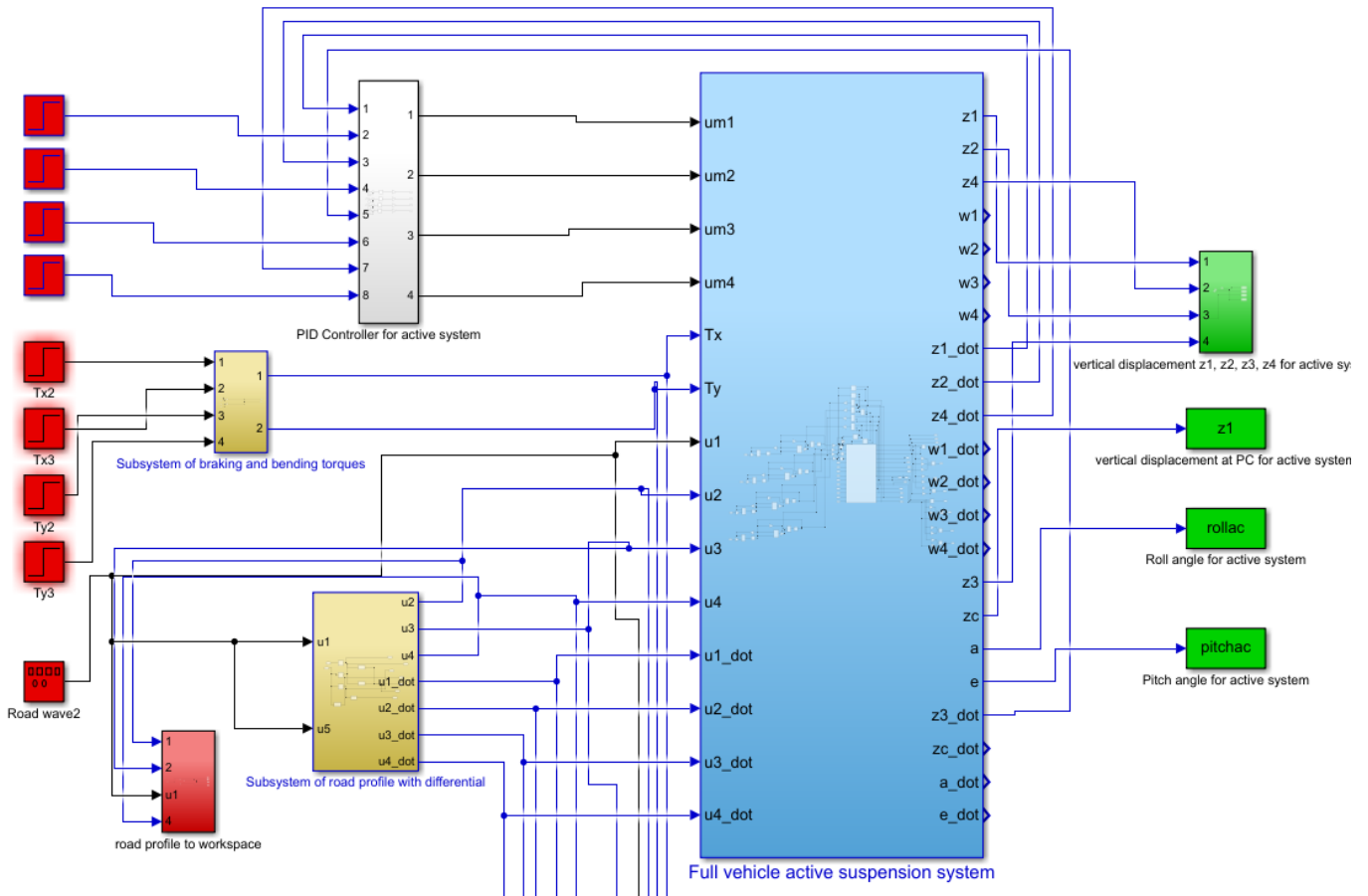

Fig. 3 Full-vehicle active and regenerative suspension systems block diagram.

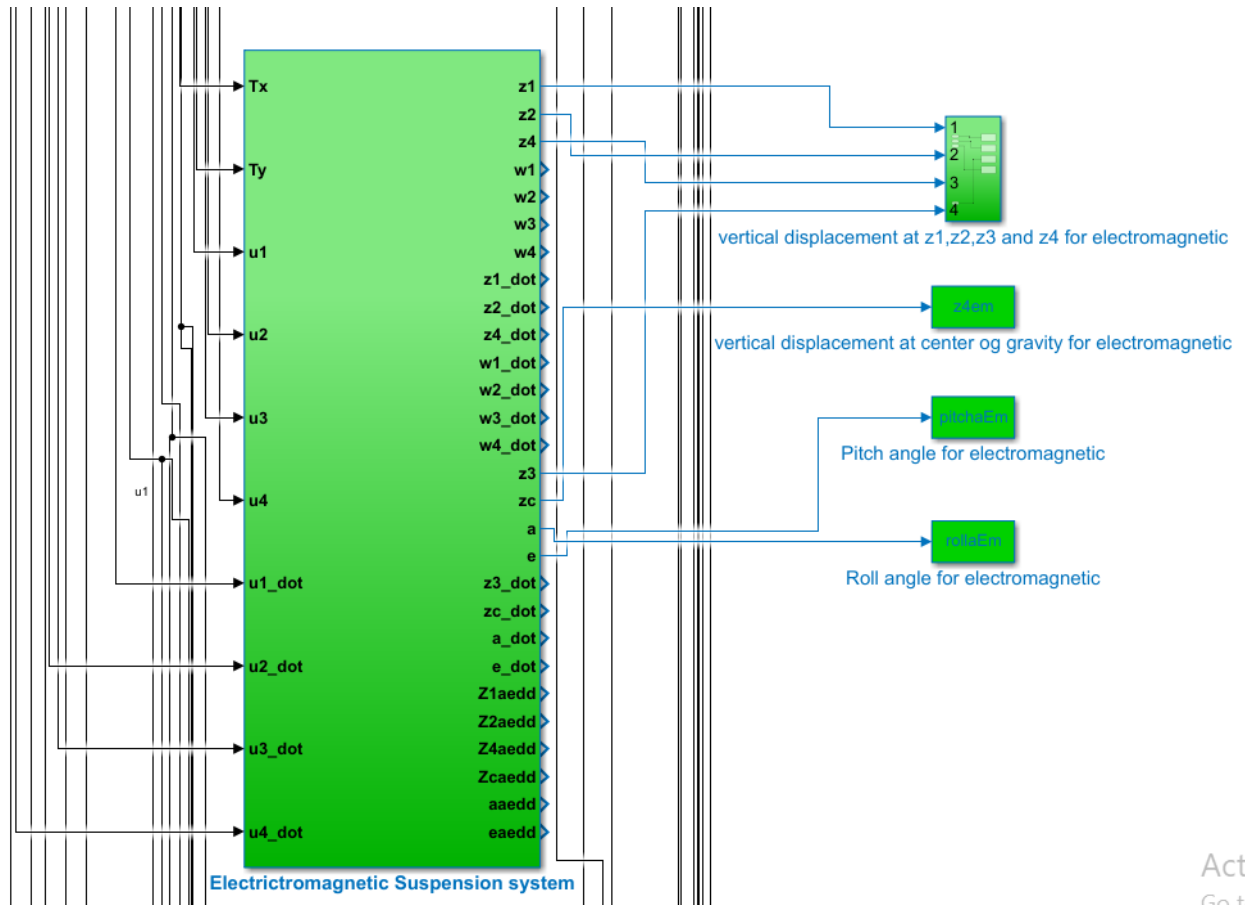

Fig. 4 Full vehicle electromagnetic suspension systems main block diagram.

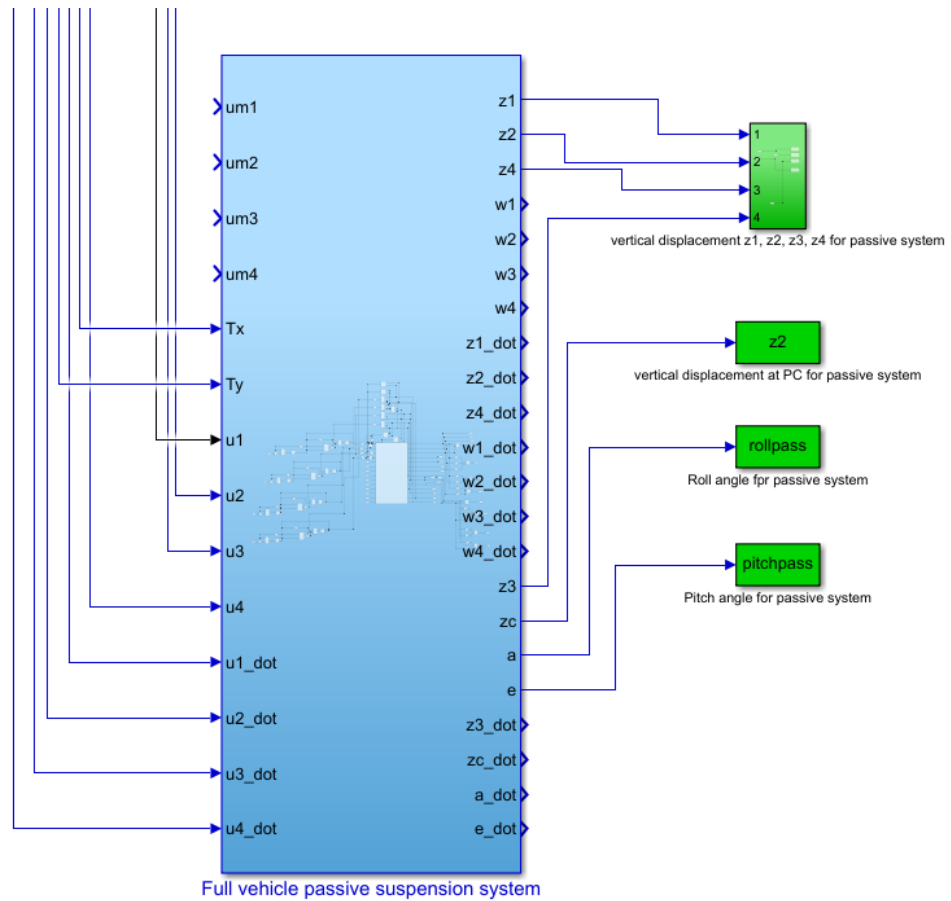

Fig. 5 Block diagram of a full vehicle's passive suspension system.

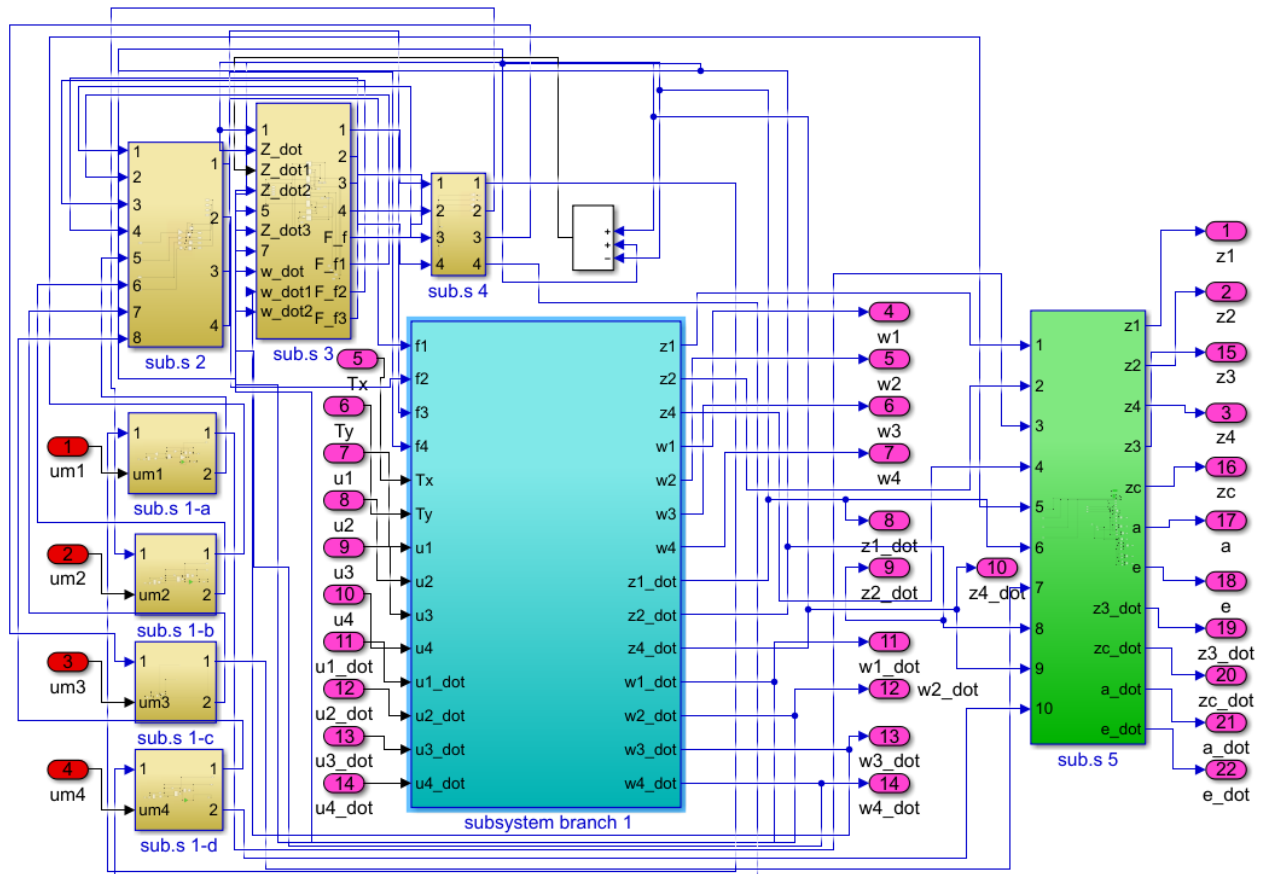

Fig. 6 contents of subsystem of full vehicle regenerative suspension system.

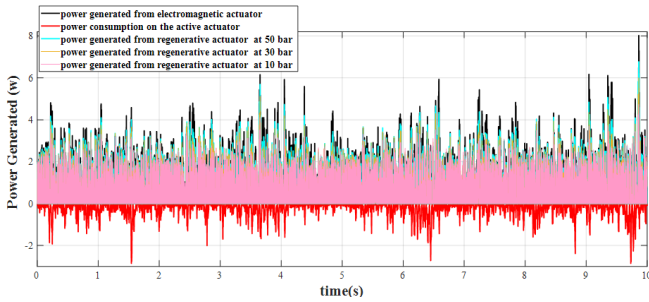

Fig. 7 Comparison of power at the FL suspension.

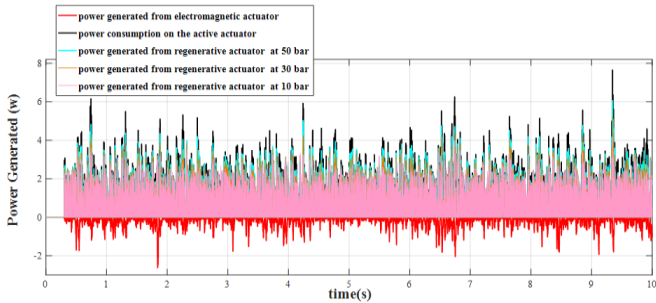

Fig. 8 Comparison of power at the FRL suspension.

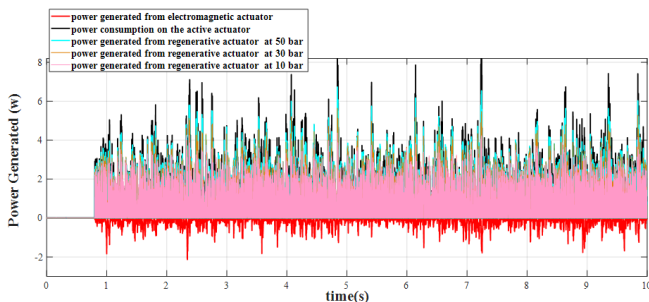

Fig. 9 Comparison of power at the RR suspension.

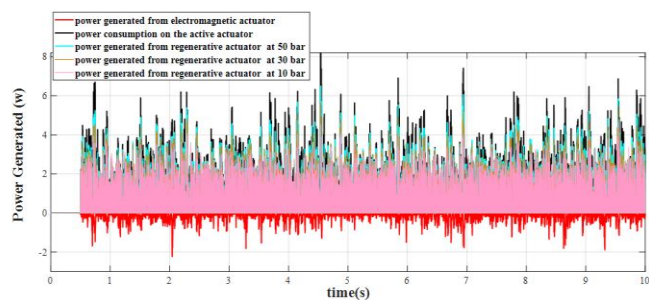

Fig. 10 Comparison of power at the RL suspension.

4.2. Sinusoidal Wave for Active, Electromagnetic and Regenerative System

Measurement of the values of the power harvested and consumed during a time of 10 seconds and amplitude of 1 cm during sinusoidal wave for active system, electromagnetic system and regenerative system (10, 30, and 50 bars).

The comparison of the energy generated between the regenerative system and the electromechanical system and consumed in the active system in sinusoidal wave.

Figures 11-14, shown a close match between the behavior of the active system in terms of energy consumption and the

regenerative system in terms of power generation which gradually decreases as the outlet pressure decreases P_o from which the pressure difference can be determined as mentioned in eq. (2). This reason is attributed to the force that the hydraulic actuator produces F_{ai} . The total energy of each system has an amount of 3.9 W consumption for active system because this system uses electrical energy to rotate a hydraulic pump to pump the hydraulics into the cylinder, which in turn reduces the force transmitted to the vehicle body, and the harvesting energy 2.9, 2.3 and 1.5 W for regenerative at (50, 30 and 10 bars) respectively at ten second where the value of the output pressure can be controlled by the displacements of the spool valves (x_{svi}) as mentioned in eq. (3) and controlled by (FIPID) controller, the reason for the very little energy consumption and generation is due to the fact that the sine wave is not random or sudden, in addition to the fact that the amplitude of the wave used is 1 cm as can also be seen in the response to time in paper [4]. The electromagnetic system shows the behavior of energy harvesting by the rack and pinion system, so we note a different behavior of energy harvest compared to the rest of the aforementioned systems, and the total energy has an amount of - 0.74 W for the same reason mentioned, which shows in paper [4] that the electromechanical system did not work in terms of response with time, but rather matched with the passive system.

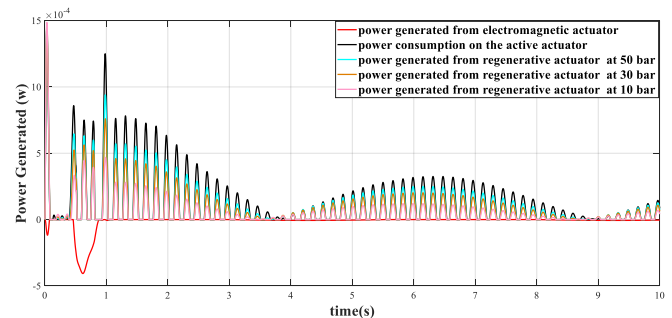

Fig. 11 Comparison of power at the FL suspension.

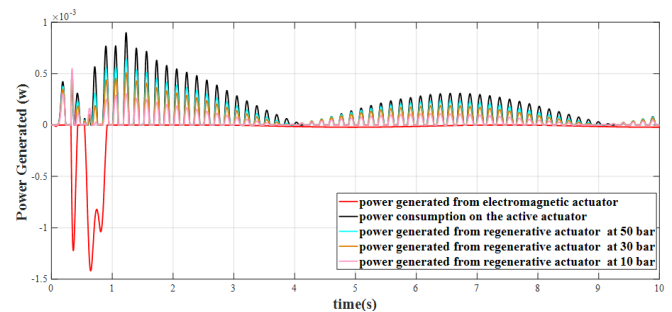

Fig. 12 Comparison of power at the FR suspension.

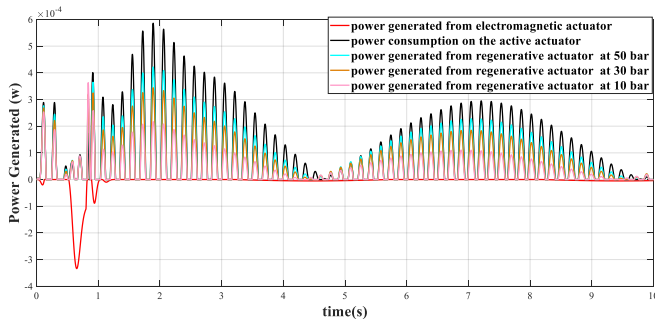

Fig. 13 Comparison of power at the RR suspension.

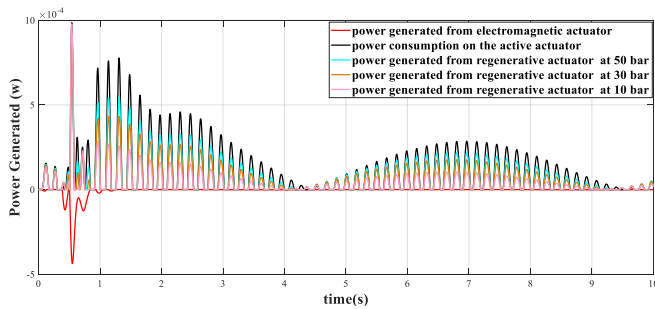

Fig. 14 Comparison of power at the RL suspension.

4.3. Square Wave for Active, Electromagnetic and Regenerative System

Measurement of the values of the power harvested and consumed during a time of 10 seconds and amplitude of 1 cm during square wave for active system, electromagnetic system and regenerative system (10, 30, and 50 bars).

The comparison of the energy generated between the regenerative system and the electromagnetic system and consumed in the active system in square wave.

Figures 11-14 shown a close match between the behavior of the active system in terms of energy consumption and the regenerative system in terms of power generation which gradually decreases as the outlet pressure decreases P_o from which the pressure difference can be determined as mentioned in eq. (2). This reason is attributed to the force that the hydraulic actuator produces F_{ai} . The total energy of each system has an amount of 3.1 kW consumption for active system because this system uses electrical energy to rotate a hydraulic pump to pump the hydraulics into the cylinder, which in turn reduces the force transmitted to the vehicle body, and the harvesting energy 2.5, 2.2, and 1.6 kW for regenerative at (50, 30 and 10 bars) respectively at ten second where the value of the output pressure can be controlled by the displacements of the spool valves (x_{svi}) as mentioned in eq. (3) and controlled by (FIPID) controller. The electromagnetic system shows the behavior of energy harvesting by the rack and pinion system, so can be noted a different behavior of energy harvest compared to the rest of the aforementioned systems, and the total energy has an amount of - 3.4 kW The energy used on the active system is more than the energy expended on this system.

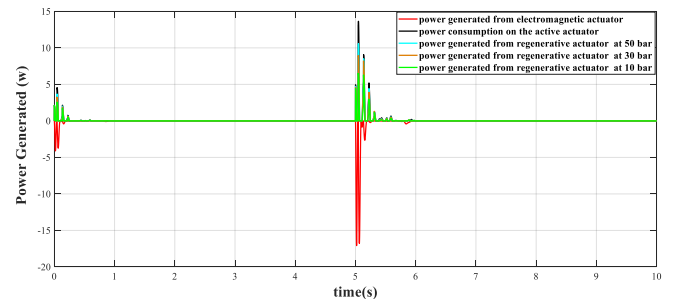

Fig. 15 Comparison of power at the FL suspension.

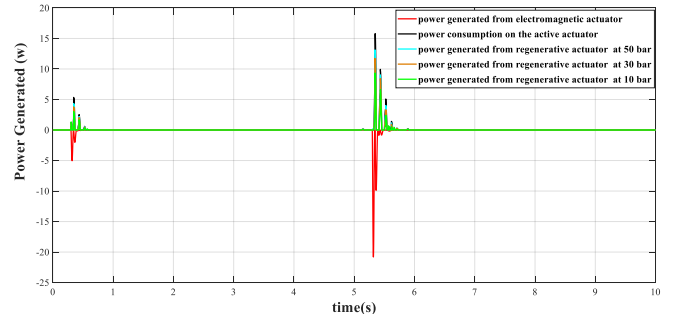

Fig. 16 Comparison of power at the FR suspension.

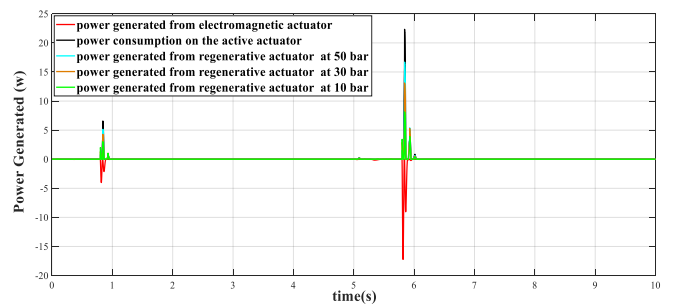

Fig. 17 Comparison of power at the RR suspension.

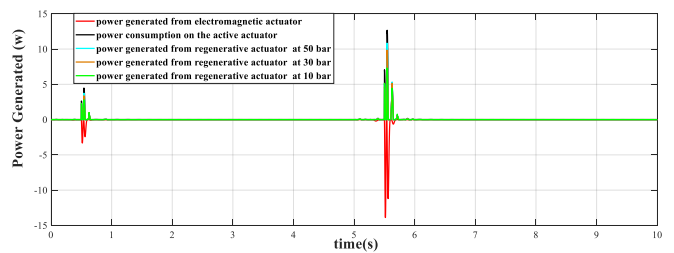

Fig. 18 Comparison of power at the RL suspension.

Table 1 shown the total value of active and regenerative power.

Table 1. total value of consumption power in active suspension system and power harvested in the regenerative suspension system at three level of pressure (10, 30 and 50 bars).

Input signal types	Mode	Total value
Random wave	Active	30.6 kW
	Regenerative at 50 bars	28.7 kW
	Regenerative at 30 bars	27.9 kW
	Regenerative at 10 bars	26.6 kW
Sinusoidal wave	Active	3.9 W
	Regenerative at 50 bars	2.9 W

	Regenerative at 30 bars	2.3 W
	Regenerative at 10 bars	1.5 W
Square wave	Active	3.1 kW
	Regenerative at 50 bars	2.5 kW
	Regenerative at 30 bars	2.2 kW
	Regenerative at 10 bars	1.6 kW

Input signal types	Mode	Total value
Random wave	Percentage of energy %	23.39 %
Sinusoidal wave	Percentage of energy %	19 %
Square wave	Percentage of energy %	9 % (Above the active energy expenditure)

Table 2. shown the total value of active and electromagnetic energy.

Table 2. total value of consumption power in active suspension system and power harvested electromagnetic system relative to the energy consumed in the active system.

Input signal types	Mode	Total value
Random wave	Active	30.6 kW
	Electromagnetic	7.16 kW
Sinusoidal wave	Active	3.9 W
	Electromagnetic	0.74 W
Square wave	Active	3.1 kW
	Electromagnetic	3.4 kW

Table 3. shown the percentage of power saved by regenerative system work relative to the active system.

Table 3. the percentage of power generated in the regenerative system relative to the energy wasted in the active system.

Input signal types	Mode	Total value
Random wave	Percentage of energy % for 50 bars	93.79 %
	Percentage of energy % for 30 bars	91.17 %
	Percentage of energy % for 10 bars	86.9 %
Sinusoidal wave	Percentage of energy % for 50 bars	74.35 %
	Percentage of energy % for 30 bars	59 %
	Percentage of energy % for 10 bars	38.5 %
Square wave	Percentage of energy % for 50 bars	80.64 %
	Percentage of energy % for 30 bars	71 %
	Percentage of energy % for 10 bars	51.6 %

Table 4. shown the percentage of energy saved by electromagnetic system work relative to the active system.

Table 4. the percentage of energy generated in the electromagnetic system relative to the energy wasted in the active system.

5. Conclusions

Simulating energy harvesting for the actuators of the regenerative and electromagnetic system, as well as energy consumption in the active system. include three cases:

1. At random wave there is a close match between the behavior of the active system in terms of energy consumption and the regenerative system in terms of power generation which gradually decreases as the outlet pressure decreases. This reason is attributed to the force that the hydraulic actuator produces. The total energy of active actuator is 30.6 kW and energy of regenerative are 28.7, 27.9 and 26.6 kW at (50, 30 and 10 bars) respectively for ten second. The electromagnetic system shows the different behavior of energy harvesting by the rack and pinion system when compared it with the rest of the aforementioned systems, so we note a behavior of energy harvest, and the total energy - 7.16 kW at ten second.
2. At sinusoidal wave there is a close match between the behavior of the active system in terms of energy consumption and the regenerative system in terms of power generation which gradually decreases as the outlet pressure decreases. This reason is attributed to the force that the hydraulic actuator produces. The total energy of active actuator is 3.9 W and energy of regenerative are 2.9, 2.3 and 1.5 W at (50, 30 and 10 bars) respectively for ten second, the reason for the very little energy consumption and generation is due to the fact that the sine wave is not random or sudden, in addition to the fact that the amplitude of the wave used is 1 cm. The electromagnetic system shows the different behavior of energy harvesting by the rack and pinion system when compared it with the rest of the aforementioned systems, so we note a behavior of energy harvest, and the total energy - 0.74 W at ten second, for the same reason mentioned, the electromechanical system did not work in terms of response with time, but rather matched with the passive system.
3. At square wave there is a close match between the behavior of the active system in terms of energy consumption and the regenerative system in terms of power generation which gradually decreases as the outlet pressure decreases. This reason is attributed to the force that the hydraulic actuator produces. The total energy of active actuator is 3.1 kW for active and the same equation which gives energy 2.5, 2.2, and 1.6 kW at (50, 30 and 10 bars) respectively for ten second. The electromagnetic system shows the different behavior of energy harvesting by the rack and pinion system when compared it with the rest of the aforementioned systems, so we note a behavior of energy harvest, and the total energy - 3.4 kW at ten second, The energy used on the active system is more than the energy expended on this system.

Nomenclature		
Symbol	Description	Unit
Q_{Ldi}	Flow rate through piston	m^3/s
c_{dc}	Discharge coefficient	-
P_{fi}	Pressure feed	N/m^2
P_{di}	Deferent pressure	N/m^2
P_{oi}	Outlet pressure	N/m^2
x_{pi}	The piston's movement within the cylinder	m
F_{hyi}	Actuator hydraulic force	N
F_{ksi}	Spring's force	N
K_{si}	Constant stiffness	N/m
z_i	Vertical displacements at suspensions	m
w_i	Vertical displacements for unsprung masses	m
F_{ci}	Forces of damping	N
c_i	Damping factors	N.s/m
F_{ai}	The hydraulic actuator's actual force	N
F_{fr}	Inside the actuator, there is a frictional force.	N
j_x	Inertia moment in the x-axis	$kg.m^2$
j_y	Inertia moment in the y-axis	$kg.m^2$
T_x	Cornering torque	N.m
T_y	Braking torque	N.m
L_1	Between the sprung mass center of gravity and the front axle	m
L_2	The distance from the sprung mass's center of gravity to the rear axle	m
B	Width of vehicle	m
m_i	Unsprung masses	kg
c_{ii}	Tire damping factor	N.s/m
u_i	The road profile inputs	m
z_c	Center of gravity vertical displacements	m
K_{ti}	Tire stiffness factors	N/m
A_p	Cross section piston area	m^2
P_{regi}	Hydraulic regenerative actuator power	W
P_{treg}	Total hydraulic regenerative actuator power	W
P_{acti}	Hydraulic active actuator power	W
P_{tact}	Total hydraulic active actuator power	W
P_H	The screw's ball-screw lead	m
I	Coils in the motor transmit electric current.	A
Greek Symbols		
Symbol	Description	Unit
ω	Area gradient	-
ρ	Hydraulic density	kg/m^3
δ, Ψ	Actuator parameters	-
μ	Empirical parameter	-
β	Pitch angle	red
Γ	Roll angle	red

Φ	Flux linkage	V.s
v	Relative velocity	m/s

References

- [1] D. Karnopp, "Permanent Magnet Linear Motors Used as Variable Mechanical Dampers for Vehicle Suspensions", *Vehicle System Dynamics*, Vol. 18, Issue 4, PP. 187-200, 1989. <https://doi.org/10.1080/00423118908968918>
- [2] Y. Okada, and H. Harada, "Regenerative Control of Active Vibration Damper and Suspension Systems", *Proceedings of 35th IEEE Conference on Decision and Control*, Kobe, Japan, Vol. 4., pp. 4715-4720, 1996. <https://doi.org/10.1109/CDC.1996.577622>
- [3] Y. Suda, and T. Shiiba, "A New Hybrid Suspension System with Active Control and Energy Regeneration", *Vehicle System Dynamics*, Vol. 25, Issue Sup1, pp. 641-654, 1996. <https://doi.org/10.1080/00423119608969226>
- [4] M. Q. Dinar, H. J. Abid, and H. I. Khalaf, "Enhanced the Damping Efficiency of Hydraulic Regenerative Suspension System Comparing with the Active and Passive Suspension Systems", *Advances in Mechanics*, Vol. 9, Issue 3, pp. 108-125, 2021.
- [5] C. Shian, H. Ren, and L. Senlin, "New Reclaiming Energy Suspension and its Working Principle", *Chines Journal of Mechanical Engineering*, Vol. 13, No. 11, pp. 177-182, 2007.
- [6] H. Ren, C. Shian, and L. Senlin, "A Permanent Magnetic Energy Regenerative Suspension", *ZL 200520072480.9*, 2005.
- [7] C. Shian, H. Ren, and L. Senlin, "Operation Theory and Structure Evaluation of Reclaiming Energy Suspension", *Transactions of the Chinese Society for Agricultural Machinery*, Vol. 37, No. 5, pp. 5-9, 2006.
- [8] Z. Yong-chao, U. Fan, G. Yong-hui, and Z. Xue-chun, "Isolation and Energy regenerative Performance Experimental Verification of Automotive Electrical Suspension", *Journal of Shanghai Jiaotong University*, Vol. 42, No. 6, pp. 874-877, 2008.
- [9] L. Zheng, Y. N. Li, J. Shao, and X. S. Sun, "The Design of a Fuzzy-sliding Mode Controller of Semi-active Suspension Systems with MR Dampers", *Fourth International Conference on Fuzzy Systems and Knowledge Discovery (FSKD 2007)*, pp. 514-518, 2007. <https://doi.org/10.1109/FSKD.2007.565>
- [10] F. A. Ansari, R. Taparia, "Modeling, analysis and control of active suspension system using sliding mode control and disturbance observer", *International Journal of Scientific and Research Publications*, Vol. 3, Issue 1, pp.1-6, 2013.
- [11] Z. Fang, X. Guo, L. Xu, and H. Zhang, "Experimental Study of Damping and Energy Regeneration Characteristics of a Hydraulic Electromagnetic Shock Absorber", *Advances in Mechanical Engineering*, Vol. 5, pp. 1-9, 2013. <http://dx.doi.org/10.1155/2013/943528>
- [12] C. Li, R. Zhu, M. Liang, and Sh. Yang, "Integration of Shock Absorption and Energy Harvesting Using a Hydraulic Rectifier", *Journal of Sound and Vibration*, Vol. 333, Issue 17, pp. 3904-3916, 2014. <https://doi.org/10.1016/j.jsv.2014.04.020>

- [13] L. Xu, Y. Liu, S. Guo, X. Guo and L. Zuo, "Damping Characteristics of a Hydraulic Electric Rectifier Shock Absorber and Its Effect on Vehicle Dynamics", ASME 2015 International Design Engineering Technical Conferences and Computers and Information in Engineering, Boston, Massachusetts, USA, 2016, American Society of Mechanical Engineers Digital Collection. <https://doi.org/10.1115/DETC2015-46916>
- [14] S. Guo, L. Xu, Y. Liu, M. Liu, X. Guo and L. Zuo, "Modeling, Experiments, and Parameter Sensitivity Analysis of Hydraulic Electromagnetic Shock Absorber", ASME 2016 International Design Engineering Technical Conferences and Computers and Information in Engineering Conference, Charlotte, North Carolina, USA, 2016, American Society of Mechanical Engineers Digital Collection. <https://doi.org/10.1115/DETC2016-60390>
- [15] S. Guo, L. Xu, Y. Liu, X. Guo and L. Zuo, "Modeling and Experiments of a Hydraulic Electromagnetic Energy Harvesting Shock Absorber", IEEE/ ASME Transactions on Mechatronics, Vol. 22, No. 6, pp. 2684-2694, 2017. <https://doi.org/10.1109/TMECH.2017.2760341>
- [16] Y. Zhang, H. Chen, K. Guo, X. Zhang, and Sh. E. Li, "Electro-hydraulic Damper for Energy Harvesting Suspension: Modeling, Prototyping and Experimental Validation", Applied Energy, Vol. 199, pp. 1-12, 2017. <https://doi.org/10.1016/j.apenergy.2017.04.085>
- [17] P. Li, and L. Zuo, "Equivalent Circuit Modeling of Vehicle Dynamics with Regenerative Shock Absorbers", ASME 2013 International Design Engineering Technical Conferences and Computers and Information in Engineering Conference, Portland, Oregon, USA, 2013, American Society of Mechanical Engineers Digital Collection. <https://doi.org/10.1115/DETC2013-12759>
- [18] S. Guo, Y. Lui, L. Xu, X. Guo and L. Zuo, "Performance Evaluation and Parameter Sensitivity of Energy-harvesting Shock Absorbers on Different Vehicles," Vehicle System Dynamics, Vol. 54, Issue 7, pp. 918-942, 2016. <https://doi.org/10.1080/00423114.2016.1174276>
- [19] L. Xu, Y. Liu, S. Guo, X. Guo, and L. Zuo, "Damping Characteristics of a Hydraulic Electric Rectifier Shock Absorber and Its Effect on Vehicle Dynamics", ASME 2015 International Design Engineering Technical Conferences and Computers and Information in Engineering, Boston, Massachusetts, USA, 2016, American Society of Mechanical Engineers Digital Collection. <https://doi.org/10.1115/DETC2015-46916>
- [20] A. A. Aldair, "Neurofuzzy Controller Based Full Vehicle Nonlinear Active Suspension Systems", Doctor of Philosophy Thesis, University of Sussex, April 2012. <http://sro.sussex.ac.uk/id/eprint/38502>
- [21] A. A. Aldair and E. B. Alsaedee, "Regeneration Energy for Nonlinear Active Suspension System Using Electromagnetic Actuator", Iraqi Journal for Electrical and Electronic Engineering, Vol. 16, Issue 2, pp. 113-125, 2020. <https://doi.org/10.37917/ijeee.16.2.12>