

Structural behavior of high-strength concrete corbels involving steel fibers or closed stirrups

Saddam Kh. Faleh¹, Aqeel H. Chkheiw², Ihab Sabri Saleh³
^{1,2,3} Department of Civil Engineering, University of Basrah

ABSTRACT

A comprehensive experimental evaluation of the shear behavior of corbels made by high-strength concrete (HSC) with steel fiber or with stirrups was investigated. Thirteen samples were prepared and tested, the main variables in this research were steel fiber type, steel fiber content (V_f %), and amount of horizontal closed stirrups (A_h). The constants in this investigation were the area of the main steel reinforcement (A_s), ratio of shear span to depth (a/d) and cube concrete strength (f_{cu}). The obtained results clearly showed that, the presence of fibers or closed stirrups enhanced the strength and decreased the deformation of the explored specimens. It was concluded that the horizontal shear reinforcement can be substituted by supplementation of steel fibers to RHSC corbels. A comparison was performed between the test results and estimated shear capacity by ACI code and other adopted equations. Very conservative shear strength values were obtained from ACI 318–19 for corbels prepared with high-strength concrete because the strut and tie method were influenced by concrete strength and did not take the contribution of closed stirrups into account. However, the shear friction method depends only on the quantity of the main steel reinforcement and closed stirrups. Russo [2] proposed a model that adequately predicted the ultimate force of high-strength RC corbels incorporating closed stirrups, but this model did not take the effect of steel fibers into account. Campione [3] added the effect of steel fibers by means of the residual tensile strength expression.

Keywords: High-strength concrete, Steel fibers, Shear behavior, Corbels.

Corresponding Author:

Aqeel H. Chkheiw²
Department of Civil Engineering,
University of Basrah, Iraq
Email: aqeel.chkheiw@uobasrah.edu.iq

1. Introduction

For the compensation of beams, corbels are cantilever structural components having a shear span to depth (a/d) ratio smaller than one unit [1], and they are typically used in reinforced concrete constructions. Mostly in pre-cast concrete structures, their functionality is to carry of perpendicular and lateral forces to the main members. Corbels always have abrupt changes in geometry and sustain the point load in support regions. Whereas the load or geometry is changed, “in this paper, combined geometrical and loading discontinuities are achieved”. Many studies were conducted to obtain the empirical and theoretical strengths of such members with-applied to vertical and horizontal loads, which described the influence of the shape, dimensions, type of primary and minor steel re-bars, and concrete grade on the behavior of corbels [4].

Reinforced concrete corbel failure is generally, caused by shearing along the intersection between the corbel and the column, tension tie rebar yielding, compression strut crushing, or localized bearing collapse. As cited in reference [5,] ACI 318, Yong and Balaguru and Russo specified the failure between the diagonal plane and the interface that connects the load point and the bottom point interface, which has also been defined as beam-shear failure, the failure mode frequently detected in experimental exploration.



Corbels are frequently used in conjunction with columns and are subjected to high point loads. Corbel is designed to compensate for the support reaction, but it should also support a horizontal load N_u unless particular efforts are made to eliminate lateral forces induced by constrained shrinkage, creep, or thermal change [6].

HSC has become more popular in recent years due to its advantages over traditional concrete [7]. It is now possible to acquire enhanced concrete qualities because to the development of HSC. Much of the recent research on corbel behavior has focused solely on typical concrete strength. Moreover, many code clauses are also focused on results obtained by testing-concrete cylinders with a compressive strength of not more than 40 MPa [7].

Canha et al. [8] analyzed RHSC corbels for comparing the numerical results with test results. They showed that high strength corbels exhibited very close values between experimental and numerical findings, and the main reinforcement amount, concrete strength, and the existence of secondary reinforcement enhanced the load carrying capacity strength of corbels.

Strength predictions for corbels by determining the strength of concrete struts and nodal zones using the strut-and-tie method (STM) as a rational design of reinforced normal- and- high strength corbels were performed by Yun Y. M. and Lee Y. [9] by predicting the failure strength of 391 RC corbels to examine the proposed strength of the strut and nodal zone. They showed that for the anticipated failure strength matches the experimental values quite well using the suggested numerical technique and strength equations.

In 1985, Yong et al. [10] evaluated eight HSC (406x254x254) mm corbels with (a/d) of 0.39. The quantity of steel rebar and f'_c were the two most important variables. Two of the eight corbels without steel reinforcing unexpectedly collapsed by shear failure at the contact of the column and the corbel. It was found that from the study's findings that the ACI Code 1983[11] requirements are conservative.

A collection of 16 high strength concrete corbels was tested by Yong Y. and Balguru P. [12] in 1994, and two of the total number of specimens were unreinforced. The horizontal point load, ratio of rebars and shear span to depth ratio (a/d) were used as the factors in the study. The stability and ductile type defined by beam shearing failure was the failure of the fourteen reinforced concrete corbels. The volume and distribution of tiny fractures and concrete spalling within the bound region were the significant differences between vertical force-only corbels and those suffering from both vertical and horizontal load concurrently. The experimental The outcomes are contrasted to the formula-based predictions provided in ACI 318–89[13] and the Hagberg truss analogy approach in this study. The procedure described in ACI 318–89 [13] was found to result in a conservative strength calculation. In general, the Hagberg truss analogy approach revealed a good carrying capacity of shear.

Foster et al [14] evaluated the performance of thirty concrete high-strength corbels. The major parameters were a/d ratio, compression strength, and stirrups availability. The following findings were dependent on the experimental results. At the beginning, flexural cracks propagated from the corbel-column interface, and HSC corbels behaved closely to NSC Corbels. Supplying stirrups limited the width of cracks, enhanced ductility, and caused compression strut crushing for beam splitting failure. In HSC corbels, a light amount of horizontal rebar stirrups similar to ordinary strength concrete should be applied.

Ali et al. [15] tested thirteen reinforced high strength concrete corbels that did not have any shear reinforcement. The ratio and scale of the corbel (a/d) were employed as factors in this study. The a/d ratios were 0.25 to 0.7. A comparison of test values with Kriz et al's recommended formulae and ACI 318–99 as given in reference [15] was done to determine the shear strength capability. The test also revealed that the shear failure of the corbels had a modal scale effect, with the factor of safety for bigger corbels being lower than for equivalent smaller corbels. The current methods for predicting final corbels shear strength. The

alternative approaches used to evaluate the ultimate shear for corbels failed to fulfill a large scale of dimensions, with the exception of the ACI 318–99 method, which is appealing in this area.

Saleh et al. [16] investigated the performance of FRC corbels. The essential parameters were fibers ratio (0, 1, 2 and 3%) and a/d ratio. The compression strength and rebars for tension and shear were constant. It was concluded that a substantial improvement in the first crack and ultimate shear strength was obtained particularly with a fiber content between 1 and 2%, and an increase in shearing capacity was obtained with a decrease in a/d ratio from 0.80 to 0.65. The use of short steel fibers in the concrete mix also provides efficient shear reinforcement in corbels and exhibits better control for cracks and even more ductility in corbels.

The current paper is primarily related to investigating the strength and performance of corbels made with RHSC with fibers or horizontal stirrups. Current study variables involve a constant high concrete-compression strength f_{cu} , main steel and a/d ratio, and the variables are the steel fiber content or secondary reinforcement ratio. The shear prediction strength was also determined by ACI 318–19 [1] and methods proposed by other investigators and then compared with experimental results. Furthermore, the corbels contained steel fibers or closed stirrups exhibited pronounced ductile behavior and gain in strength compared to the plain horizontal reinforcement corbels.

2. Research significance

In this investigation the steel fibers contribution to enhance strength of corbels made with high-strength concrete was essential because steel fibers have the advantage of improving ductility, cracking and ultimate load, so that steel fibers can be considered best alternative to stirrups. Additionally, experimental load-carrying capacities corresponding to the available design formulation of the ACI 318 code STM and the shear friction equation [1], empirical equation by Fattuhi [21, 22] and Campione model were evaluated [3].

3. Experimental work

3.1 Materials

Portland cement was the cement used in the investigation. The sand and gravel (12.5 mm) used in this study complies with requirements of ASTM C33. In specimens (2% to 3.5%) of cement weight, a superplasticizer (GLINUM 51) was used. For the longitudinal rebar of the corbels and column and as longitudinal rebar, deformed bars with 12 mm diameters (yield strength = 500 MPa) were used. But for horizontal shear reinforcement is bars of 6 mm and 8 mm in diameter ($f_y = 420$ MPa). For column connections, deformed re-bars having a diameter of 10 mm ($f_y = 440$ MPa) were used. Two types of crimped high-tensile steel fibers were provided with various volume percentages (0.5%, 1.0% and 1.5%), as shown in Figure 1. The steel fiber details used are illustrated in Table 1.

Table 1. Steel fibers properties

Property	Fiber specifications*	
	3cm - straight	5 cm hooked-ends
Density kg/m^3	7850	7850
Ultimate strength MPa	1150	1000
Modulus of Elasticity MPa	200×10^3	200×10^3
Poisson's ratio	0.28	0.28
Average length mm	30	50
Nominal diameter mm	0.375	0.5
Aspect ratio (Lf/Df)	80	100

*From Manufacturer Catalogue



3cm – straight



5 cm hooked-ends

Figure 1. Steel fibers used in this study

3.2 Specimens details

The dimensions of the thirteen specimens are 200 mm width ,300 mm depth, 105 mm shear span and $d = 265$ mm. The geometry and distribution of the steel reinforcement are depicted in Figure 2. The main bars were a constant quantity (339 mm^2), only one corbel was without steel fibers and horizontal stirrups, which was used as the reference specimen. The other twelve corbels were divided into different amounts of steel fibers or with horizontal closed stirrup reinforcement. All details for tested corbels are illustrated in Table 2 and Figure 2. The tested corbels were classified into two groups, and one corbel was denoted C0 as a reference. The first group was identified by the label CFx-n, where the letters CF denote fiber reinforced corbel, x means the fiber length and n refers to the percentage of fiber content. The second group was specified by the label CSR-xn, where the letters CSR indicate shear reinforced corbel, x denotes the horizontal stirrup diameter and n indicates the number of stirrups.

Table 2. Description of the tested corbels

Corbel notation	Main steel	a/d	Type of steel fiber	Fiber content V_f %	V_h %
C0	3Ø12mm	0.4	-----	0	-----
CF3-0.5	3Ø12mm	0.4	Length 3cm	0.5	-----
CF3-1.0	3Ø12mm	0.4	Length 3cm	1.0	-----
CF3-1.5	3Ø12mm	0.4	Length 3cm	1.5	-----
CF5-0.5	3Ø12mm	0.4	Length 5cm	0.5	-----
CF5-1.0	3Ø12mm	0.4	Length 5cm	1.0	-----
CF5-1.5	3Ø12mm	0.4	Length 5cm	1.5	-----
CSR61	3Ø12mm	0.4	-----	-----	1Φ6mm
CSR62	3Ø12mm	0.4	-----	-----	2Φ6mm
CSR63	3Ø12mm	0.4	-----	-----	3Φ6mm
CSR81	3Ø12mm	0.4	-----	-----	1Φ8mm
CSR82	3Ø12mm	0.4	-----	-----	2Φ8mm
CSR83	3Ø12mm	0.4	-----	-----	3Φ8mm

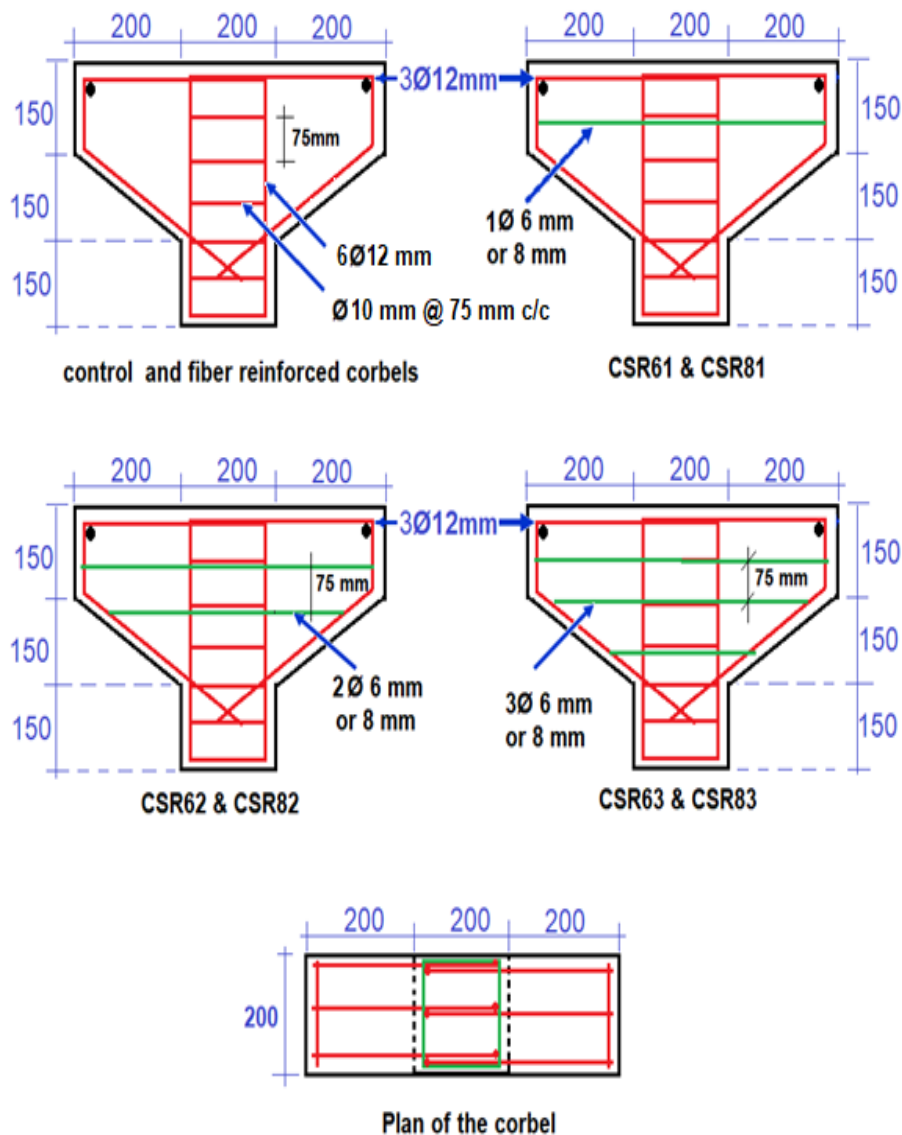

Figure 2. Details of the tested corbels

3.3 Concrete mixture and preparing the specimen

The proportions were chosen from the appropriate test trials to achieve high compressive strength. The adopted mixtures are expressed in Table 3. To obtain the necessary workability, the mixing procedure is a key. A rotary mixer was used with a capacity of 0.03 m^3 . The specimens were cast after homogenous mix was obtained. A steel trowel was completely finished for the upper face of the specimens once casting was completed. The forms were wrapped and left for 3 days with damp canvas, after which the specimens were demolded and covered with damp canvas cloth with polyethylene sheets for 25 days and, subsequently imposed at air temperature and humidity. Finally, the corbels were painted (white color) two days before the tests to enable visual detection of cracks and photographs.

The ingredients/components of the design mixtures used in this work are illustrated in Table 3. A concrete compressive strength was measured by concrete cubes 150 mm side dimension continuously cured in water, three specimens are tested at 28-day age and the average of the results is summarized in Table 3. The Splitting strength measurements were done by using $150 \times 300 \text{ mm}$ concrete cylinders. Characteristic compressive strength for HSC corbels is 80 MPa to 90 MPa with splitting strength from 4.5 to 7.7 MPa.

Table 3. Proportions of mix and properties of concrete

Mixture proportions	Unit	Mix symbol							
		C0	F3-0.5	F3-1.0	F3-1.5	F5-0.5	F5-1.0	F5-1.5	
Water	Kg/m ³	140	139.3	138.6	137.9	139.3	138.6	137.9	
Cement	Kg/m ³	450	447.8	445.5	443.3	447.8	445.5	443.3	
Silica fume (S)	Kg/m ³	50	49.8	49.5	49.3	49.8	49.5	49.3	
Sand	Kg/m ³	670	666.7	663.3	660.0	666.7	663.3	660.0	
Gravel	Kg/m ³	1090	1084.6	1079.1	1073.7	1084.6	1079.1	1073.7	
W/(C+S)	-----	0.28	0.28	0.28	0.28	0.28	0.28	0.28	
Superplasticizer SP	L/m ³	10.0	11.9	14.9	17.2	10.9	13.4	15.3	
Fibers	Content	%	0	0.5	1.0	1.5	0.5	1.0	1.5
	Length	cm	----	3	3	3	5	5	5
Fresh concrete properties									
Slump	mm	200	195	200	198	201	200	200	
Hardened concrete properties									
*Cube compressive strength f_c	MPa	81.5	82.7	85.6	88.2	83.9	87.9	91.75	
Splitting tensile strength f_t	MPa	4.5	5.0	6.7	7.2	5.2	7.1	7.7	

3.4 Test procedure

Figure 3 illustrates the applied load, 0.01 mm per division accuracy dial gauge was used for tracing central deflection of column bottom surface at each load incensement. In an upright center manner, the corbels were tested, as shown in Figure 3. A constant test dimensions ($a=105$ and $d=265$) mm was maintained for all corbels. In its center-marked location, the dial gauge was set. The load increments were in an equal increase of one metric ton (9.81 kN), the vertical deflection of the middle part of the lower surface of the specimen was noted at each load increment; and crack formation was visually inspected to mark the locations, magnitude and size of the first and other resulting cracks. Additionally, when crack propagation was observed, the cracking an final loads were reported for all corbels, after which the load was removed to permit the final crack pattern photos of the corbels to be captured.

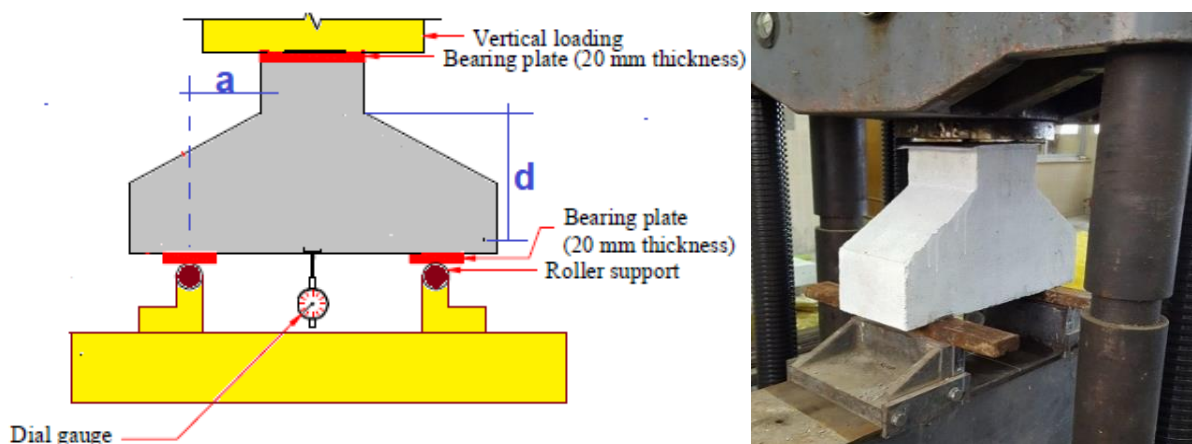

Figure 3. Test set-up of specimens

4. Discussion of test results

4.1 Concrete properties

Using steel fibers in concrete leads to a slight increase in compressive strength and a considerable increase in tensile strength, which may be attributed to the provision of steel fibers leading to a number of significant behavior enhancements in high strength concrete. Table 3, exhibits that compressive strength increase approximately 10% by adding 1.5% steel fibers to the high-strength concrete mix, while the increase in splitting tensile strength was approximately 50% for the same ratio.

In compression, steel fibers may not significantly influence the ascending curve of the compressive stress-strain response. However, they cause the descending post peak response curve to decline in a shallower fashion than the curve of plain concrete, resulting in an increased ductility and toughness (Fanella and Naaman 1985) [16]. The peak compressive strength is not significantly affected, i.e., researchers have observed a maximum strength gain of only 15% (ACI 2002, Fanella and Naaman 1985, Thomas and Ramaswamy 2007). However, the peak strain increases perceptibly with the provision of steel fibers [16].

The inclusion of steel fibers has a much more visible influence on the tensile behavior of the composite of HSC. The material exhibits strain-softening behavior with a standard fiber volume content, but the deterioration in the load-carrying capacity is slower than that of plain concrete. This results in a greater ductility and energy absorbing potential of the material compared to plain concrete. Furthermore, since the fibers bridge the composite cracks and help transfer stresses through the cracks, there are fewer cracks and crack widths than those of ordinary concrete. additionally, for strain-softening materials, if reinforcing bars are present, multiple cracks will form. There would be more cracks with shorter spacing and narrower widths relative to plain concrete [18].

4.2 Cracking examination of specimens

Bending cracks were the first cracks that formed, at approximately half the ultimate shear, these cracks penetrated approximately halfway through the corbel depth, at which stage diagonal stress cracks appeared in the corbels.

These cracks were approximately aligned along a line extending from the junction of the corbel's sloping face and the face of the column to a position between the bearing plates inside the edge and the bearing plate's center. The original length was about one-third of the effective depth of these cracks. The diagonal tension cracks grew in length as the applied shear quickly increased further at first, and then much more slowly as the ultimate load was achieved.

In the specific instance of corbels without stirrups, only one diagonal tension crack in each corbel was effectively created and a very abrupt failure resulted as the concrete sheared through at the head of these cracks. Kriz and Rathas as cited in reference [19] referred to this form of diagonal tension loss as diagonal splitting failure. There were additional inclined cracks for HSC corbels with horizontal stirrups, generally beginning as flexural cracks on the horizontal face of the corbel.

4.3 Ultimate and cracking loads

The cracking and ultimate loads are expressed in Table 4. It can be noticed that, the first cracking load increased for corbels with steel-fibers or horizontal stirrups compared with the reference corbel (C0), where the first crack load of C0 was 260 kN, which increased to 300, 480 and 520 kN for corbels with type F3 steel fiber contents of 0.5, 1.0 and 1.5%, respectively. The cracking load of corbels made by using type F5 steel fibers with addition amounts of 0.5, 1.0 and 1.5% also exhibited an increase compared with corbel C0 to values of 360, 500 and 560 kN, respectively.

The corbels reinforced with horizontal closed stirrups show an approximately constant increase in the cracking load of approximately 370 kN compared with the reference corbel C0, which is equal to 260 kN. The results illustrated that if stirrups were used, there was a considerable increase in the cracking load, and the increase was much greater for steel fiber corbels.

The ultimate load values are explained in Table (4). It seems that increasing the steel fiber content led to an important increase in the ultimate load strength compared with the reference specimen C0. Additionally, it is found that increasing the steel fiber content (V_f %) to 1.5% increases the failure load of the corbel by 24.2% and 27.3% for steel fiber types F3 and F5, respectively. This may be attributed to the behavior of steel fiber in the concrete, which intersect the path of cracks and considerably enhance the ductility and energy absorption [20].

The number and area of stirrups greater than that specified in ACI 318 considerably increase the ultimate strength. Comparing the shear reinforced corbels with the reference specimen C0, an increase of approximately 100% in the horizontal shear reinforcement index ($\rho_h \cdot f_{yh}$) resulted in an increase of approximately 44.4% in the ultimate shear strength, while for CSR62 and CSR82 corbels, an increase of 56.6% was observed, as shown in Table 4. This illustrates that for corbels with a high percentage of shear reinforcement, the contribution of horizontal shear reinforcement to increasing the overall shear strength of the corbels was more effective. This may be related to the closed stirrups parallel to the main tensile reinforcement resisting premature diagonal tension failure of the corbels [ACI 318–19 clause R.16.5.5.2].

Table 4. Test results summary of the tested corbels

Group	Corbel notation	Shear first cracking load (kN)	Ultimate load (kN)	Increasing in cracking load %	Increasing in ultimate load %
Control	C0	260	990	0.0	0.0
1a	CF3-0.5	300	1125	15.4	13.6
	CF3-1.0	480	1220	84.6	23.2
	CF3-1.5	520	1230	100.0	24.2
1b	CF5-0.5	360	1200	38.5	21.2
	CF5-1.0	500	1240	92.3	25.3
	CF5-1.5	560	1260	115.4	27.3
2a	CSR61	370	1320	42.3	33.3
	CSR62	375	1430	44.2	44.4
	CSR63	372	1540	43.1	55.6
2b	CSR81	371	1400	42.7	41.4
	CSR82	371	1550	42.7	56.6
	CSR83	380	1600	46.2	61.6

4.4 Deflection

The deflections were determined by a digital dial gauge with 0.01 mm precision at the center of the corbel, as shown in Figure 3. The load-deflection relationship for reinforced concrete corbels with steel fibers is shown in Figure 4, and Figure 5. The figures illustrated that the increase in the steel fiber content for corbels causes a decrease in the magnitude of deflection. At a load of 400 kN, the deflection magnitudes are 1.6 mm, 1.04 mm and 1.02 mm for C0, CF3–1.5 and CF5–1.5 corbels, respectively. For a specified level of load of 400 kN, an increase in the horizontal shear reinforcement ratio was related to a decrease in the deflection values.

It may be interpreted that SF or horizontal stirrups slows the initiation and extension of cracks and increases the resistance to cracking of concrete. On the other hand, as the quantity of steel fibers increases, the deflection decreases at a certain load level. It was observed that the corbels with steel fibers or stirrups, as secondary reinforcement, sustain large deformations before failure than the corbel without secondary reinforcement, so a greater ductility is observed.

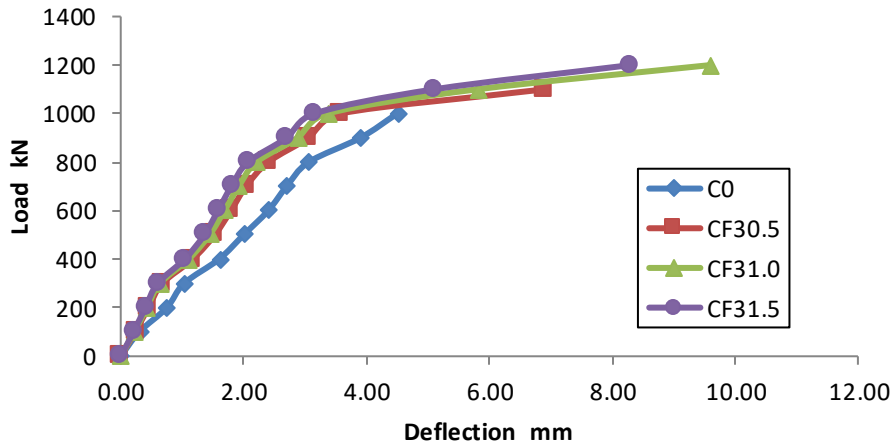

Figure 4. Load-deflection curve of group 1a corbels

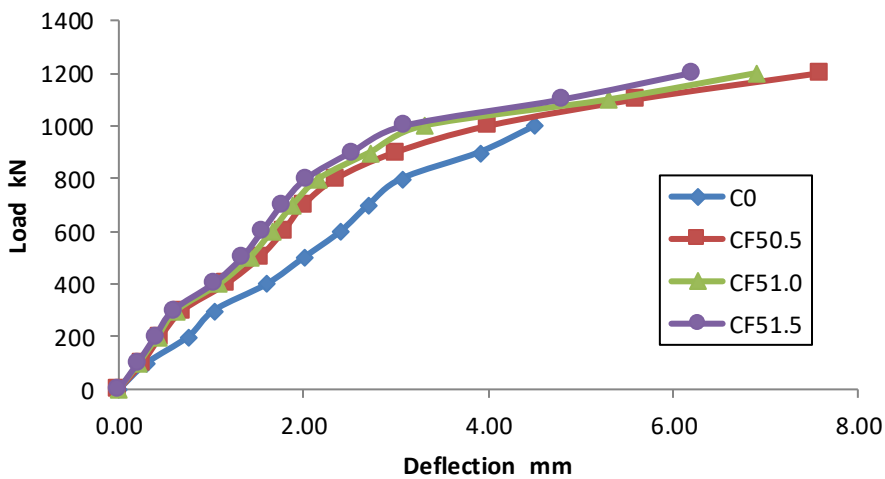

Figure 5. Load-deflection curve of group 1b corbels

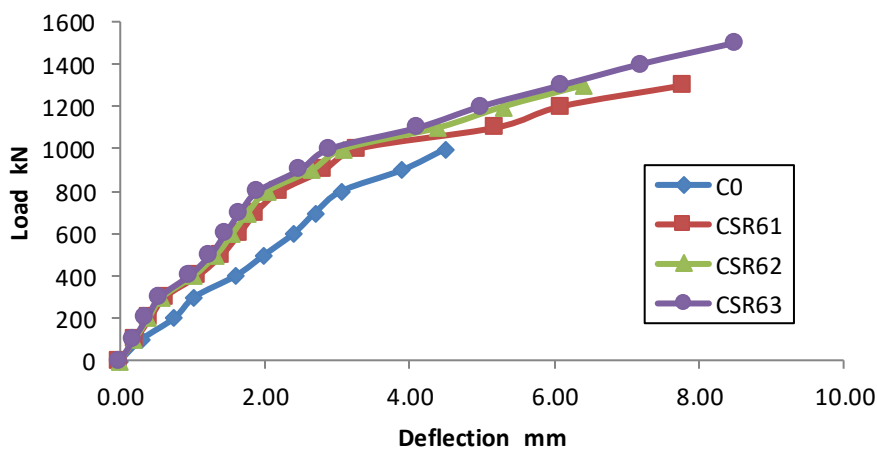

Figure 6. Load-deflection curve of group 2a corbels

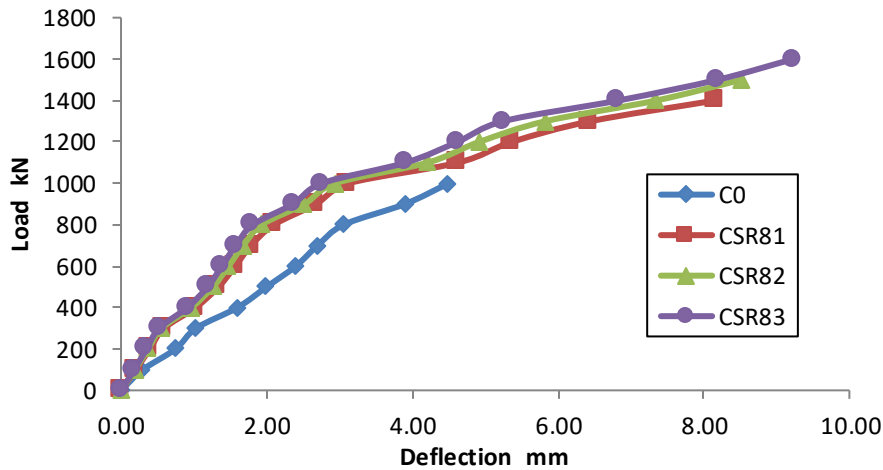

Figure 7. Load-deflection curve of group 2b corbels

4.5 Failure modes

The mode of failure for all corbels having steel fibers was obviously inclined shear, as shown in Table 5 and Figure 8, whereas the control corbel lacked steel fibers and failed by diagonal tension. The strength and ductility of corbels with stirrups increased when steel fibers were introduced as secondary reinforcement, and the ductility improvement was considerably larger [20]. The insert of steel fibers has a much more significant effect on the tensile behavior of the matrix. The material demonstrates strain-softening behavior at a typical fiber volume percentage but exhibits slower degradation in the load carrying capacity relative to plain concrete. This results in a greater ductility and energy absorbing potential of the matrix than plain concrete. Moreover, since the fibers bridge the cracks in the composite and assist in the transfer of stresses across the cracks, the widths of the cracks are smaller than those of plain concrete. Additionally, for a strain-softening material, several cracks will develop if shear reinforcing bars are present. There would be more cracks with shorter spacing and smaller widths relative to plain concrete [18].

Table 5. Modes of failure

Group	Corbel notation	Mode of failure
Control	C0	Inclined shear
1a	CF3-0.5	
	CF3-1.0	
	CF3-1.5	
1b	CF5-0.5	
	CF5-1.0	
	CF5-1.5	
2a	CSR61	
	CSR62	
	CSR63	
2b	CSR81	
	CSR82	
	CSR83	



Figure 8. Typical crack pattern of some tested specimens

4.6 Comparison between actual and predicted shear strengths

Several theoretical models (equations and formulas) were adopted to estimate the shear point load carrying capacity of reinforced concrete corbels, e.g., the ACI 318 code method [1] shear friction method and STM, Fattuhi 1986 and 1994 [22, 23], Foster et al. 1996 [14], Russo et al. 2006 [2] and G. Compione et al. [3].

Table 6, attempts to compare the experimental values of the corbel capacity and those calculated from the above equations. The shear prediction of the STM is more conservative than that of the shear-friction method for corbels containing sufficient horizontal reinforcements because it did not take into consideration the minor contribution of horizontal shear reinforcement in resisting shear. For high-strength steel fiber corbels reinforced with only the main reinforcement, the STM is a more reasonable prediction of the failure load than the SF method because it takes into consideration the strut compressive strength. Table (6) also illustrates the comparison between the experimental magnitudes of the corbel capacity and those calculated from the above equations, as illustrated in Columns 10 to 16. The Russo expression [2] satisfactorily estimates the ultimate load for high-strength corbels with and without secondary shear reinforcement with a mean value of 1.59. However, the results of the Fattuhi equation [21] and G. Campione expressions [3] revealed that the optimal model matches the test results. G. Campione [3] expressed a reasonable extent of approximation for steel fiber contribution in reinforced concrete corbels compared with certain other available models.

Table 6. Experimental and predicted results

Column No.	1	2	3	4	5	6	7	8	9	10	11	12	13	14	15	16
Corbel notation	a/d	Test Results Vu (kN)	ACI 318-19 Vu (kN) Shear - Friction	ACI 318-19 Vu (kN) STM method	Fattuhi 1986 Vu (kN)	Fattuhi 1994 Vu (kN)	Foster et al 1996 Vu (kN)	Russo et al 2006 Vu (kN)	G. Campione et al 2007 Vu (kN)	Vu Test Vu Shear friction	Vu Test Vu STM	Vu Test Vu Fattuhi 1986	Vu Test Vu Fattuhi 1994	Vu Test Vu Foster	Vu Test Vu Russo	Vu Test Vu Campione
C0	0.4	495	237.3	300	201.7	315.7	296.8	391	200.5	2.09	1.65	2.45	1.57	1.67	1.27	2.47
CF3-0.5	0.4	562.5	237.3	305	237.4	327.8	296.8	392	240.4	2.37	1.84	2.37	1.72	1.90	1.43	2.34
CF3-1.0	0.4	610	237.3	310	273.1	363.9	296.8	393	277.6	2.57	1.97	2.23	1.68	2.06	1.55	2.20
CF3-1.5	0.4	615	237.3	312	308.8	373.4	296.8	398	328.3	2.59	1.97	1.99	1.65	2.07	1.55	1.87
CF5-0.5	0.4	600	237.3	308	242.8	332.4	296.8	392	294.1	2.53	1.95	2.47	1.81	2.02	1.53	2.04
CF5-1.0	0.4	620	237.3	312	283.8	371.6	296.8	398	402	2.61	1.99	2.18	1.67	2.09	1.56	1.54
CF5-1.5	0.4	630	237.3	315	324.8	382.5	296.8	403	513.5	2.65	2.00	1.94	1.65	2.12	1.56	1.23
CSR61	0.4	660	270.5	300	-	-	296.8	405	227	2.44	2.20	-	-	-	1.63	2.91
CSR62	0.4	715	303.7	300	-	-	296.8	420	110	2.35	2.38	-	-	-	1.70	6.50
CSR63	0.4	770	337.0	300	-	-	296.8	433	140	2.28	2.57	-	-	-	1.78	5.50
CSR81	0.4	700	296.4	300	-	-	296.8	415	100.5	2.36	2.33	-	-	-	1.69	6.97
CSR82	0.4	775	355.5	300	-	-	296.8	440	160	2.18	2.58	-	-	-	1.76	4.84
CSR83	0.4	800	414.6	300	-	-	296.8	465	222	1.93	2.67	-	-	-	1.72	3.60
Mean										2.38	2.16	2.23	1.68	1.99	1.59	3.39
Standard deviation (SD)										0.22	0.32	0.21	0.07	0.16	0.14	1.93
Coefficient of variation (COV) %										9.2	14.7	9.5	4.3	8.0	8.9	57.1

5. Conclusions

Only after reaching their ultimate load the corbels reinforced with the primary reinforcement fail in a brittle manner. Steel fibers were suitable for use in reinforced concrete corbels as shear reinforcement and led to improved strength and ductility.

Changing the volume fraction of SF to 0.8% leads to a rise of approximately 44.4% and 36.1% in cracking and maximum loads, respectively. Thus, the addition of adequate steel fiber quantity greatly enhanced the corbel load carrying capacity.

The load-deflection relationship of high-strength reinforced concrete corbels is heavily influenced shear span. As the a/d ratio increases, the behavior becomes dramatically nonlinear, and the load-deflection performance is influenced by $f'c$ of concrete slightly.

It was observed that as ($f'c$) increases, the response is slightly stiffer. It is also adequately influenced by the quantity of steel fibers (vf). If the fiber content increases, a stiffer response is noticeable, especially 0.8% fibers are used and with a larger (a/d) ratio.

The common STM and SF methods proposed by the American code were highly conservative in computing the shear capacity of high-strength corbels. For high-strength steel fiber corbels reinforced with only main reinforcement, the STM presented preferable predictions of the load capacity compared to the SF method.

Using Russo's [2] approach, the design formulas for strength of high-strength concrete corbels provided more accurate predictions. Nonetheless, steel fibers were not thought to have any effect on strength. G. Campione [3] proposed a closed expression to account for the contribution of steel fibers.

References

- [1] ACI Committee 318, "Building Code Requirements for Structural Concrete (ACI 318-19) and Commentary (318R-19)," American Concrete Institute, Farmington Hills, Mich., 2019, 623 pp.
- [2] G. Russo, R. Venir, M. Pauletta, and G. Somma, "Reinforced Concrete Corbels—Shear Strength Model and Design Formula", ACI Structural Journal, vol. 103, no. 1, Jan.-Feb. 2006, pp. 3-10.
- [3] G. Campione, L. M. Lidia, and L. M. Maria, "Steel Fiber-Reinforced Concrete Corbels: Experimental Behaviour and Shear Strength Prediction", ACI Structural Journal, vol. 104, no. 5, Sep.-Oct. 2007, pp. 570-579.
- [4] A. M. Abdel Hafez, M. M. Ahmed, H. Diab, and A. M. Drar, "Shear Behaviour of High-strength Fiber Reinforced Concrete Corbels", Journal of Engineering Sciences, Assiut University, vol. 40, no. 4, Jul. 2012, pp. 969-987.
- [5] K. H. Yang, & A. F. Ashour, "Shear Capacity of Reinforced Concrete Corbels Using Mechanism Analysis", Proceedings of the ICE-Structures and Buildings, 165(3), 2012, pp. 111-125.
- [6] A. M. Nilson, D. Darwin, and Ch. W. Dolan, "Design of Concrete Structures", Thirteen Edition, 2004.
- [7] O. Q. Aziz, and Z. S. Othman, "High-strength Concrete Corbels Subjected to Vertical Loads", Journal of Al-Rafidain Engineering, vol. 18, no. 1, Jan. 2010, pp. 1-12.
- [8] M. F. Canha, D. A. Kuchma, M. Kh. El Debs, and R. A. de Souza, "Numerical Analysis of Reinforced High Strength Concrete Corbels" Engineering Structures Journal, 74, 2014, pp. 130-144.
- [9] Y. M. Yun, and Y. Lee, "Strengths of Struts and Nodal Zones for Strut-and-Tie Model Design of Reinforced Concrete Corbels", Civil Engineering Journal, vol. 7, no. 8, Aug. 2021, pp. 1275-1289.
- [10] Y. Yong, D. H. McCloskey, and E. G. Nawy, "Reinforced corbels of high-strength concrete", London, UK: ACI Special Publication, 87, 1985.
- [11] ACI Committee-318, "Building Code Requirements for Reinforced Concrete (ACI 318-83) and Commentary", American Concrete Institute, Detroit, Michigan, USA, 1983.
- [12] Y. Yong, and P. Balagur, "Behaviour of reinforced high-strength concrete corbels", Journal of Structural Engineering, 120(4), 1994, pp. 1182-1201.

- [13] ACI Committee-318, “Building Code Requirements for Reinforced Concrete (ACI 318-89) and Commentary”, American Concrete Institute, Detroit, Michigan, USA, 1989.
- [14] S. J Foster, R. E. Powelland, H. S. Selim, “Performance of High- Strength Concrete Corbels”, ACI Structural Journal, vol. 93, no. 5, Sept.- Oct. 1996, pp. 555-563.
- [15] A. R. Yousif, “Prediction of Ultimate Load Capacity of High-Strength Reinforced Concrete Corbels”, Journal of Al-Rafidain Engineering, vol.17, no.4, Aug. 2009, pp. 12-27.
- [16] A. Saleh, A. Fathy, A. Farouk, and M. Nasser, “Performance of Steel Fiber Reinforced Concrete Corbels”, International Research Journal of Innovations in Engineering and Technology (IRJIET), vol. 3, Issue 2, Feb. 2019, pp. 22-27.
- [17] European Standard EN 1992-1-1, December 2004.
- [18] A. E. Kurtoglu, M. E. Gulsan, H. A. Abdi, M. A. Kamil, and A. Cevik, “Fiber Reinforced Concrete Corbels: Modeling Shear Strength Via Symbolic Regression”, Journal of Computers and Concrete, vol. 20, no.1, 2017, pp. 001-010.
- [19] N. I. Fattuhi, and B. P. Hughes, “Ductility of Reinforced Concrete Corbels Containing Either Steel Fibers or Stirrups,” ACI Structural Journal, vol. 86, no. 6, Nov.-Dec. 1989, pp. 644-651.
- [20] H. M. S. Abdul-Wahab, “Strength of Reinforced Concrete Corbels with Fibers”, ACI Structural Journal, Title no. 86-S7, Jan. -Feb. 1989.
- [21] N. I. Fattuhi, "Corbels with Shear Reinforcement in the Form of Stirrups or Fibres" Proceedings, 3rd RILEM International Symposium on Developments in Fibre Reinforced Cement and Concrete, University of Sheffield, July 1986, vol. 2, Paper No. 8.8.
- [22] N. I. Fattuhi, “Reinforced corbels made with plain and fibrous concretes”, ACI Structural Journal, vol. 91, no. 5, 1994, pp. 530-536.