

Effect of Web Opening on the Ultimate Capacity of Steel Plate Girders under Two Points Load

Dr. Mazin A. Al-Mazini

Engineering College, University of Basrah /Basrah,.

Email: almazini_engineer@yahoo.com

Received on:5/7/2015 & Accepted on: 12/11/2015

ABSTRACT

The structural behavior of steel plate girders with web opening is investigated in this study. An experimental and theoretical investigation of plate girders with circle and square openings in the web was conducted. The experimental work included testing of seven plate girder specimens under two point loads. Three specimens were tested to observe the influence of the circular web opening. The influence of the presence of square web openings was studied by testing other three specimens. The last one was tested without opening as a reference (control) specimen. These specimens had the same dimensions. The experimental results showed that the ultimate load capacity of the girders decreases with increasing the opening size, and the position of plastic hinge depends on the size of hole.

Three-dimensional nonlinear finite element analysis has been used to conduct the numerical investigation of the structural behavior of plate girders with web opening. ANSYS (version 12.0) computer program was used in this study. Four- nodes shell element (SHELL 181) was used to represent the steel plate. The proposed finite element model has been used to carry out a parametric study to investigate the effects of two parameters; web slenderness and flange stiffness ratios, on the ultimate load capacity of plate girders with circular web openings.

Keywords: Experimental investigation, plate girders, web opening, ultimate load behavior, finite element method.

Notations

b wide of web panel

d deep of web

b_f wide of flange

d_o diameter of circle or square side

t_f thickness of flange

t_w thickness of web

تأثير الفتحة في وترات الروافد اللوحية الفولاذية على الحمل اللاقصى تحت حمل نقطتين مركزيتين

الخلاصة

في هذه الدراسة تم بحث السلوك الانشائي للعوارض اللوحية ذات الوترات المثقوبة تمت الدراسة عمليا ونظريا للعوارض اللوحية ذات فتحات دائرية ومربعة الشكل. تم فحص سبعة نماذج وتحت تأثير نقطتين تحميل. فحصت ثلاث نماذج لمعرفة تأثير وجود الفتحات الدائرية الشكل وثلاث نماذج اخرى فحصت لمعرفة تأثير وجود الفتحات المربعة الشكل. بينما النموذج السابع كان بدون فتحات في وتراتها حيث يمثل النموذج المرجع (المقارنة) لبقية النماذج.

اظهرت النتائج العملية على أن الحمل الأقصى للعوارض اللوحية يقل بزيادة حجم الفتحة وكذلك أن موقع المفصل البلاستيكي يعتمد على حجم الفتحة.

استخدام التحليل اللاخطي للعناصر المحددة باستخدام البرنامج الجاهز (ANSYS version 12) لمعرفة السلوك الإنشائي للعوارض اللوحية التي تم فحصها عمليا وتم استخدام SHELL181 لتمثيل صفائح الحديد لغرض تمثيل النموذج في البرنامج. دراسة تأثير عاملين هما نسبة النحافة وجساءة الشفة العليا على الحمل الأقصى للعوارض اللوحية ذات الوترات المثقوبة بثقوب دائرية الشكل.

INTRODUCTION

A plate girder is a beam built up from plate elements to achieve more efficient arrangement of material than is possible with rolled sections. Plate girders are normally designed to support heavy loads over long spans in situations where it is necessary to produce an efficient design by providing girders of high strength to weight ratio. Flanges resist applied moment, while web plates maintain the relative distance between flanges and resist shear. To produce the lowest axial flange force for a given bending moment, the web depth must be made as large as possible. To reduce the self weight, the web thickness must be reduced to minimum. As a consequence, in many instances the web plate is of slender proportions and is therefore prone to buckling at relatively low values of applied shear^[1].

Various forms of instability, such as shear buckling of web plates, lateral-torsional buckling of girders, compression buckling of webs, and local buckling and crippling of webs are considered in the design procedures.

Due to the slenderness of web plates, they buckle at early stages of loading; therefore, one important design aspect of plate girders is the shear buckling and failure of web elements. The web of the plate girder buckles at a stress that can be calculated from the theory of plate buckling. After buckling of the web, the stress distribution in the web changes and additional post buckling strength is mobilized^[2].

The behavior of a plate girder subjected to an increasing shear load may be divided into three phases as shown in Figure (1). Prior to buckling, equal tensile and compressive principal stresses are developed in the plate as shown in Figure (1-a). In the post-buckling range no more increase in compressive stress is possible and only an inclined tensile membrane stress field is developed, as shown in Figure (1-b). The magnitude of the tensile membrane stress is indicated by σ_t in Figure (1-b) and its inclination to the horizontal is shown as θ . Since the flanges of the girder are flexible they will be bent inwards under the pull exerted by the tension field. Further increase in the load will result in yield occurring in the web under the combined effect of the membrane stress field and the shear stress at buckling. The value of σ_t at which yield occurs is identified as the basic tension field strength failure of the girder occurs when four plastic hinges form in the flanges of the girders, as shown in Figure (1-c). The resulting collapse mechanism then allows a shear displacement to occur as indicated^[3 and 4].

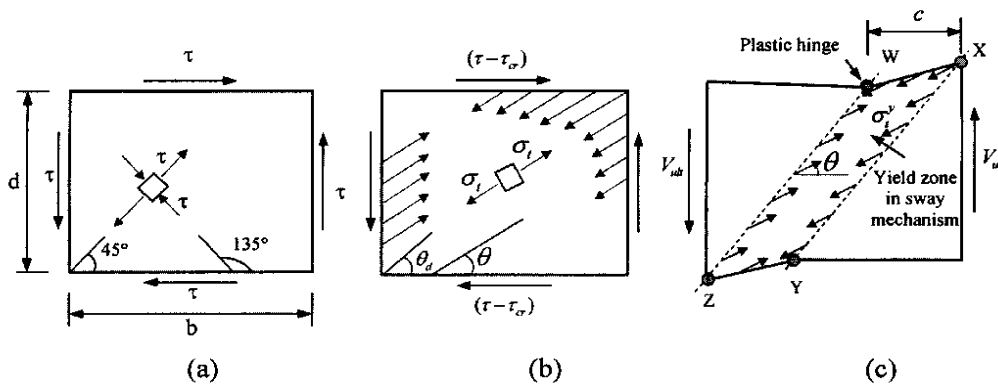

Figure (1): Phase in girder behavior up to collapse (a) Unbuckling behavior (b) Post-buckling behavior (c) Collapse behavior.

Openings in webs

Openings in the webs of plate girders are necessary to facilitate inspection and for providing service. The introduction of openings in a web results in stress distribution within the member and causes a reduction in its strength and stiffness.

Due to limitation on maximum allowable deflection, the high strength properties of structural steel cannot always be utilized to best advantages. As a result several new methods have been aimed at increasing the stiffness of steel members without any increasing in weight of the steel required. Beam with web opening was one of these solutions. The shape of the web opening will depend upon the designer's choice and the purpose of the openings^[5].

Hoglund (1971)^[6] researched the effects of rectangular and circular holes on the shear performance of plate girders with thin webs subjected to static loading. He found that when holes were placed in the areas of high shear force, the reduction in shear capacity was high. Baranda et al. (1978)^[7] stated that the flexural capacity of sections with web openings was reduced by approximately 2 to 5%. The minimal reduction in flexural capacity is a result of the section mid-depth being a region of reduced bending stresses. Redwood and Shrivastava (1980)^[8] stated that openings less than 30% of the section height will not cause a significant reduction to the flexural capacity. Narayanan and Der Avanessian (1984)^[9] studied the plate girders containing centrally located reinforced circular web openings and developed an equilibrium model for predicting the ultimate capacity of such girders. Hamoodi and Hadi (2011)^[10] investigated experimentally the structural behavior of simply supported composite beams, in which a concrete slab is connected together with a steel I-beam by means of headed stud shear connectors under the presence of web opening. Hamoodi and Abdul Gabar (2013)^[11] presented an experimental investigation to study the behavior of circular opening at the center of plate girder and the effect of the installed of a reinforced strip around that circular opening on the ultimate shear load.

Aim of the study

The objective of the work reported in this study is to assess the effectiveness of the hole in the web. The following parameters were considered in this study: (a) hole size and (b) hole shape (circular or square). The study consists of two parts; the first part is to investigate experimentally seven simply supported plate girders with web opening. The second part deals with the analysis of the tested beams theoretically. The finite element method, using the software ANSYS version 12.0, is used to model the plate girder specimens. The validity of the used analysis is examined with the results of the experimental work.

Experimental investigation

Details of test specimens

Tests were carried out on seven plate girder specimens. One of these specimens was a control beam and the other six specimens were divided into two series (A and B). Series A indicates the plate girder with circular web opening and series B represents the plate girder with central square web opening. For all girders, nominal overall depth of the girders was maintained at 312 mm with top and bottom flanges of nominal width of 200 mm and nominal thickness of 6 mm. Each girder consists of web panels 400 mm wide (b), 300 mm deep (d) and 2 mm thick (t_w). The nominal value of d/t_w ratio was, therefore, 150 and the nominal web aspect ratio (b/d) was 1.33. Nominal dimensions of the girders are summarized in Table (1). And details of the girders are shown in Figure (2).

The influence of the presence of central circular web openings on the ultimate strength was studied by using three different size hole diameters 50, 100, and 150 mm. Also, three different sizes of central square web openings (50x50, 100x100, and 150x150 mm) was used to investigate the effect of the square openings on the ultimate strength.

Fabrication of test specimens

Fabrication of specimens was carried out in accordance with the details shown in Figure (2). Hot rolled steel plates of Grade 250 for all specimens were used. As far as possible, the webs were cut from single sheets obtained from a single rolling. Flanges were also obtained from the same rolling and they were measured appropriately and cut from the plate using flame. Once all components were ready, the girders were assembled by tack welding flange plates to top and bottom of the web plate and, stiffeners to the web and flanges, before full welding was made. After making sure that the girder was assembled according to the required dimensions, continuous fillet welding was carried out with E43 electrodes. Openings were marked and cutout from the web plates by saw cut.

Tensile test coupons were cut from the same plate used for the flange and web and were tested in tension accordance with ASTM A36 specifications. The test result shows that the average yield stress and modulus of elasticity for the web and flange material are 250 MPa and 200000 MPa, respectively.

Table (1): Details of the tested plate girders

Series	Girders designation	Shape of opening	d_o	d_o/d
Control	Bo	----	----	----
A	BC1	Circle	50	0.17
	BC2		100	0.33
	BC3		150	0.5
B	BS1	Square	50	0.17
	BS2		100	0.33
	BS3		150	0.5

• d_o is the diameter of circle or square side

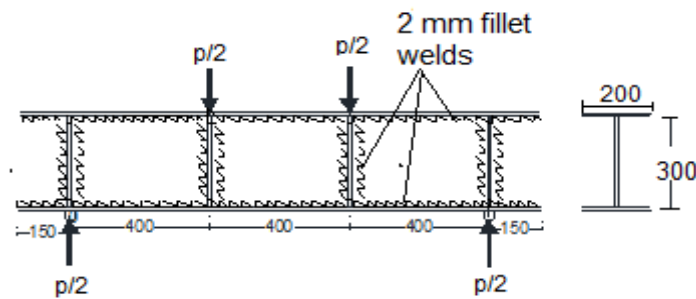

a) solid web plate girder

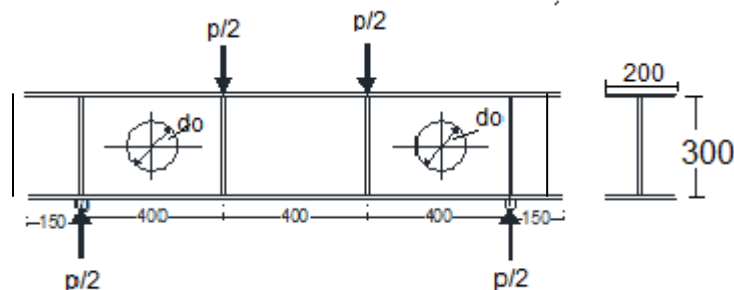

b) plate girder with circular web openings

Figure 2: Dimensions and details of plate girders

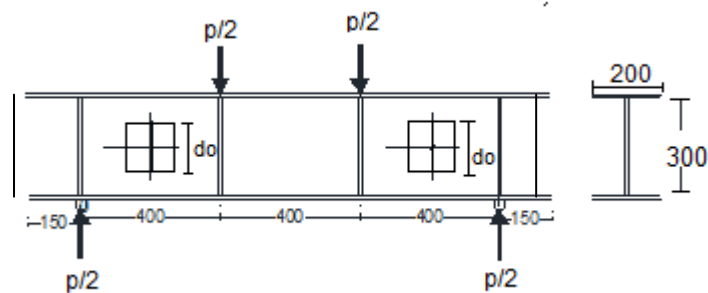

c) plate girder with square web openings
Figure 2: Continued

Instrumentation and test procedure

The instrumentations were used to detect the structural behavior of the beams at every stage of loading. Torsen's Universal Testing Machine with a capacity of 200 ton was used to apply the load. Figure (3) depicts the test setup. During each load step, the corresponding vertical displacement (deflection) at the beam mid-span was measured by using a dial gauge with magnetic base. The accuracy of the dial gauge is 0.01 mm.

The girders were tested as simply supported under two point loading. The load was static and gradually increased up to failure. The test was terminated when the total load on the specimen started to drop off.



Figure (3): Test setup.

The load was applied using a stiff steel spreader beam. The inner two point loads were applied over two transverse steel plates, which covered the entire width of the specimen. Steel rollers were placed between the spreader beam and each of the steel plates which will present the support reaction loads. In both bearings, rotation and movement along the longitudinal axis were allowed.

Finite element analysis

In parallel with the experimental work, finite element (FE) models were constructed in the ANSYS Version 12.0 program for each of the tested beams. Material properties which have been used in experimental work for all girders are adopted in this analysis. Table (2) presents the properties of steel entered in the program. A bilinear isotropic material model with von Mises yield criterion was used for the steel material to model the nonlinear material behavior of the beam. The support and loading conditions of experimental girders were simulated in the

analytical model by restraining the appropriate degrees of freedom. The webs and flanges were modeled by a SHELL181 element. This element is suitable for analyzing thin to moderately-thick shell structures. It is a four-nodal element with six degrees of freedom at each node: translations in the x, y, and z directions, and rotations about the x, y, and z axes.

Table (2): Properties of steel used

Linear isotropic	
Elastic moduli (Es) MPa	200000
poisson's ratios (ν)	0.3
Bilinear isotropic hardening	
Yield stress (F _y) MPa	250
Tangent modulus (ES2) Mpa	2000

To ensure that the model acts in the same way as the experimental tested beams, boundary conditions need to be applied at the plane of symmetry, and where the supports and loadings exist. The symmetry boundary conditions were set first. The model being used is symmetric about one plane. To represent the symmetry, nodes on this plane must be constrained in the perpendicular direction. Therefore, the displacement in x-direction is equated to zero for all the nodes at the plane of symmetry perpendicular on x-direction as shown in Figure 4. The support was modeled in such a way that a roller was created. One line of nodes was given constraint in the y-direction, by doing this the beam will be allowed to rotate at the support.

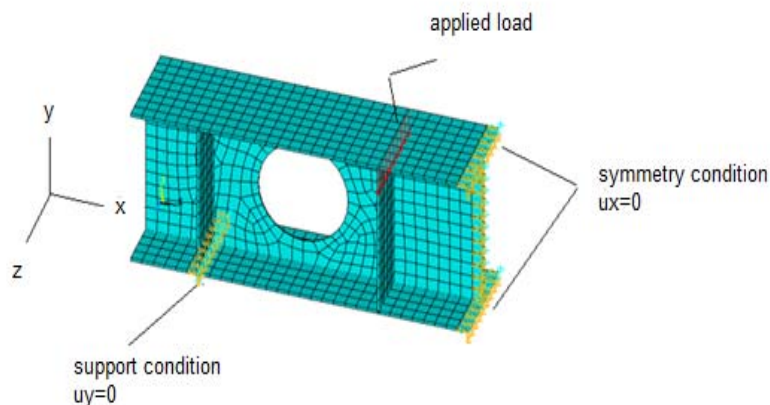

Figure (4): Typical finite element mesh, boundary conditions and applied load.

Results and discussion

The load on beams was applied monotonically in increments. The maximum load recorded by the testing machine was considered as the ultimate load. A summary of experimental and finite element results of beams is presented in Table (3). Figure (5) shows the specimens after failure and Figure (6) represents the load-deflection plot from the finite element analysis and the experimental results for all beams.

Table (3): Experimental and finite element results of tested girders.

Series	Girders	Experimental ultimate load P_{ult} (kN)	P_{uo}/P_{us}	Analytical ultimate load P_{FE} (kN)	P_{FE} / P_{ult}
Control	BO	130	----	140	1.07
A	BC1	105	0.8	110	1.04
	BC2	70	0.54	80	1.09
	BC3	40	0.31	44	1.08
B	BS1	100	0.77	107	1.07
	BS2	60	0.46	63	1.04
	BS3	30	0.23	33	1.09

- P_{us} is the ultimate load of the solid web girder.
- P_{uo} is the ultimate load of girders with opening web.

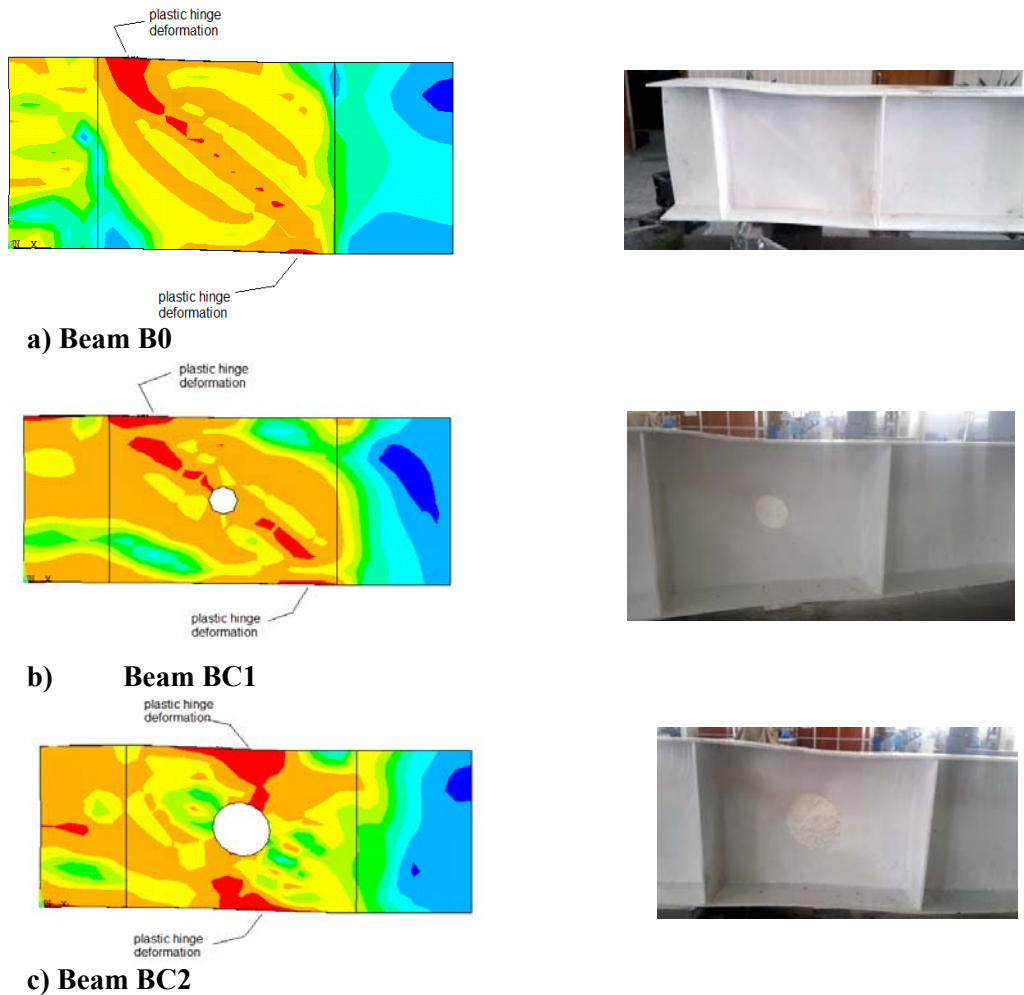
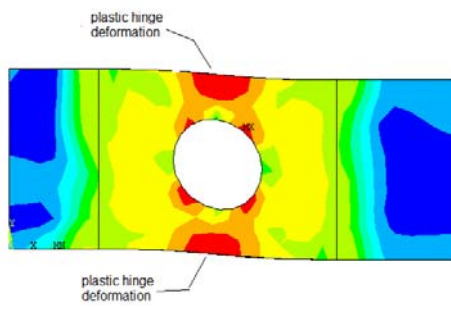
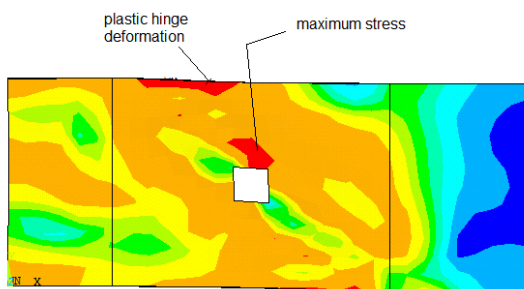

Figure (5): Specimens after failure (theoretically by FEM and experimentally)



d) Beam BC3



e) Beam BS1

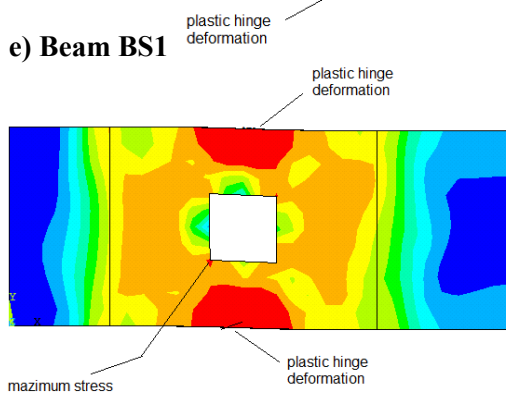

f) Beam BS2

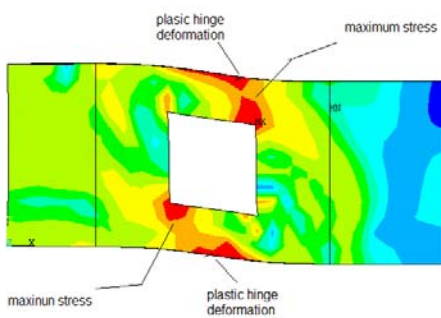

g) Beam BS3

Figure (5): Continued

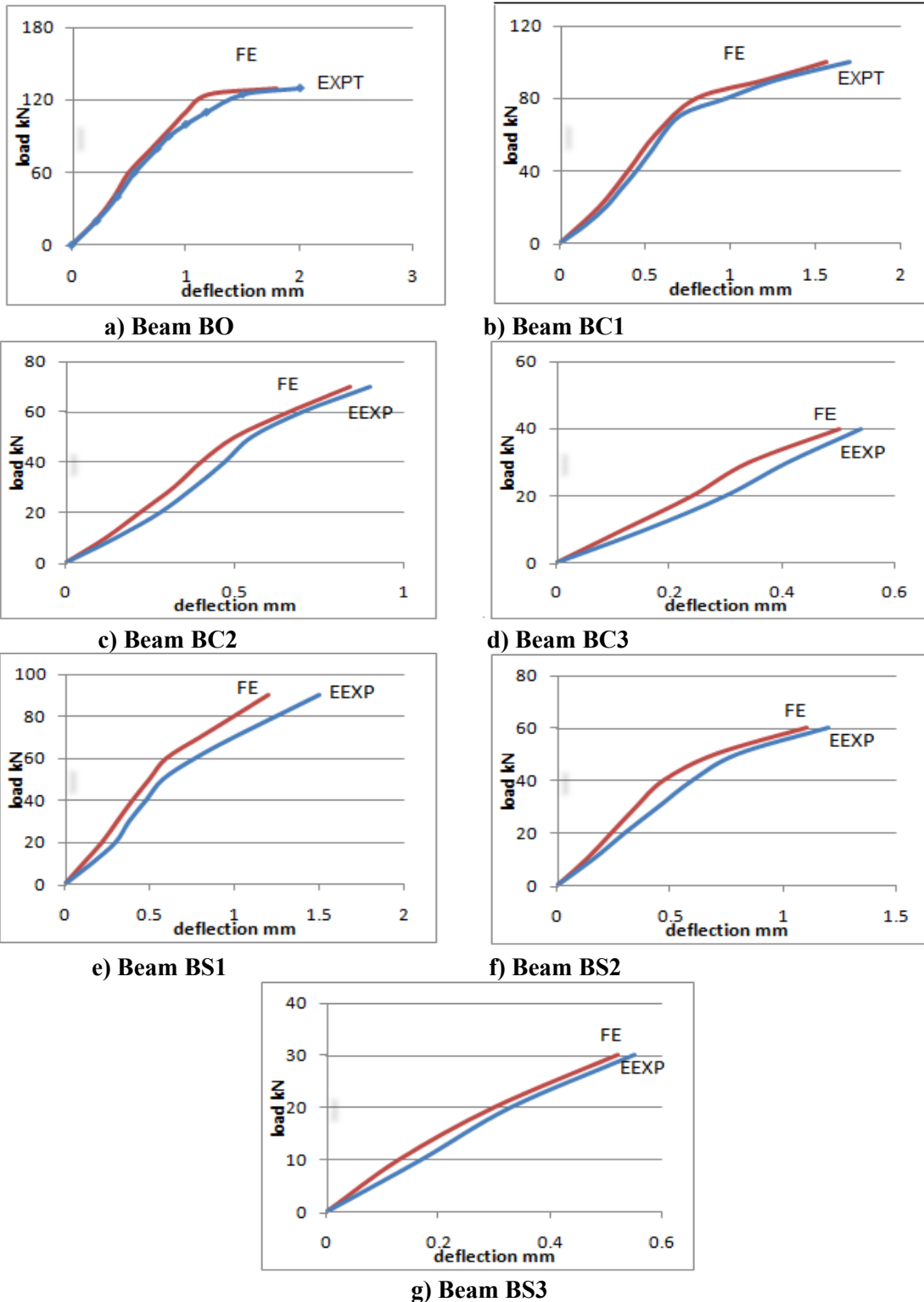

Figure (6): Variation of deflection with load for all beams.

From the comparison between the experimental and finite element results in Table (3) and from noticing Figures (5) and (6), it is obvious that the finite element modeling is able to predict the buckling and ultimate load with sufficient accuracy.

From the failure mode of the solid web girder, Figure (5-a), and girders with small web opening ($d_o=50$ mm), both circular (Figure (5-b)) and square (Figure (5-e)), we can noticed that the failure occurred approximately along the diagonal of the web and the maximum stress located along the diagonal of buckling. The plastic hinge formed at a point close to the interaction line between the web and the flanges. Figure (7) represents the direction of shear failure of these girders.

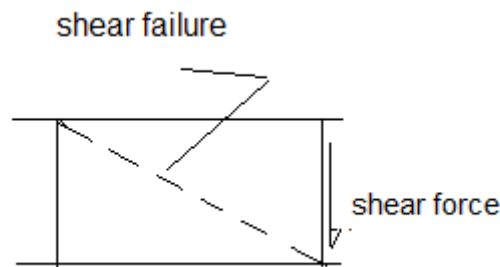

Figure (7): Failure for solid and small web opening ($d_o=50$ mm) girders

Also, from noticing the failure mode of girders with large circular and square web opening ($d_o=100$ and 150 mm), Figure (5-c,d,f,and g), we can noticed that the shear failure occurred at approximately a 45 degree angle through the hole, as schematically shown in Figure (8). The plastic hinge formed close to the vertical center line of the web. This means that the hinge location is related to the size of hole in the web.

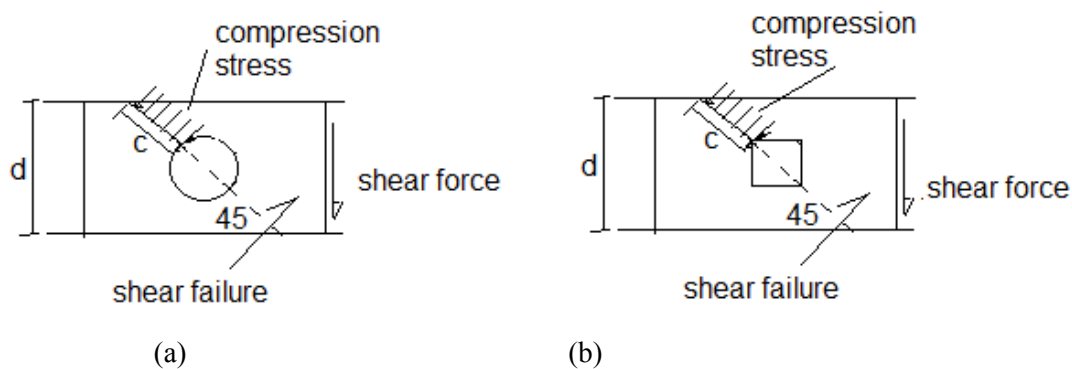

Figure (8): Resulting compression force due to shear of opening web; a) circular web opening and b) square web opening.

For the web with square hole it can be noted that, in addition to stress concentration above and below the hole, the stress also concerted at edges of the opening. Therefore, the corners of square openings should be curved in order to minimize or to eliminate as can as possible the stress concentration.

The results of Table (3) indicate that the presence of opening in the web leads to decrease the ultimate load and the ultimate load decreases as the size of opening increases. The reason behind this may be that the presence of the opening reduces the c value (c represents the zone length which exposed to compression stress as indicated in Figure (8)). This reduces the strength of web against the buckling and the beam will fail early.

The experimental results of the ultimate load were plotted versus the mid span deflection for selected girders. Figure (9) shows the load - deflection curves for girders BO, BC2, and BS2.

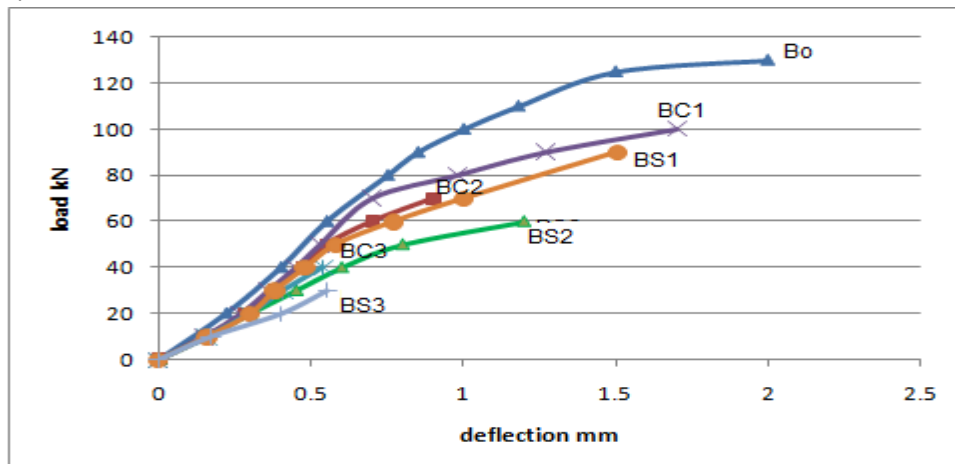

Figure (9): Load-deflection curves of BO, BC2, and BS2

From this figure, the load-deflection curves for all girders remain linear until the critical buckling load occurs, after this stage, post buckling stage starts. At this stage, the curve of the beam BO behaves nonlinearly, and the load increases by forming the tension field at web panel. The panel reaches its ultimate failure load by forming plastic hinges at top and bottom flanges. Also, beam BC2 has a curve of nonlinear behavior after the critical buckling load. At the stage of post buckling, the tension field action cannot develop adequately as a result of the large removed area from the web. Thus, the ultimate load of beam BC2 is less than that of beam BO. Behavior of BS2 is similar to that of beam BC2, but with smaller ultimate load. The load-deflection curve of this beam is linear up to initial buckling, then the web panel develops a tension field action worse than beam BC2 due to the stress concentration at edges of the square opening which leads to buckle the web early and forming final collapse of the panel.

Parametric study

A parametric study on plate girders with web containing central circular holes was carried out using the proposed finite element models. Same material properties were employed for all models. The parameters considered in this study included web slenderness ratio (d/t_w) and flange stiffness (width of flange to its thickness b_f/t_f). The influence of web slenderness ratio (d/t_w) on the ultimate load carrying capacity of plate girders (solid and containing central circular holes) was studied by analyzing ten girders; five girders are of solid web and the other five girders are containing circular holes ($d_o= 150$ mm). The ultimate loads of the studied models are given in Table (4).

Table (4): Effect of web slenderness ratio on ultimate loads

t_w (mm)	d/t_w	Ultimate load of girders with solid web P_{us} (kN)	Ultimate load of girders with opening web P_{uo} (kN)	P_{uo}/P_{us}
3	100	195	121	0.62
2.5	120	150	87	0.58
2	150	130	70	0.54
1.5	200	110	48	0.43
1	300	90	36	0.40

From Table (4), It can be noticed that, as the web slenderness ratio (d/t_w) increases the ultimate load decreases. Increasing (d/t_w) from 100 to 300 will decreasing the ultimate load of the solid web girder from 195 to 90 kN (a reduction of 54%) and will decreasing the ultimate load of the girder with circular opening web from 121 to 36 kN (a reduction of 70%). Thus, girders with web opening are more sensitive to the changing in the web slenderness ratio than those with solid web.

The influence of flange stiffness (b_f/t_f) on the ultimate load carrying capacity of plate girders (solid and containing central circular holes) was studied by analyzing ten girders; five girders are of solid web and the other five girders are containing circular holes ($d_o= 150$ mm). All girders have (d/t_w) = 175. The ultimate loads of the studied models are given in Table (5).

Table (5): Effect of flange Stiffness on ultimate loads

t_f (mm)	b_f/t_f	Ultimate load of girders with solid web P_{us} (kN)	Ultimate load of girders with opening web P_{uo} (kN)	P_{uo}/P_{us}
8	25	160	93	0.58
6	33.33	130	70	0.54
4	50	112	57	0.51
2	100	100	50	0.50

• b_f is the wide of flange • t_f is the thickness of flange

From Table (5), It can be noticed that, as the flange stiffness (b_f/t_f) increases the ultimate load decreases. Increasing (b_f/t_f) from 25 to 100 will decreasing the ultimate load of the solid web girder from 160 to 100 kN (a reduction of 38%) and will decreasing the ultimate load of the girder with circular opening web from 93 to 50 kN (a reduction of 46%). Thus, girders with opening webs are slightly more sensitive to the changing in the web slenderness ratio than those with solid web. However, the ultimate load capacity is less sensitive to the variation of the flange stiffness ratio than that of the web slenderness ratio. This may be due to the fact that the contribution by flanges to resist the load is small compared to that of the web.

CONCLUSIONS

The following conclusions can be drawn from this investigation:

1. Buckling failure of solid web girders and girders with small circular and square web openings ($d_o=50$ mm) is along the diagonal of the web and the plastic hinge formed at a point close to the interaction line between the web and the flange. While girders with large circular and square web opening ($d_o=100$ and 150 mm) the shear failure occurs at approximately a 45 degree angle through the hole and the plastic hinge forms close to the vertical center line of the web.
2. The presence of openings in the web and the size of these openings lead to decreasing ultimate load capacity.
3. Stresses are concentrated at edges of square web openings. Thus the corners of these openings must be curved in order to minimize or to eliminate stress concentration.
4. As the web slenderness and flange stiffness ratios increase, the ultimate load decreases. However, the ultimate load capacity is less sensitive to the variation of the flange stiffness ratio than that of the web slenderness ratio.
5. Girders with web opening are more sensitive to the changing in the web slenderness and flange stiffness ratios than those with solid web.

REFERENCES

- [1]. Salmon, C.G., Johnson, J.E., and Malhas, F.A., "Steel Structures Design and Behavior", Fifth Addition, Parson International Edition, New Jersey.(2009)
- [2]. McCormac, J., "Structural Steel Design", Fourth Edition, Pearson Education International, London, (2005).
- [3]. Narayanan, R, and Rockey, K. C., "Ultimate Capacity of Plate Girders with Webs Containing Circular Cutouts", Proceedings, Institution of Civil Engineers, London. Part 2, 2, 845-62, (1979).
- [4]. Rockey, K. C, Evans, H. R. and Tany K. H., "An Investigation of the Rigidity of Longitudinal Web Stiffeners for Plate Girders", University Cardiff, Report, (1979).
- [5]. ISSN : 2248-9622, "Analysis of Steel Beam with Web Openings Subjected to Buckling Load", Vol. 4, Issue 5(Version 2), May, pp.185-188, (2014).
- [6]. Hoglund, T. (1971), "Shear Buckling of Steel and Aluminum Plate Girders", Journal of Structural Engineering, The Royal Institute of Technology, Stockholm, Sweden, (1971).
- [7]. Baranda, H., Daly, M. J. and Redwood, R. G, "Tests of Thin-webbed Beams with Unreinforced Holes", ASCE Journal of the Structural Division, Vol. 104, pp. 577 – 595, (1978).
- [8]. Redwood, R.G. and Shrivastava, S.C., "Design Recommendations for Steel Beams with Web Holes", Canadian Journal of Civil Engineering, Vol. 7, pp. 642 – 650, (1980).
- [9]. Narayanan, R, Der Avanesian, NGV, "An Equilibrium Method for Assessing the Strength of Plate Girders with Reinforced Web Openings", Proc. Inst. Civ. Eng., 77(2), 107-37, (1984).
- [10]. Hamoodi, M.J. and Hadi, W.K., "Tests of Composite Beams with Web Openings", Eng. and Tech. Journal, Vol. 29, No.10, (2011).
- [11]. Hamoodi, M.J. and Abdul Gabar, M.S., "Behaviour of steel plate Girders with Web Opening Loaded in Shear", Eng. and Tech. Journal, Vol. 31, Part (A), No. 15, (2013).
- [12]. ASTM A 370-05, "Standard Test Method and Definition for Mechanical Testing of Steel Products", Annual Book of ASTM Standard, Vol. 01.01. ASTM, Philadelphia, PA. 2005.
- [13]. ANSYS, "ANSYS Help", Release 12.0, USA, Copyright 2006 Edition, John Wiley and Sons New York, (1981).