

PAPER • OPEN ACCESS

Investigation of Torsion behavior of high strength short fiber reinforced concrete deep beams with openings

To cite this article: M A Ahmmed *et al* 2020 *IOP Conf. Ser.: Mater. Sci. Eng.* **888** 012021

View the [article online](#) for updates and enhancements.



LIVE AWARDS AND SPECIAL EVENTS

PLENARY LECTURE:
"Perovskite Solar Cells: Past 10 Years and Next 10 Years" with *Nam-Gyu Park*

LEGENDS OF BATTERY SCIENCE:
A Celebration with *M. Stanley Whittingham* and *Akira Yoshino*

PRiME 2020 • October 4-9, 2020
Hosted daily: 2000h ET & 0900h JST/KST

PRIME™
PACIFIC RIM MEETING
ON ELECTROCHEMICAL
AND SOLID STATE SCIENCE
2020

**ATTENDEES
REGISTER FOR FREE ▶**

The banner features several logos and portraits: a green 'e' logo, a circular portrait of Nam-Gyu Park, a circular portrait of M. Stanley Whittingham, a circular portrait of Akira Yoshino, and the Electrochemical Society logo.

Investigation of Torsion behavior of high strength short fiber reinforced concrete deep beams with openings

M A Ahmmed¹, A H Chkheiw², and J A Kadim³

^{1, 2, 3} Civil Eng. Department, Engineering College, University of Basrah, Basra, Iraq

*Corresponding author: jafaarahmed@yahoo.com

Abstract. This study aims is to investigating the structural capacity of fibbers reinforced deep beams with opening under pure torsion. The deep beams were made of high strength concrete. The openings were made in the web with different shapes (circular and square), sizes and located at the mid span. Seventeen deep beam specimens were casted and they experimentally investigated throughout this study. The constants in this study are beam dimensions and compressive strength for concrete. The effects of the shape, size and locations of opening on the torsional behaviour of deep beams under torsional loading are studied in the paper. The results showed the square opening is weakest due to the concentration effect which increases the stresses and the opening size participate main role in strength of deep without steel fiber. Also, the steel fibre in which the presence of steel fiber causes increasing in the torsion strength about (30-32) of tested specimens.

1. Introduction

For many years, torsion in reinforced concrete structures was regarded as a less important effect and it was not considered clearly in the analysis and design so that its influence was included in the factor of safety instead conventionally structures designed. Present analysis methods and design have resulted in less conservation leading to sensible lesser members size so that these members must be strengthened. Many modern structures require to increasing the torsional strength, as the torsional strength become the vital aspect of structural behavior, such as the curved bridge girders, an eccentrically loaded box beams, and the helical stairway slabs [1].

Alnuaimi et al. [2] investigated the results of 14 tested reinforced concrete beams which divided into seven hollow and seven beams. The 14 beams were designed (as hollow sections) to resist combined load of shear, bending, and torsion. The beams cross-section was (300× 300) mm and its length 3,800 mm. For the hollow beams, the internal hollow core dimensions was (200× 200) mm making a thickness of peripheral wall 50 mm. Two main parameters studied were in which the first was the ratio of bending to torsion which varied between 0.19 and 2.62 and the second was the shear stress in the web ratio due to shear stress of torsion to shear stress due to shear force which was changed from 0.59 to 6.84. The results showed that the concrete core participates the beams strength behavior and cannot be ignored when collective load of shear, bending, and torsion was there. All hollow beams cracked and failed at smaller loads than their counterpart solid beams. The lesser ratio of torsion to bending gave the big differences in failure loads between the solid and hollow beams. The transverse steel experienced lower strain values while longitudinal steel yielded.

Bernardo at el., [3] studied the ultimate torsional behavior of hollow beams cast from high-strength concrete according to their strength and ductility. Sixteen beams were tested which had a square cross section and with symmetrically distribution reinforcement. The study parameters included the



Content from this work may be used under the terms of the [Creative Commons Attribution 3.0 licence](https://creativecommons.org/licenses/by/3.0/). Any further distribution of this work must maintain attribution to the author(s) and the title of the work, journal citation and DOI.

compressive strength of concrete (from 46.2 to 96.7 MPa) and the torsional reinforcement amount (from 0.30 to 2.68%). The study indicated that the torsional ductility was low in which the reinforcement ratio range where the ductility was still occurred in very narrow variety. Various codes of practice such as Norwegian, Canadian, New Zealand, European and ACI Codes were compared depending on the experimental results. Consequently, they found that the ACI Code was mostly closer in predicting the torsional strength in addition to preventive torsion reinforcement so that they leading to a appropriate ductile behavior.

Abdul-Hussein, [4] investigated the torsional capability of reinforced concrete beams as a function of different parameters such as the fibers amount (with and without openings) and the reinforcement ratio in each direction. The fifteen tested beams have different steel fibers that range from zero up to one percent. Tested specimens were analyzed with finite elements approach "FEA" by finite element software ANSYS with good results when compared with experimental tests results. The results showed that adding one percent of steel fiber increased the ultimate torque and reduced cracking by significant amount. An increase of forty three and sixty six percent in cracking torque and fifty eight and fifty four percent in ultimate torque for solid and hollow section respectively has been achieved, as longitudinal and transverse reinforcement ratios two percent were kept constant.

Barghlame at el., [5] investigated the torsion capacity of ultimate point on rectangular beams with spiral reinforcements in the torsion direction and its anti-direction. The beams models had been numerically analyzed under different loads using ANSYS software. It was found that the spirally reinforced prismatic beam in addition to beam with spiral links show lesser torsional capacity compared to beam with tied links.

Mahdi [6] studied the torsional behavior of hollow 6 beams cast with high strength self-compacted concrete under pure torsion. The same cross section, the same length, the same concrete mixture, and quality control were used for all beams. Beams had an external dimensions (300x300 mm) and hollow dimensions (180 x180 mm) and all the beams had the same number of main reinforcement 4-12 mm diameter at the top and the bottom. The stirrups spacing was the main variable to investigating the stirrups amount effect on enhancing the hollow beam resistance adjacent to torsional moments. Results showed that, by decreasing the stirrups spacing, many structural beams properties were improved. The peak improvement was related to the ultimate torsional moment (T_u), cracking torsional moment (T_{cr}), angle of twist (ϕ), and finally concrete strain (ϵ).

2. Research Significance

This study aim to investigate the structural capacity of fiber reinforced concrete rectangular deep beams with opening under pure torsion. The beams were made of high strength concrete. The openings were made in the web with different shapes (circular and square), and sizes which located at the mid span. Nineteen deep beams were experimentally investigated through this study. The constants in this study are beam dimensions and compressive strength for concrete. The effects of the shape, size, and locations of opening on the torsional behaviour of deep beams under torsional loading are studied in this research.

3. Experimental Program

In this study seventeen specimens were tested in order to investigate the effect of maximum size of opening and it shape on deep beam also investigate the steel fiber effect on torsion strength of deep beam. The work was separated into two groups, in the first group, nine specimens were tested with maximum opening size and different shape to investigate which shape of opening has good stress distribution and more torsion strength. After determine the optimum shape of opening (circle shape), eight specimens tested as second stage.

3.1. Description of specimens

All specimens have size 350x100 mm and clear span equal to 1000 mm and all specimen satisfy the ACI 318-19 [11] section 9.9.1.1.a. Detail of the specimens can be shown in table 1 and in the figures 1 to 3.

Table 1. Detail of the tested specimens.

| Group | No. | Symbol | Description of Opening, cm | Steel Fibre, % |
|-------|-----|---------|----------------------------|----------------|
| one | B1 | Control | Without | Without |
| | B2 | D1S0 | Square 13x13 | Without |
| | B3 | D1S50 | Square 13x13 | 0.50 |
| | B4 | D1S1.0 | Square 13x13 | 1.00 |
| | B5 | D1S 1.5 | Square 13x13 | 1.50 |
| | B6 | D1C0 | Circle Diameter=15 | without |
| | B7 | D1C 0.5 | Circle Diameter=15 | 0.50 |
| | B8 | D1C1.0 | Circle Diameter=15 | 1.00 |
| | B9 | D1C1.5 | Circle Diameter=15 | 1.50 |
| Two | B11 | D2C0 | Circle Diameter=12 | Without |
| | B12 | D2C0.5 | Circle Diameter=12 | 0.50 |
| | B13 | D2C1.0 | Circle Diameter=12 | 1.00 |
| | B14 | D2C1.5 | Circle Diameter=12 | 1.50 |
| | B15 | D3C0 | Circle Diameter=9 | Without |
| | B16 | D3C0.5 | Circle Diameter=9 | 0.50 |
| | B17 | D3C1.0 | Circle Diameter=9 | 1.00 |
| | B18 | D3C1.5 | Circle Diameter=9 | 1.50 |

3.2. Materials

In casting all beam specimen the following material properties were used as follows:

3.2.1. Cement. Ordinary Portland cement was used in this study, which comply with Iraq Standard Specification I.Q.S. No.5, (1984) [7] requirements.

3.2.2. Aggregate. The used fine aggregate is natural sand from Al-Zubair region. The fine aggregate satisfies the limits of the Iraqi specification I.Q.S. No.45 (1984) [8] while the coarse aggregate is a gravel has maximum size of 10 mm from Al-Zubair region. The coarse aggregate conforms to the Iraqi specification I.Q.S. No.45 (1984).

3.2.3. Superplasticizer. Superplasticizer HWRA (high water reducing agent) based on polycarboxylic-ether is used to production high strength concrete. One of a new generation of copolymer-based superplasticizer is the Glenium 51. It complies with type A and type F of ASTM C494 (2004) [9].

3.2.4. Silica Fume. Silica fume is used as a mineral admixture which added in order to obtain the high strength concrete mixes of this study. The percentage used was 10%, as partial replacement of cement weight.

3.2.5. Steel Fibres. Hooked type high tensile steel fibers was used with different volume fractions of (0, 0.5, 1.0, and 1.5%). The properties of the used steel is shown in table 2.

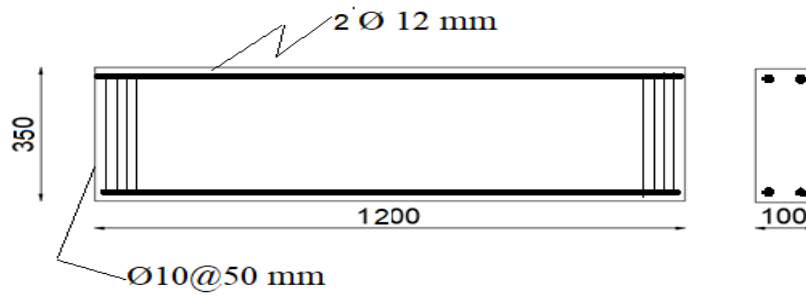

Figure 1. Detail of control beam.

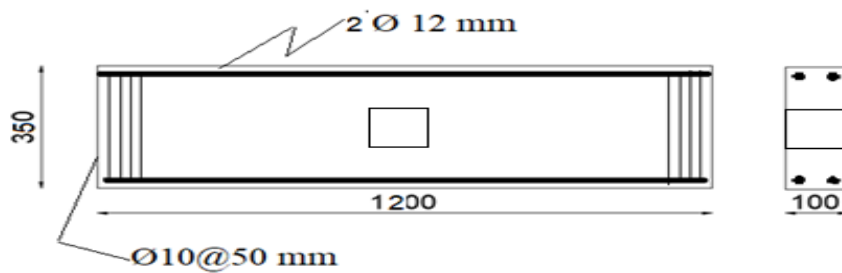

Figure 2. Detail of beam with rectangle opening.

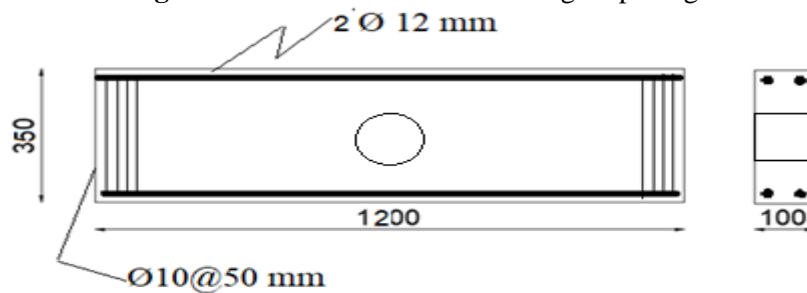

Figure 3. Detail of beam with circle opening.

Table 2. Properties of steel fibers.

| Property | Specifications |
|----------------------------|-------------------------|
| Density | 7860 kg/m ³ |
| Ultimate strength | 2000 MPa |
| Modulus of Elasticity | 200x10 ³ MPa |
| Strain at proportion limit | 5650 x10 ⁻⁶ |
| Poisson's ratio | 0.28 |
| Average length | 30 mm |
| Nominal diameter | 0.375 mm |
| Aspect ratio (Lf/Df) | 80 |

3.2.6. Steel Reinforcement. 10 mm diameter steel bars was used as flexural reinforcement which placed in the tension face of the beam with spacing of 175 mm. The yield strength was found from tensile test and its value equals to 490 N/mm² and the ultimate strength was 685 N/mm² noting that steel reinforcement complies with ASTM A615/A615M – 16 [10].

3.2.7. *Water.* For casting and curing of concrete, ordinary potable water was used.

3.3. *Mixing Processes of concrete*

Table 3 shows the proportions with all properties of high strength concrete mixes are used in this study depending on steel fiber fraction (0, 0.5, 1.0, and 1.5%) by volume of concrete.

Table 3. Mix proportions of all the used mixes specimen.

| Mix | | Ref | 0.5 %SF | 1.0% SF | 1.5% |
|----------------------------------|--------------------|------|---------|---------|-------|
| Mix proportion | Unit | | | | |
| Cement | Kg/m ³ | 500 | 497 | 495 | 493 |
| Sand | Kg/ m ³ | 677 | 674 | 670 | 667 |
| Gravel | Kg/ m ³ | 1015 | 1010 | 1005 | 1000 |
| Silica fume | Kg/ m ³ | 50 | 49.7 | 49.5 | 49.3 |
| Water | Kg/ m ³ | 150 | 149 | 148.5 | 148 |
| Superplasticizer | Kg/ m ³ | 7.0 | 7.5 | 8.0 | 8.3 |
| Steel fiber | Kg/ m ³ | 0 | 39.2 | 78.5 | 117.7 |
| W/cm | | 0.28 | 0.28 | 0.28 | 0.28 |
| Steel fiber fraction (by volume) | % | 0.0 | 0.5 | 1.0 | 1.5 |
| Properties of fresh concrete | | | | | |
| slump | mm | 150 | 150 | 150 | 145 |
| Properties of Hardened concrete | | | | | |
| Compressive strength | MPa | 85.4 | 88.0 | 91.0 | 93.5 |
| Flexural strength | MPa | 7.4 | 9.0 | 11.5 | 13.4 |

3.4. *Specimen preparation*

All moulds were prepared by cleaning their internal surfaces and they oiled to avoid adhesion to concrete later than hardening and the reinforcement details and the wooden moulds are shown in figure 4. The preparation and mixing procedure of specimen was carried as follows:

- The concrete cover outside the stirrups was ensured by placing concrete spacers between the stirrups and the steel mould. The mould was oiled one day before casting.
- All quantities were weighted and packed in a clean container before mixing.
- Steel bars (Longitudinal and stirrups) were placed in their accurate positions and the specified protection cover was checked.

For reference concrete, the cement and silica fume were mixed in dry state for concerning 2 minutes to scatter the silica fume particles all through the cement particle, then the sand was added so items were mixed continued for another 2 minutes. Then, the necessity quantity of water was added in which whole mixture were mixed for 2 minutes.

The superplasticizer was dissolved in water and the water and superplasticizer solution was added gradually through the mixing process, next the whole mixture was mixed for 7 minutes. Approximate total mixing time was 13 minutes. After hat, concrete was poured in the moulds in three layers for which each layer was compacted using handle electrical vibrator of (3000 vibrations per minute) for 30 seconds.

The upper surface of concrete was smoothly finished half-hour after casting was completed using a hand trowel. All specimens were left in the laboratory for 24 hours, later they were demoulded and then treated with tap water for 28 days.



Figure 4. The reinforcement details and the wooden moulds.

3.5. Test set up, loading procedure and instrumentation

All beams had tested using the Universal Testing Machine model (8551 MFL system) as shown in figure 5 with a maximum capacity of 300 tons. The beams are placed in the machine on free supported rollers at each end with clear span of 650mm. Two steel I sections stiffened by a tapered plate that act as lever arms were attached to the concrete beam and they are capable of given that a maximum eccentricity of 600mm with respect to the longitudinal axis of the beam. Threaded rods (anchored to the machine frame) was used to support the reaction. A steel box (made from two channel sections) girder is laid down diagonally resting on hinged end supports on top of the lever arms. The box section girder was loaded at its mid-span.

To avoid any axial restraints, two spherical seats were fashioned for the end supports of the beam specimen. They were free to move longitudinally to allow for beam elongation and allow the beam to twist freely under the applied torque. The equipment and other accessories for the manufacturing and testing arrangement of the tested beams are all available in the University of Basrah / Engineering College of Construction laboratories and Researches.

3.5.1. Instrumentation. At every stage of loading during testing, the main characteristics of the structural behavior of the tested beam are detected for both the first cracking torque and the ultimate torque and the devices of measurements for each instrument are presented in table 4. The measurements, which were recorded during the tests, are the following:

Lateral (vertical) displacements at specimen ends due to rotation.

The lateral displacement is measured using LVDTs (Linear Variable Differentiable Transformers).

Relative rotation of the beam is determined with the help of two LVDTs (No. 1 and 2). The measurements obtained for the load arms by measuring the vertical displacements to calculate the rotations at each end of the specimen. The relative rotation between the two ends is used to determine the angle of twist of the beam.

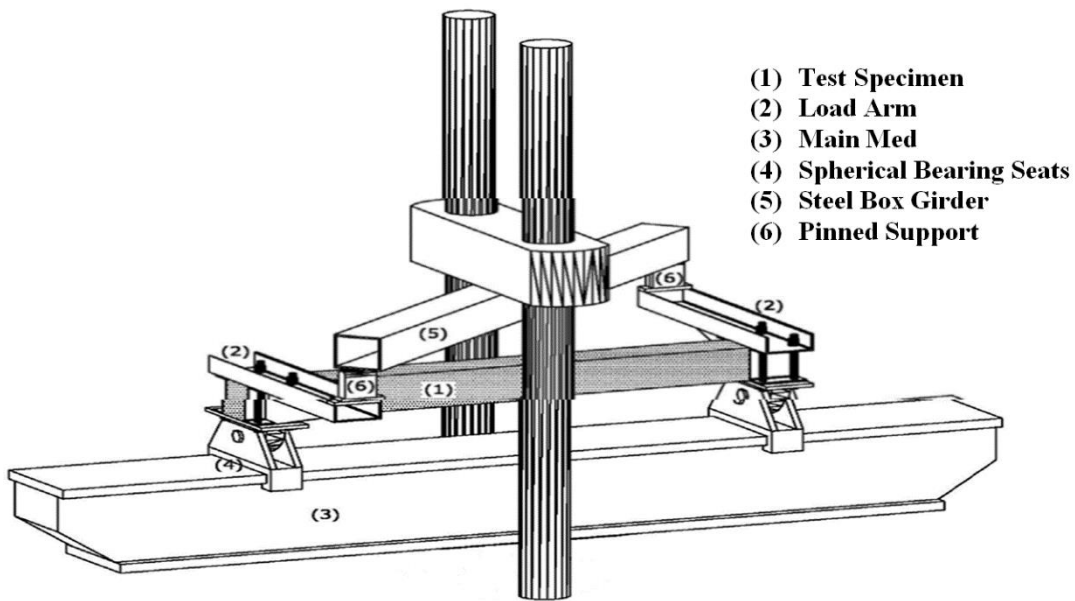

Figure 5. Schematic Diagram of Universal Testing Machine.

Table 4. Instrumentation details.

| Device | Measurement | Purpose |
|-----------|-----------------------|--|
| LVDTs 1,2 | Vertical Displacement | To record the angle of twist of the beam |

3.5.2. *Testing Procedure.* The beams have been painted by white spray paint before testing. The test setup and instrumentation used for the tested specimens are shown in figure 6. All specimens were tested under monotonically increasing torque until reaching to failure stage. A trial test was performed previous to test the beams in which the beam was loaded up to failure. The recorded data were analyzed to make sure adequate working conditions of all the instrumentation used. After performing the trial test, the actual tests were gradually applied. For each load increment, the readings were acquired manually and the torque was increased gradually up to failure of the beam.



Figure 6. Test setup and instrumentation used.

4. Test Results

All tested beams failed suddenly after reaches to ultimate torque strength, with forming compression hinge at lateral side of the beam.

4.1. Effect of shape opening

Nine specimens have been tested with different opening shape; circle and square opening which have equivalent size with circle opening, the center of opening located at center of beam, the results of ultimate torque for the tested specimens are tabulated in table 5. The results show that the ultimate torque of deep beam with square opening is less than the ultimate torque of control deep beam, that has ultimate torque (102 kN.m for beam without opening) by (56%) in case of without steel fiber and this decreasing percentage will be decrease into (39%) in case of square opening steel fiber (0.5 %) and become (26%) in case of square opening steel fiber (1.0 %) and (24%) in case of square opening steel fiber (1.5 %), through observation of decreasing ratio that special of deep beam with maximum size square opening that notice the decreasing ratio decreasing with increase steel fiber ratio that is explain the effect of steel fiber to make deep beam stiff and increasing of ultimate torque by resisting tensile forces that is found due to compression path and it make bridge to eliminate of cracks and this confirm of importance of steel fiber.

In the same table 5, the results of deep beam with maximum size circle opening show that the decreasing ratio of strength in case of without steel fiber is (46%) as compare of control deep beam at the same time this ratio is less than the ratio (56 %) in case of square opening, at other side if the comparison made between decreasing ratio of deep beam with circle opening in case of steel fiber (1.5 %) that has decreasing ratio (15%) which is less than decreasing ratio in case of square opening (24%), after comparison the efficiency of opening shape is clear against steel fiber ratio and efficiency of circle opening is more than square opening to transmitted torque so that the perfect opening shape is circle opening that give more strength.

Figure 7 represents typical relation between the angle of twist and torsional moment of the tested specimens. The ability of circle opening to transmit the load that give more strength all that will be give more stiff than square opening and the evidence on that the angle of twist of the specimens in case of circle opening are less than the specimens in case of square opening.

It is observed that square opening is weakest because of sharp corners that are concentrated by stress, and the twisting of solid beam is lower than other and the beams with square opening are higher twisting response comparison with other specimens. That is mean that solid beam is higher stiffness than other.

Table 5. Experimental results at ultimate torsion instrumentation.

| series | No. | Description of Opening (cm) | Angle of Twist Degree/ meter | Ultimate Twist (kN.m) | Decrease in Tcr. % of B1 |
|--------|-----|-----------------------------|------------------------------|-----------------------|--------------------------|
| | B1 | Without | 0.50 | 102 | --- |
| | B2 | Square 13x13 | 0.43 | 45 | 56 |
| | B3 | Square 13x13 | 0.28 | 62 | 39 |
| | B4 | Square 13x13 | --- | 75 | 26 |
| One | B5 | Square 13x13 | --- | 78 | 24 |
| | B6 | Circle Diameter=15 | 0.37 | 55 | 46 |
| | B7 | Circle Diameter=15 | 0.38 | 79 | 23 |
| | B8 | Circle Diameter=15 | --- | 82 | 20 |
| | B9 | Circle Diameter=15 | --- | 87 | 15 |

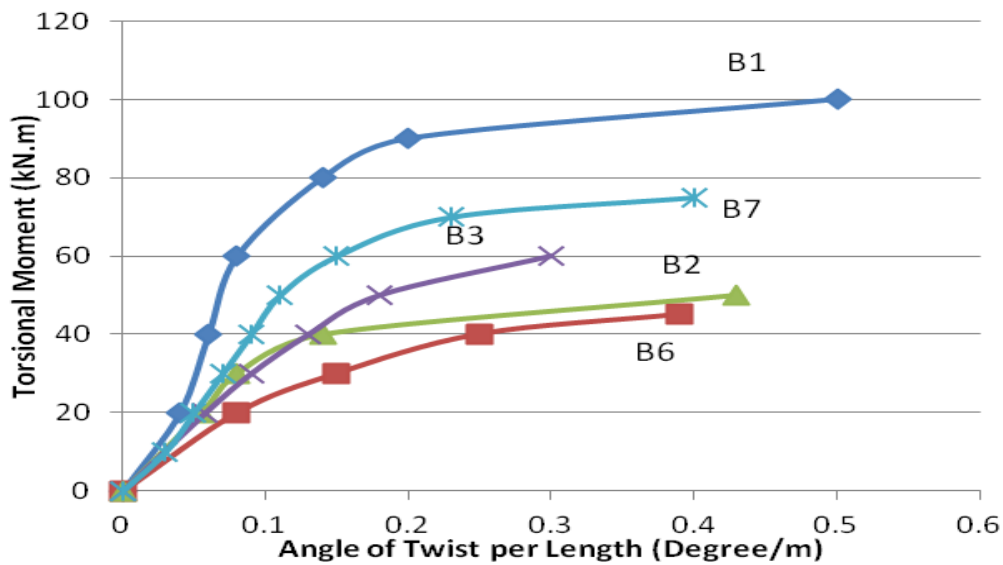

Figure 7. Torsion-Angle of Twist Relation (First Group).

4.2. Effect of size opening

After confirm the shape of opening is circle a result of second group specimens tabulated in table 6 to make a comparison between deep beams with two types of circle opening size against steel fiber ratio to select optimum opening size, and the relation between deflection and angle of twisting are shown in figure 8.

Through observation of data tabulated the results show that the specimen (B11) that has circle opening size (12 cm dia.) without steel fiber has decreasing ratio (40%) than control deep beam while the other specimen (B15), that has circle opening size (9 cm dia.) without steel fiber, has decreasing ratio (35%) than control deep beam at the same time this decreasing ratio is more than the decreasing ratio in case of (B11). When the steel fiber ratio up to (0.5%) that will make a difference that's notice in specimen (B12) that has circle opening size (12 cm dia.) which has decreasing ratio (29%) than control deep beam that differ than the specimen (B16) that has circle opening size (9 cm dia.) which has decreasing ratio (22%) than control deep beam, also if the steel fiber increase to (1.0%) the strength of specimen (B13) with be decreasing by (18%) than control deep beam while the specimen (B17), that has circle opening size (9 cm dia.), has increasing ratio (10%) than control deep beam, at now if a comparison made between six specimen which it results have been showed to notice the affectivity of circle opening size (10cm dia.) that give more strength with varied the steel fiber ratio. The little difference between both case with steel fiber ratio (1.5%) explain the changing on behavior of deep beam by increasing the steel fiber up to (1 %) and probably the little difference in both case will be vanished if increase steel fiber up to (1.25% or 1.5), and for the practical requirements in engineering services that favorite larger opening size to cross as possible as services through it also for economical requirements in case of huge structure that save more quantity of concrete if used larger opening, so that apply to the requirements mentioned previously, in the research will be uses optimum circle opening size is (12 cm dia.) with steel fiber ratio (1.5%) instead of opening (9 cm dia.)

Through the results, the opening size is play main role in strength of deep without steel fiber, when the circle opening is maximum size (15 cm dia.) the strength is drop into (54 %) because the size of opening that cut off shear zone so that the interrupt the compression path so that the little compression stress is crossing to compression path also the location of opening at the center the beam make the effect significant, and when the opening size is decrease the strength is decrease and become (35%) when the opening size is (9 cm dia.) so that more compression stress as possible as crossing through the compression path.

Also the angle of twisting in case of circle opening size (9cm da.) are less than the angle of twisting in case of circle opening size (12 cm dia.) the reasons that give specimens with circle opening size affectivity is the opening, that located at shear centre at the same time it interrupt compression path, has smaller size that permit more compression stress to follow through the remaining shear zone. It can be noticed that increasing in opening size decreases the ultimate torsional capacity this reduction is due to the reduction in web area of the beam. Also notice that failure lines passing within opening of beams are due to the presence of openings which decrease.

Table 6. Effect of size of opening.

| series | No. | Opening Diameter (cm) | Steel Fiber (%) | Ultimate Torque (kN.m) | Decreasing in Torque (%) |
|--------|-----|-----------------------|-----------------|------------------------|--------------------------|
| | B1 | Without | Without | 102 | --- |
| | B11 | 12 | Without | 61 | 40 |
| | B12 | 12 | 0.50 | 72 | 29 |
| | B13 | 12 | 0.75 | 84 | 18 |
| B | B14 | 12 | 1.00 | 93 | 9 |
| | B15 | 9 | without | 66 | 35 |
| | B16 | 9 | 0.50 | 80 | 22 |
| | B17 | 9 | 0.75 | 92 | 10 |
| | B18 | 9 | 1.00 | 97 | 5 |

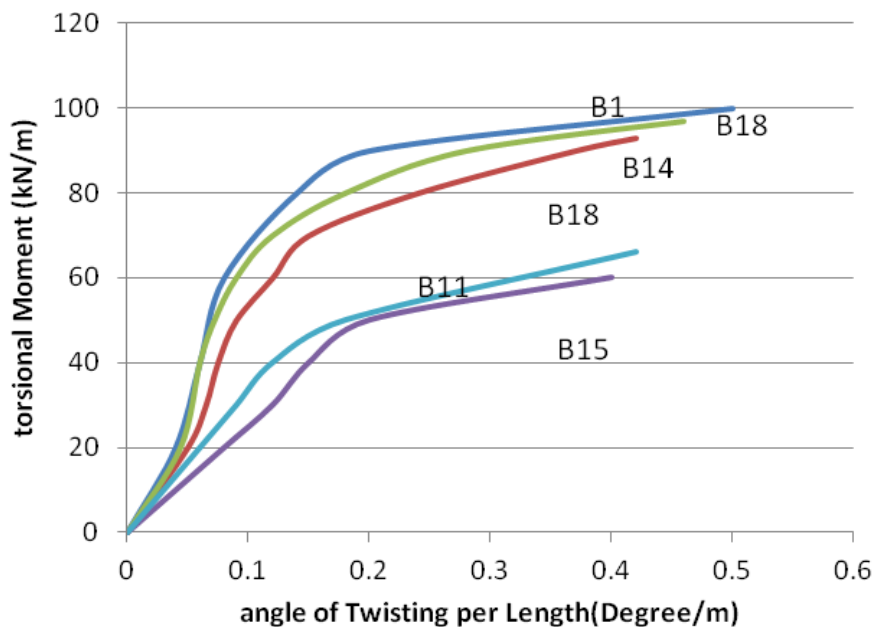

Figure 8. Torsion-angle of twist relation (Second group).

4.3. Crack pattern and crack width for deep beams

For all specimens, after applied load and first crack is formation, loading stop and the crack width is taken by micro crack meter as shown in figure 9 for three selected beams, then the crack width and first

crack load is recorded then the propagation of first crack is highlight by special pen to study cracks propagation, then the load is release and monitoring the specimen for the new crack same procedures that followed in first crack used with new cracks this procedure is follow for all specimens.

The initial crack is very shallow and has narrow width the initial crack formation when stress reach to level at compression path has small area so that the intensity of compressive stress more than strength so that the crack start propagate and when load increments increase the tensile stress corresponding to compressive stress at perpendicular direction increase and the crack width become wider and the main factor that contribute with torsion strength is aggregate interlock.

Finally, the samples of test pictures are given in figure 10.

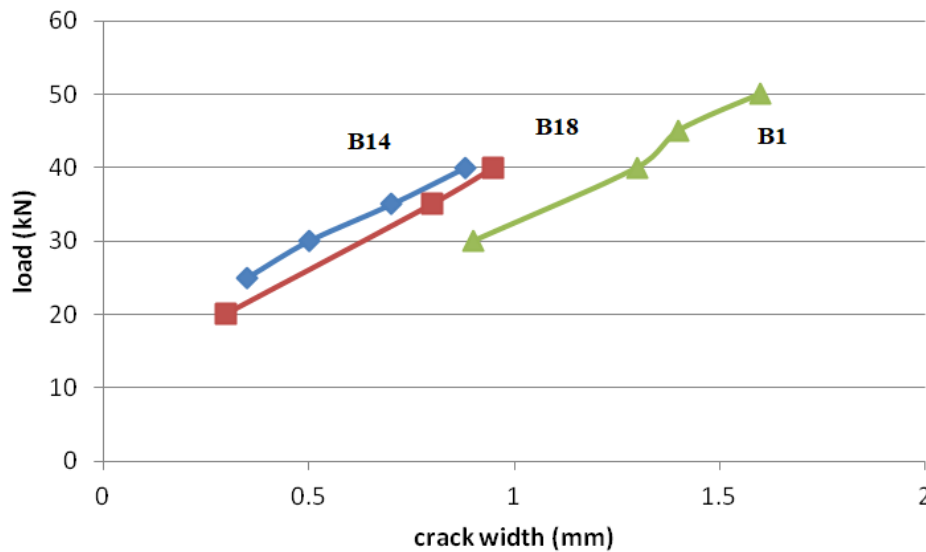

Figure 9. Typical crack width.



Figure 10. Samples of test pictures.

5. Conclusions

According to the obtained results of this study, the following conclusions are given as follows:

- 1- Results of deep beam with maximum size circle opening show that the decreasing ratio of strength in case of without steel fiber.

2-The square opening is weakest because the sharp corners increases the concentration of stresses, and the twisting of solid beam is lower than other and the beams with square opening are higher twisting response comparison with other specimens.

3- The opening size is play main role in strength of deep without steel fiber, when the circle opening is maximum size (15 cm dia.) the strength is drop into (54 %) because the size of opening that cut off shear zone.

4- The steel fibre lowering the reduction in torsion strength by 32% and 30% for tested specimens of rectangle and circle hole shapes respectively.

5- Specimens with circle opening size affectivity is the opening, that located at shear centre at the same time it interrupt compression path, has smaller size that permit more compression stress to follow through the remaining shear zone.

6- The initial crack is very shallow and has narrow width the initial crack formation when stress reach to level at compression path has small area.

6. References

- [1] ACI Committee SP-18 1968 Torsion of Structural Concrete, (ACI- Detroit).
- [2] Alnuaimi A, Al-Jabri K and Hago A 2008 Comparison between solid and hollow reinforced concrete beams, *J. Materials and Structures*, 41 (2) 286–269, <https://doi.org/10.1617/s11527-007-9237-x>.
- [3] Bernardo L and Lopes S 2009 Torsion in High-Strength Concrete Hollow Beams: Strength and Ductility Analysis, *ACI Struc. J* 106 (1) 48-39.
- [4] Abdul-Hussein W 2010 Behavior of Reinforced Reactive Powder Concrete Beams in Torsion, Ph.D. Thesis, University of Technology, Baghdad, Iraq.
- [5] Hadi B 2011 Investigating the Capacity of Ultimate Torsion of Concrete Prismatic Beams with Transverse Spiral Bars, *ijcee-IJNS*. 5 (11) 566-561.
- [6] Waleed A, Hadi N and Enas M 2015 Torsional Behavior of Reinforced Concrete Hollow Core Beams, *JED* 20 (2) 88-72.
- [7] Iraqi Specification, No. 5/1984 2015 Portland Cement, Republic of Iraq.
- [8] Iraqi Specification, No. 45/1984 2015 Aggregate from Natural Sources for Concrete and Construction, Republic of Iraq.
- [6] Richard P and Cheyrezy M H 1994 Reactive Powder Concretes With High Ductility and 200 - 800 Mpa Compressive Strength, *ACI Mater. J.* 144 507-18.
- [9] ASTM C494-16 2016 Standard specification for Chemical Admixtures for Concrete, ASTM International, American Society of Testing Materials, USA.
- [10] ASTM A615/A615M – 16, 2016, Standard Specification for Deformed and Plain Carbon-Steel Bars for Concrete Reinforcement, American Society of Testing Materials, USA.
- [11] ACI 318-19, 2019, Building Code Requirements for Structural Concrete, ACI Committee 318, USA.