

PAPER • OPEN ACCESS

## Experimental Investigations of Enhanced Micro Structured Heat Sinks

To cite this article: Ammar M. Hadi *et al* 2020 *J. Phys.: Conf. Ser.* **1530** 012008

View the [article online](#) for updates and enhancements.



**IOP | ebooks™**

Bringing together innovative digital publishing with leading authors from the global scientific community.

Start exploring the collection—download the first chapter of every title for free.

# Experimental Investigations of Enhanced Micro Structured Heat Sinks

**Ammar M. Hadi<sup>1,2</sup>, Muneer A. Ismael<sup>1</sup>, Maher A.R. Sadiq<sup>2</sup>, Haider A. Alhattab<sup>2</sup>**

<sup>1</sup>Mechanical Engineering Department, Engineering College, University of Basrah, Basrah, Iraq

<sup>2</sup>Electronic and Communication Engineering Department, Engineering College, University of Kufa, Najaf, Iraq

[ammarm.hadi@uokufa.edu.iq](mailto:ammarm.hadi@uokufa.edu.iq)

**Abstract.** In this research, we focus on the performance of heat sink, new configurations of the micro heat sink with comprises of pinned copper pieces of appropriate dimensions have been proposed. Dozens of different shapes micro heat sinks have been manufactured from brass using Laser technique. These heat sinks have been coupled individually with a simulated electronic circuit including a power transistor to freely dissipate the generated heat. Bulk temperatures of heat sink and the power transistor have been measured using a thermal camera. The results showed that, in general, the finned heat sink of either configuration augments heat transfer compared with smooth one. It is found that the maximum percentage reductions in temperature of the transistor are demonstrated with two uncommon configurations, namely the leaves-shaped fin (LSF) 9.352% and the drop-shaped fin (DSF) 9.353%. on the other hand, a staggered wavy fin (SWF) shows minimum percentage reduction in transistor temperature, 0.952%. It has been shown that through this research and by using several models of heat sink, the increase in surface area is not only the factor (major) to increase the heat transfer to the surrounding environment. This makes it possible to design fins with a smaller surface area but more heat dispersion.

**Keywords:** Electronic cooling; natural convection; thermal management; heat dissipation; micro pin fins heat sinks.

## 1. Introduction

Regardless of the cause of overheating, it will in general and primary damage or reduce the efficiency of electronic devices. Electronic components such as integrated circuits, transistors, diodes, resistors, capacitors and among others are designed and built to withstand a particular amounts or levels of heat. In addition, there is a relationship between the performance and the lifetime of any electronic component and its particular range of operating temperature [1].

With speedy development in power physical science, thermal management of small-sized electronic elements has become an extremely difficult drawback for designer. The elements are extremely delicate and therefore the essential issue that determines the lifetime is that the operational temperature [2]. The ability of electronic devices to dissipation the induced heat is a significant factor in hardware, that's why many researchers were focused on induced heat management and electronic cooling. [3].



Recently there are many idea to improve the dissipation of heat sinks such as, hold the segment under a critical temperature by presenting an elite heat sink [4]. Saravanan et al. [2] manufactured these heat sink utilizing miniaturized scale machining strategies and are esteemed to be beneficial where parameters like thermal resistance and heat transfer coefficient are interested, or roughening heat sink surfaces by micro-structured roughness made by laser etching manufacturing technique by Ventola et al. [5] and Lakshmanan et al. [6]. Designing and analysis of micro heat sink for power transistor using CFD was investigated by Alhattab et al. [7]. Fabrication of copper prototypes of heat sink with micro pin fin to explore the flow and thermal performance proposed by Chiu et al. [8]. Microfabrication of short pin fins on heat sink surfaces to augment heat transfer performance was searched by Wang et al. [9]. Improvement of structures of micro-channel heat sinks for chip cooling techniques have been modeled by Gong et al.[10]. Numerical Study and Optimizing on Micro square pin-fin heat sink and staggered arrangement for Electronic cooling was published Zhao et al. [11] and Argun and Kumar [12]. Finally, and not least, enhanced heat transfer from micro pin fins subjected to an impinging jet by Glynn et al. [13], Pavlova et al. [14], and Ndao et al. [15]

However, many parameters influencing the heat sink performance such as the surface area, configuration of the finned surface and heat index are still good vehicle of research [16].

For this purpose, we motivate to fabricate and test several micro heat-sinks with different configurations. Copper pieces are to be prepared in suitable dimensions of power heat sink and roughened using laser technique to several shapes. The test of roughened heat sink is to be achieved by adhesion it to a power transistor which is connected in an electrical circuit. Various power magnitudes are selected to induce various amounts of heat. It is expected that the heat sink with micro heat sink (roughened) will show an improvement in heat dissipation because of increasing in surface area or (h) index or both together. Also the relation between these two factors will be investigated. So by this research we have been able to determine the factors affecting the heat transfer from the heat sink, as it turns out that the surface area is not always the main factor in controlling the amount of heat transferred, but there are other factors which will enable the designer to design the heat sink with a smaller surface area but a larger amount of heat transfer. Thus, greater use of spaces when designing an electrical or electronic circuit will be available

## **2. Methodology.**

### *2.1 Design and manufacturing of Micro heat sink*

A heat sink is a passive heat exchanger that transfers the heat generated by an electronic or a mechanical device to a fluid medium, often air or a liquid coolant, where it is dissipated away from the device. Thereby it allows regulation of the device's temperature at optimal level. The natural convection method is the result of the buoyancy forces that are produced by hot air which result from the heat source. The heated surface of an electronic device would dissipate heat to the surrounding air which gets absorbed and, in turn, becomes hotter. Since hotter air has lower density, it starts to rise upwards and be replaced by colder air.

To investigate and compare uncommon heat sinks, we designed new shapes each of dimensions (1.5 × 1 cm and 0.2 cm height) using AutoCAD (Version 13) as shown in Fig. 1. These shapes are suggested to handle flows of known and unknown directions. Attention has been exerted to keep the area ratio ( $A/A_0$ ) of the finned to smooth heat sink as constant as possible, but this was impossible in some samples. The manufactured copper heat sinks (thermal conductivity of 400 W/m K) are shown in Figure 2. High-precision Fiber 100 watts laser device has been used to cut the copper to get the shapes designed in Fig. 1.

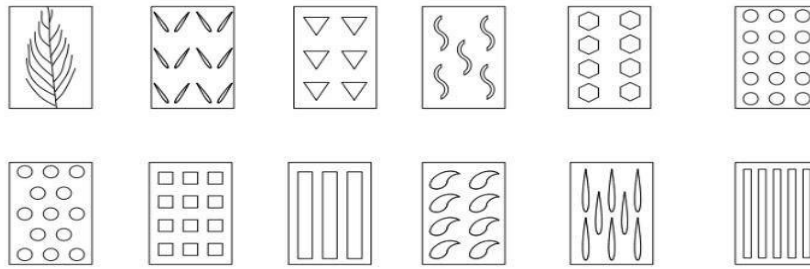

Fig. 1 The designed heat sinks



Fig. 2 Manufactured Micro heat sink.

2.2 Testing circuit and Method

In order to investigate the performance of manufactured heat sinks, the circuit shown in Fig. 3 has been built. The circuit contents are: transistor (LM7805CT); load (resistor); capacitors (2); power supply and the needed breadboard and wires

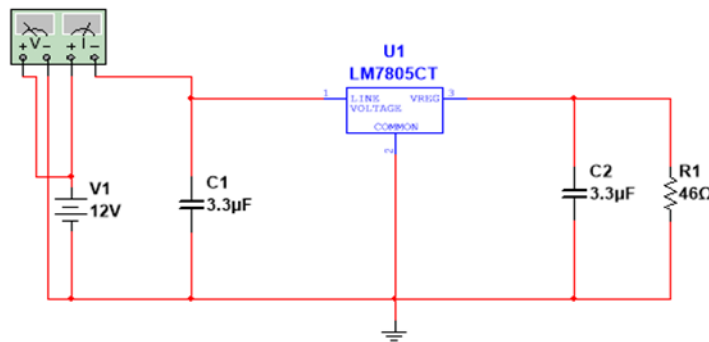
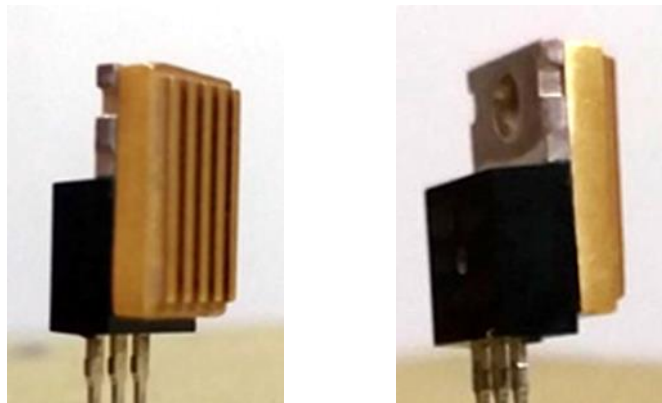

Fig. 3 Heat generation electronic circuit



*Fig. 4 Heat sink instilled on backside of transistor*

Each heat sink has been instilled on backside of transistor as shown in Fig.4. Heat sinks with fins and without fins (flat) were measured at the same time under applying same power to verify the same surrounding conditions. The temperature of the hot surfaces of the heat sink and the transistor itself were measured bulky using a thermal camera FLIR E50 (resolution  $320 \times 240$  pixel with temperature Measurement Range  $-20 \rightarrow +650^\circ\text{C}$ ) shown in Fig.5



*Fig. 5 Thermal Camera (FLIR).*

### 3. Results and discussion.

The experimental transient temperatures of the heat sink are taken with and without finned, they termed as “hs” and “sm”, respectively. As mentioned above, a piece of smooth copper is prepared for comparing the finned heat sink. To inspect the elapsed time to reach the steady-state, the temperature was captured in three different times; 0, 2, and 10 minutes. During the experiments, the temperature is reached to the steady state prior to 10 minutes, thus it is considered as a steady state time. This, relatively, little steady state time is due to the small mass of the heat sink and the transistor. Table 1 depicts the transient results of the different heat sinks. Quantitatively, the results show that the finned sink is hotter than smooth one. This is a promising indication to the feasibility of the suggested configurations of the finned heat sinks, where the heat is extracted from the transistor and released to surrounding medium. Now, we commence with recording the temperature of the transistor with and without heat sink. Since the experiments on 12 specimens of heat sink requires some time to replace the heat sink and waiting until the steady state time, the environments surrounding each specimen were accidentally altered. Therefore, the measurement of temperatures correspond to each smooth heat sink has been undertaken in slightly different conditions. This reason causes slight discrepancies in temperatures of both the heat sink and the transistor as shown in Table 1 and 2. Another reason arises these discrepancies is that the present problem is under the effect of natural convection. As such, the role of environments is more pronounced than the forced convection problem. Table 2 presents the temperatures of transistor with and without heat sinks at steady state time. To provide a reasonable criterion of the action of the heat

sink and attenuate the effect of different environmental conditions, we calculated the percentage difference between the transistor temperatures corresponding to the smooth and finned heat sinks. The percentage reductions shown in Table 2 are taken with respect to the transistor temperature corresponding to the smooth heat sink. However, focusing on the percentage reduction in transistor temperature can be achieved with the help of the bar graphs shown in Fig. 6. This graph shows that the maximum reduction in transistor temperature (about 9.2%) is obtained with leaves-shaped fin (LSF) and the inline drop pinned (IDP). Compared with the remainder shapes, the inline cylindrical pin heat sink manifests large reduction ratio (about 8%). On the other hand, the staggered wavy fin (SWF) experiences the lowest temperature reduction (about 0.95%). To give plausible explanations for these results, it is worth to mention that not always the surface area of the extended fins augments the heat dissipation, but the configuration and the paths between fins are also play a significant role in natural convection. For example, when the paths between fins are narrow and tortuous, the rises convective currents may be trapped between these paths, thus experiencing a resistance to the heat transfer. Moreover, the direction of the air rising by convection and conveying the heat from the heat sink is also affects the process of heat dissipation, where when the direction of the flow is unknown, the pin fin is recommended. Hence it can be evolved from the aforementioned results that the area ratio ( $A/A_o$ ) ranging between 1.28 and 1.3 is a perfect range as it compromises between the necessary extended area and the flow resistance resulting from the paths between fins. The lowest reduction ratio of the SWF can be attributed now to the small area ratio ( $A/A_o = 1.182$ ). The highest area ratio of of IRP and SCP shapes give no more temperature reduction than those of LSF and IDP because dense fin pattern generates too much restriction to airflow, and then exerting a resistance against the warm air from rising out of the heat sink efficiently.





Another issue can be drawn from Table 2 and Fig. 6, that is the non-rounded pin fins, like hexagonal, rectangular, and triangular pin fins, show, relatively, lower temperature reduction despite the available paths they provide. This result can be explained by the separation of the convective rising air due to the nature of the pin.

The coefficient of convective heat transfer of each heat sink can be computed from cooling Newton relation;

- $h=Q/(A(T_2-T_1))$  (1)

where  $A$  is the surface area where the heat transfer takes place,  $T_1$  is the temperature of the surrounding fluid,  $T_2$  is the temperature of the solid surface,  $h$  is the heat transfer coefficient and  $Q$  is the heat flux generated in the transistor. The results of the coefficient of convective heat transfer for all types of heat sinks explain in Fig.7

Table 1: Transient temperature of the heat sink

Sample	Description	Shape	$A/A_o$	Temperature in three times (°C)			$h$ ( $w/m^2.k$ )
				0 min.	2 min.	10 min.	
ICP	Inline cylindrical pin		1.28	sm/33.8 hs/33.6	50.8 51.6	69.9 73.0	153.789996
SCP	Staggered Cylindrical pin		1.465	sm/31.7 hs/31.5	505.6 52.5	68.4 70.1	117.77104
IRP	Inline rectangular pin		1.34	sm/31.6 hs/31.3	49.4 54.7	74.9 76.7	128.763121
ITP	Inline Triangular pin		1.201	sm/32.7 hs/32.5	54.5 57.4	69.2 78.7	149.286552



















IHP	Inline hexagonal pin		1.271	sm/33.3 hs/32.9	52.5 53.5	73.4 77.2	141.855964
IDP	Inline Drop-shape pin		1.291	sm/31.5 hs/31.4	50.5 52.5	72.5 73.2	146.624385
LRF	Longitudinal rectangular fin		1.245	sm/33.1 hs/33.1	40.0 47.2	68.5 70.9	141.643754
LBF	Longitudinal block fin		1.258	sm/31.8 hs/31.6	47.5 49.9	70.1 71.6	140.205562
SAF	Staggered Airfoil fin		1.28	sm/32.3 hs/31.9	41.4 48.4	74.4 75.6	142.931393
SWF	Staggered wavy fin		1.182	sm/32.5 hs/32.1	54.5 59.3	72.7 78.6	145.373507
ZAF	Zigzag airfoil fin		1.218	sm/32.5 hs/32.1	52.5 57.3	70.9 80.1	146.515125
LSF	Leaves-shaped fin		1.283	sm/33.5 hs/32.9	53.1 53.9	71.0 74.1	157.346257

Table 2: The steady state temperature of transistor

Sample	Description	Shape, A/Ao	Temperatures with and without heat sink (°C)		% Reduction In Temperature
			sm	hs	
ICP	Inline cylindrical pin	 1.28	83.4	76.7	8.033
SCP	Staggered Cylindrical pin	 1.465	86.7	83.0	4.268
IRP	Inline rectangular pin	 1.34	86.7	83.0	4.267
ITP	Inline Triangular pin	 1.201	82.9	81.1	2.171
IHP	Inline hexagonal pin	 1.271	84.7	80.8	4.604
IDP	Inline Drop-shape pin	 1.291	86.6	78.5	9.353
LRF	Longitudinal rectangular fin	 1.243	85.7	81.9	4.434
LBF	Longitudinal block fin	 1.258	86.6	81.9	5.427
SAF	Staggered Airfoil fin	 1.28	86.1	80.1	6.969

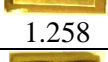
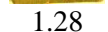

SWF	Staggered wavy fin	 1.182	84.0	83.2	0.952
ZAF	Zigzag airfoil fin	 1.218	83.4	81.3	2.518
LSF	Leaves-shaped fin	 1.283	83.4	75.6	9.352

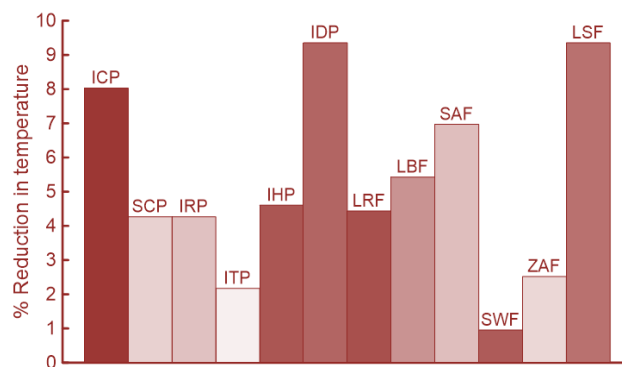

Fig. 6 Reduction ratio of the transistor temperature of different heat sinks.

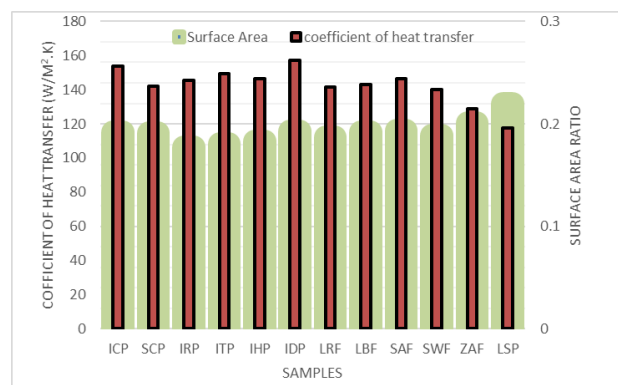

Fig.7 Coefficient of convective heat transfer (h) of different samples heat sinks

**4. Conclusions.**

Heat sinks of high thermal conductivity are designed to maximize surface area in contact with the cooling medium (air) and to cool the surface of a power transistor. Experiments were conducted by simulating an electronic circuit involving a power transistor. The manufactured heat sinks were instilled individually on the back of the transistor and the temperatures were captured using a thermal camera. The results have led to the following concluding remarks.

1. Quantitatively, the pin and longitudinal fins provide extra surface area to the heat sinks and hence contribute in reducing the temperature of hot bodies.



2. The surface area of the heat sink is not the solely parameter that responsible of releasing heat, but the configuration and distribution of the extended surface also contribute in evaluating the performance of the heat sink.
3. An area ratio ranging between 1.282 and 1.291 show the best temperature reduction.
4. Novel shapes of heat sinks have demonstrated promising improvements in reduction the temperature of hot transistor; these are the leaves-shape fins (LSF) and the inline drop-shaped pin fin (IDP), where the temperature reduction ratio is about 9.3%.
5. The staggered wavy fin configuration (SWF) experiences the lowest reduction of temperature, about 0.95%.

The non-rounded pin fins and the zigzag fins demonstrated lower temperature reduction despite their surface area are not so low.

The present work is to be extended by manufacturing the same configurations of heat sinks described above but from Aluminum. This future work is preferable from the economic point of view, where the Aluminum is lower cost than Copper and it has different thermal capacity and hence it is interested to get in such a study.

#### **Conflict of interest.**

There is no conflict between the four authors of this work

#### **References.**

- [1] A. A. Almubarak, "The Effects of Heat on Electronic Components," *Int. J. Eng. Res. Appl.*, vol. 07, no. 5, pp. 52–57, 2017.
- [2] V. Saravanan and C. K. Umesh, "Numerical comparison for thermo-hydraulic performance of pin fin heat sink with micro channel pin fin heat sink," *Sādhanā*, vol. 43, no. 7, pp. 1–15, 2018.
- [3] H. Search, C. Journals, A. Contact, M. Iopscience, and I. P. Address, "Heat Transfer Enhancement by Finned Heat Sinks with Micro-structured Roughness," *MicroTherm '2013 — Microtechnology Therm. Probl. Electron.*, vol. 012009, 2014.
- [4] N. Matsumoto, T. Tomimura, and Y. Koito, "Heat Transfer Characteristics of Square Micro Pin Fins under Natural Convection," *J. Electron. Cool. Therm. Control*, vol. 4, no. September, pp. 59–69, 2014.
- [5] L. Ventola, L. Scaltrito, S. Ferrero, G. Maccioni, E. Chiavazzo, and P. Asinari, "Micro-structured rough surfaces by laser etching for heat transfer enhancement on flush mounted heat sinks," *J. Phys. Conf. Ser.*, vol. 525, no. 1, 2014.
- [6] S. Lakshmanan and A. Saravanan, "CFD analysis for rate of cooling of heat sink for CPU," vol. 3, pp. 23–27.
- [7] H. A. Alhattab, M. A. R. Sadiq Al-Baghdadi, R. S. Hashim, and A. H. Ali, "Design of micro heat sink for power transistor by using CFD," in *Al-Sadiq International Conference on Multidisciplinary in IT and Communication Techniques Science and Applications, AIC-MITCSA 2016*, 2016, pp. 268–272.
- [8] and C. R. Y. H. C. Chiu, R. H. Hsieh, K. Wang, J. H. Jang, "The heat transfer characteristics of liquid cooling heat sink with micro pin fins," *Int. Commun. Heat Mass Transf.*, vol. 86, pp. 174–1890, 2017.
- [9] and M. T. N. C. Wang, Y. Yu, T. Simon, T. Cui, "Microfabrication of short pin fins on heat sink surfaces to augment heat transfer performance," *Intersoc. Conf. Therm. Thermomechanical Phenom. Electron. Syst. IThERM*, no. 612, pp. 944–950, 2012.

- [10] L. Gong, J. Zhao, and S. Huang, “Numerical study on layout of micro-channel heat sink for thermal management of electronic devices,” *Appl. Therm. Eng.*, vol. 88, pp. 480–490, 2015.
- [11] J. Zhao, S. Huang, L. Gong, and Z. Huang, “Numerical study and optimizing on micro square pin-fin heat sink for electronic cooling,” *Appl. Therm. Eng.*, vol. 93, pp. 1347–1359, 2016.
- [12] K. S. Arjun and R. Kumar, “Optimization of micro pin-fin heat sink with staggered arrangement,” *Therm. Sci.*, vol. 22, no. 6, pp. 2919–2931, 2018.
- [13] C. Glynn and D. B. Murray, “Jet Impingement Cooling In Microscale,” *ECI Int. Conf. Heat Transf. Fluid Flow Microscale*, no. September, pp. 1–7, 2005.
- [14] A. Pavlova and M. Amitay, “Electronic cooling using synthetic jet impingement,” *J. Heat Transfer*, vol. 128, no. 9, pp. 897–907, 2006.
- [15] and M. K. J. S. Ndao, H. J. Lee, Y. Peles, “Heat transfer enhancement from micro pin fins subjected to an impinging jet,” *Int. J. Heat Mass Transf.*, vol. 55, no. 1–3, pp. 413–421, 2012.
- [16] R. Sabarish, “Experimental Investigation of Heat Transfer Analysis on Nano Graphene Coated Extended,” 2015.