



COMPARISON BETWEEN LS-PWM AND LPS-PWM FOR SWITCHING-CAPACITOR (SC) INVERTER

Ali K. Abdul-Abbas¹ and Shafaa M. Salih²

¹Department of Electrical Engineering, College of Engineering -Basra University, Iraq.
Email: ali_univbasra75@yahoo.com

²Department of Computer Engineering, College of Engineering -Basra University. Iraq.
Email: shafaa1976_21@yahoo.com

ABSTRACT:

A two modulation methods of the switching-capacitor inverter are proposed. The inverter output voltage is larger than the input voltage by connect switching-capacitor in series and in parallel respectively. The level output voltages are decided by number of the capacitor. Five capacitors are used to obtain eleven level in output voltage waveform. The proposed inverter is driven by the LS-PWM and LPS-PWM methods. The circuit configuration, states operation and simulation results by using MATLAB/SIMULINK are presented in this paper. The simulation results demonstrated best LPS-PWM method compared with LS-PWM in terms THD of output voltage.

KEYWORDS: inverter, voltage, capacitor, waveform.

1. INTRODUCTION

AC-DC converters with rise voltage gain are desired in considerable industrial applications such as front-end parts for neat energy sources, Uninterruptible Power Supplies (UPS), Electrical Vehicles (EVs), and Distributed Generation (DG) systems (Yoo et al., 2008; Lu et al., 2017). EVs are distinguished by motor drive equipments, where power electronic is used in electric power conversion such as Pulse Width Modulation (PWM) inverters and DC/DC converters (Emadi et al., 2006).

The inverter with a step-up transformer, the Z-source inverter, and single stage flyback inverter are used to obtain high input voltage/ output voltage ratio (Hu et al., 2017; Voglitsis et al., 2017). But the transformer or the inductor creates the inverter which is big because they have large size magnetic cores to bear the high power (Chandrasekaran and Gokdere, 2004).

The multilevel inverter techniques are used a lot of attention because the attractive solution for high power applications. The output voltage of The multilevel inverter is graduate waveform, lower common-mode voltages, reduced (dv/dt) voltage and lower Total Harmonic Distortion (THD) (Franquelo et al., 2008). The multilevel inverter has numerous topologies; such as, the cascade H-bridge (CHB) inverter (Karasani et al., 2017), the Neutral Point Clamped PWM (NPC-PWM) inverter (Rodriguez et al., 2009) and the flying capacitor inverter (Kou et al., 2004). These topologies have a major number of switching device or numerous input voltage sources.

A Switched Capacitor (SC) inverter outputs have higher outputs and large gain ratio in a similar way to the charge pumps (Ardashir et a., 2017). A SC inverter using series and parallel conversion is based on the boost converter and a full-wave bridge inverter (Hinago, and Koizumi, 2010).

The SC inverter has the lower number of devices contrast to the conventional multilevel inverters (Fong et al., 2017). There are numerous modulation methods to drive a SC inverter: the multicarrier PWM (McGrath and Holmes, 2002) , the space vector modulation (Das and Narayanan, 2012), the hybrid modulation and the selective harmonic elimination (Agelidis et al., 2008). The Level and Phase Shifted PWM (LPS-PWM) method is incorporation of the Level Shifted PWM (LS-PWM) and Phase Shifted PWM (PS-PWM) (Hinago and Koizumi 2011).

In this paper, four stages of SC inverter driven by LS-PWM and PS-PWM methods are proposed. The voltage ripple and the losses in this inverter are less comparable with

conventional inverters. The operation stage principle and simulation results are shown and compared based on a newly four stage SC inverter.

2. MODEL DESCRIPTION AND STATE OF OPERATION IN LS-PWM METHOD

A model configuration of the four layer switching-capacitor (SC) inverter is shown in Fig. 1 (Hinago, and Koizumi, 2010). The one phase circuit, switches S_{ai} , S_{bi} , and S_{ci} ($i=1,2,3,4$) are used which switch for the capacitors C_h ($h=1,2,3,4,5$) that connected in parallel to charge and in series to discharge so that the output of the inverter a higher voltage than the input voltage E_{in} .

The switches S_{ai} are utilized for series attachment of capacitors and switches S_{bi} and S_{ci} are utilized for parallel attachments of capacitors. The condenser C_3 couple in parallel to the supply E_{in} can be rejected when using ideal voltage source performs. The full-bridge inverter used switches S_1 - S_4 in the output stage and low pass filter is constructed from an inductor L and capacitor C with resistive or inductive loads can be connected in the output terminal of the inverter.

In LS-PWM technique, five stages operation in each half cycle of reference voltage can be described in the following(referred to Fig. 2).

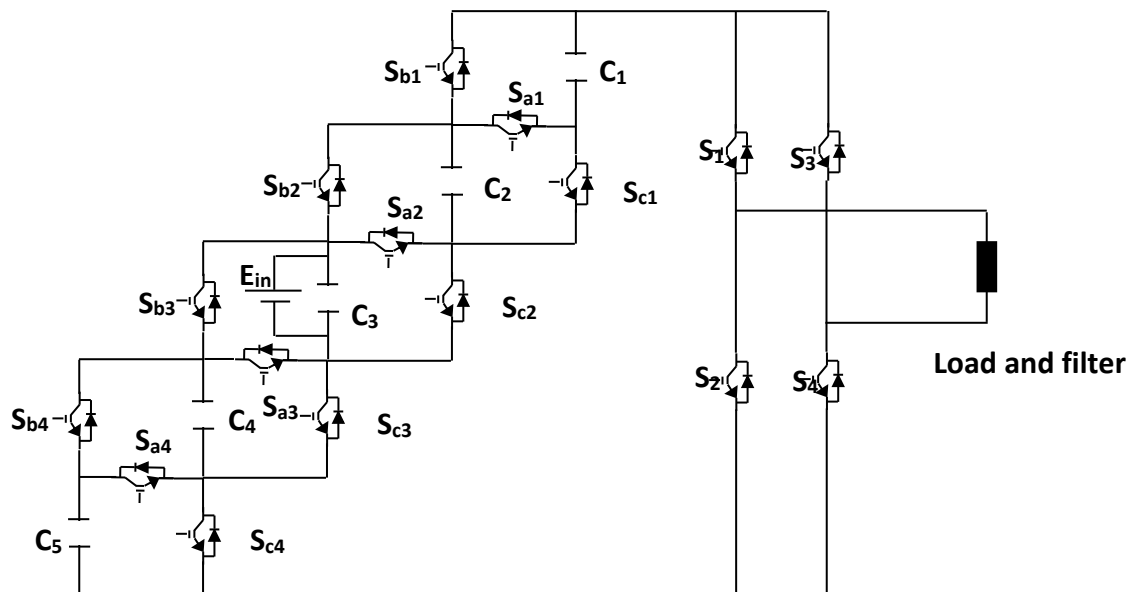

Fig. 1. Proposed diagram of switching capacitor circuit.

Stage 1

When the time period (t) is satisfied ($0 \leq t \leq t_1$) in Fig. 2, the switches S_{ai} are turned off by the pulses in gate-source voltage V_{GSai} but the switches S_{bi} and S_{ci} are turned on by the drive in gate-source voltages V_{GSbi} and V_{GSci} respectively.

The switches S_{bi} and S_{ci} are derived by the same pulses. The switches S_1 and S_2 are turned on or off alternately while the switches S_3 is maintained off states and S_4 is preserved on states. Therefore, the states shown in Fig. 3(a) and (b) are transform alternately and the output voltage V_{out} occupy between 0 and E_{in} .

Stage 2

When the condition for time duration is satisfied ($t_1 \leq t \leq t_2$) in Fig. 2. The upper switches S_{a1} , S_{b1} , and S_{c1} are switched alternative by the gate-source voltage V_{GSa1} , V_{GSb1} , and V_{GSc1} , respectively. While the state lower switches S_{ai} ($i=2,3,4$) is turned off and S_{bi} and S_{ci} ($i=2,3,4$) are maintained turn on.

The condenser C_1 is charged by the negative current i_{C1} as shown in Fig. 3(b) and discharged by positive current i_{C1} as shown in Fig. 3 (c). So the output voltage satisfied the following relation

$$V_{out} = E_{in} + V_{C1} \quad 1$$

Where V_{C1} is the voltage across the capacitor C_1 . Therefore, the output voltage V_{out} is charging between E_{in} and $E_{in} + V_{C1}$.

Stage 3

When the period (t) satisfied ($t_2 \leq t \leq t_3$) in Fig. 2. The switches S_{a2} , S_{b2} , and S_{c2} are switched on while S_{a1} , S_{b1} , and S_{c1} are kept on state however S_{ai} ($i=3,4$) is kept turn on while S_{bi} and S_{ci} ($i=3,4$) are kept turn off. The condenser C_2 is charged by the negative current i_{C2} as shown in Fig. 3(d) and discharged by the positive current i_{C2} .

The output voltage V_{out} is

$$V_{out} = E_{in} + V_{C1} + V_{C2} \quad 2$$

Where V_{C2} is the potential difference on the capacitor C_2 . Thus, the output voltage is charging between $E_{in} + V_{C1}$ and $E_{in} + V_{C1} + V_{C2}$ alternately.

Stage 4

In the interval ($t_3 \leq t \leq t_4$), the full-bridge inverter switches S_1 and S_4 is turn on while S_2 and S_3 are turn off.

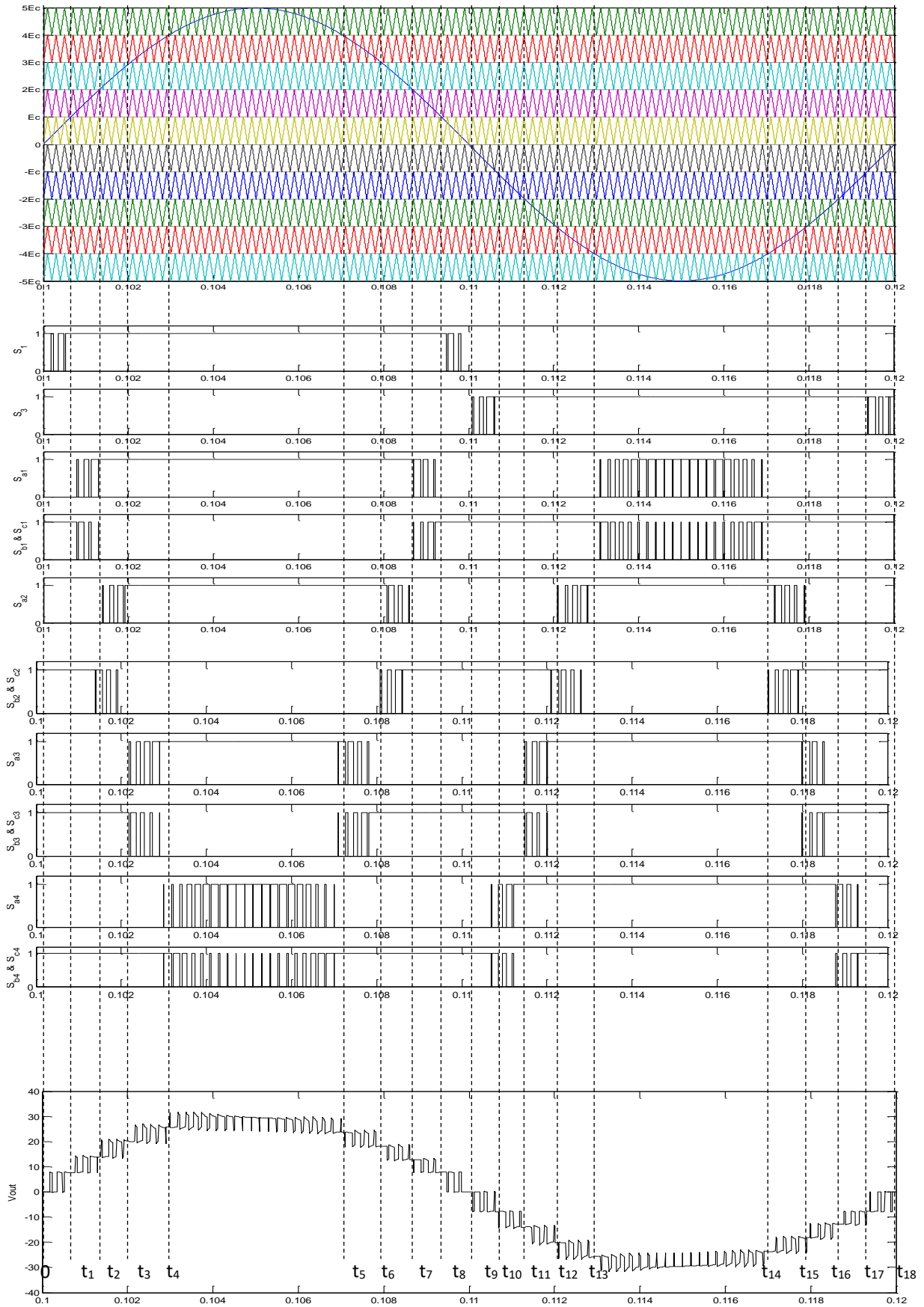

Fig. 2. Diagram of waveform in LS-PWM technique.

The switches S_{ai} ($i=1,2$) are turned on while S_{bi} and S_{ci} ($i=1,2$) are turn off. However, switches S_{a3} , S_{b3} and S_{c3} are turned on or off alternately and the switches S_{a4} is turning off while S_{b4} and S_{c4} are turning on. So the capacitor C_1 and C_2 are discharging and capacitor C_4 is charging and discharging alternately while capacitor C_5 is charging as shown in Fig. 3 (e). In these states, the output voltage V_{out} change between $E_{in} + V_{C1} + V_{C2}$ and $E_{in} + V_{C1} + V_{C2} + V_{C4}$ respectively.

Stage 5

This stage can be described during the interval which is ($t_4 \leq t \leq t_5$), the full-wave inverter switches keep of the states and switches S_{ai} ($i=1,2,3$) are turned on while switches S_{bi} and S_{ci} ($i=1,2,3$) are turned off. The switches S_{a4} , S_{b4} and S_{c4} are turned on or off alternately as shown in Fig. 3 (f).

In this case, the output voltage V_{out} change between $E_{in} + V_{C1} + V_{C2} + V_{C4}$. and $E_{in} + V_{C1} + V_{C2} + V_{C4} + V_{C5}$ respectively.

After time (t_5), the five states are iterative by a half cycle of reference voltage and illustrated in Table 1. For the positive half cycle of the reference wave and Table.2 in the negative half cycle of the reference wave by purpose $V_{C1} = V_{C2} = V_{C4} = V_{C5} = E_{in}$.

Table 1. Positive half cycle of reference wave for $V_{C1} = V_{C2} = V_{C4} = V_{C5} = E_{in}$

State	Period of state	$S_{a1} = \overline{S_{b1}} = \overline{S_{c1}}$	$S_{a2} = \overline{S_{b2}} = \overline{S_{c2}}$	$S_{a3} = \overline{S_{b3}} = \overline{S_{c3}}$	$S_{a4} = \overline{S_{b4}} = \overline{S_{c4}}$	$S_1 = \overline{S_2}$	$S_3 = \overline{S_4}$	V_{out}
1	$0 \leq t \leq t_1$	0	0	0	0	$0 \leftrightarrow 1$	0	$0 \leftrightarrow E_{in}$
2	$t_1 \leq t \leq t_2$	$0 \leftrightarrow 1$	0	0	0	1	0	$E_{in} \leftrightarrow 2E_{in}$
3	$t_2 \leq t \leq t_3$	1	$0 \leftrightarrow 1$	0	0	1	0	$2E_{in} \leftrightarrow 3E_{in}$
4	$t_3 \leq t \leq t_4$	1	1	$0 \leftrightarrow 1$	0	1	0	$3E_{in} \leftrightarrow 4E_{in}$
5	$t_4 \leq t \leq t_5$	1	1	1	$0 \leftrightarrow 1$	$0 \leftrightarrow 1$	0	$4E_{in} \leftrightarrow 5E_{in}$
6	$t_5 \leq t \leq t_6$	1	1	$0 \leftrightarrow 1$	0	1	0	$3E_{in} \leftrightarrow 4E_{in}$
7	$t_6 \leq t \leq t_7$	1	$0 \leftrightarrow 1$	0	0	1	0	$2E_{in} \leftrightarrow 3E_{in}$
8	$t_7 \leq t \leq t_8$	$0 \leftrightarrow 1$	0	0	0	1	0	$E_{in} \leftrightarrow 2E_{in}$
9	$t_8 \leq t \leq t_9$	0	0	0	0	$0 \leftrightarrow 1$	0	$0 \leftrightarrow E_{in}$

Table 2. Negative half cycle of reference wave for $V_{C1}=V_{C2}=V_{C4}=V_{C5}=E_{in}$

State	Period of state	$S_{a1}=\overline{S_{b1}}=\overline{S_{c1}}$	$S_{a2}=\overline{S_{b2}}=\overline{S_{c2}}$	$S_{a3}=\overline{S_{b3}}=\overline{S_{c3}}$	$S_{a4}=\overline{S_{b4}}=\overline{S_{c4}}$	$S_1=\overline{S_2}$	$S_3=\overline{S_4}$	V_{out}
10	$t_9 \leq t \leq t_{10}$	0	0	0	0	0	$0 \leftrightarrow 1$	$0 \leftrightarrow -E_{in}$
11	$t_{10} \leq t \leq t_{11}$	0	0	0	$0 \leftrightarrow 1$	0	1	$-E_{in} \leftrightarrow -2E_{in}$
12	$t_{11} \leq t \leq t_{12}$	0	0	$0 \leftrightarrow 1$	1	0	1	$-E_{in} \leftrightarrow -3E_{in}$
13	$t_{12} \leq t \leq t_{13}$	0	$0 \leftrightarrow 1$	1	1	0	1	$-E_{in} \leftrightarrow -4E_{in}$
14	$t_{13} \leq t \leq t_{14}$	$0 \leftrightarrow 1$	1	1	1	0	$0 \leftrightarrow 1$	$-E_{in} \leftrightarrow -5E_{in}$
15	$t_{14} \leq t \leq t_{15}$	0	$0 \leftrightarrow 1$	1	1	0	1	$-E_{in} \leftrightarrow -4E_{in}$
16	$t_{15} \leq t \leq t_{16}$	0	0	$0 \leftrightarrow 1$	1	0	1	$-E_{in} \leftrightarrow -3E_{in}$
17	$t_{16} \leq t \leq t_{17}$	0	0	0	$0 \leftrightarrow 1$	0	1	$-E_{in} \leftrightarrow -2E_{in}$
18	$t_{17} \leq t \leq t_{18}$	0	0	0	0	0	$0 \leftrightarrow 1$	$0 \leftrightarrow -E_{in}$

3. OPERATION PRINCIPLE OF SC INVERTER IN LPS-PWM METHOD

Fig. 4 illustrates the basic pulse in the LPS-PWM method, the reference waveforms e_{ref} is splitted into five levels. With triangle waveform t_{ri1} is employed between $3B_c$ and $5B_c$, another triangle waveform t_{ri3} is employed between B_c and $3B_c$, and triangle t_{ri5} is employed between $-B_c$ and B_c , and t_{ri7} is employed between $-3B_c$ and $-B_c$, and t_{ri9} is employed between $-5B_c$ and $-3B_c$ respectively. Which are coincide in the same phase at the carrier frequency f_{ref} and their magnitude of B_c . The other triangle waveforms t_{ri2} , t_{ri4} , t_{ri6} , t_{ri8} , and t_{ri10} are put on each level but their phases are shifted by 180 degree with respect to the previous group so it is called to this modulation as level and phase shifted (LPS).

The operation principle can be described by the following:

- 1- when $e_{ref} > t_{ri6}$ so **S_1 is on and S_2 is off** but when $e_{ref} > t_{ri5}$ so **S_3 is on and S_4 is off.**
- 2- when $e_{ref} > t_{ri1}$ and $e_{ref} < t_{ri9}$ so **S_{a1} is on and S_{b1}, S_{c1} are off.**
- 3- when $e_{ref} > t_{ri2}$ and $e_{ref} < t_{ri10}$ so **S_{a2} is on and S_{b2}, S_{c2} are off.**
- 4- when $e_{ref} > t_{ri3}$ and $e_{ref} < t_{ri7}$ so **S_{a3} is on and S_{b4}, S_{c4} are off.**
- 5- when $e_{ref} > t_{ri4}$ and $e_{ref} < t_{ri8}$ so **S_{a4} is on and S_{b3}, S_{c3} are off.**

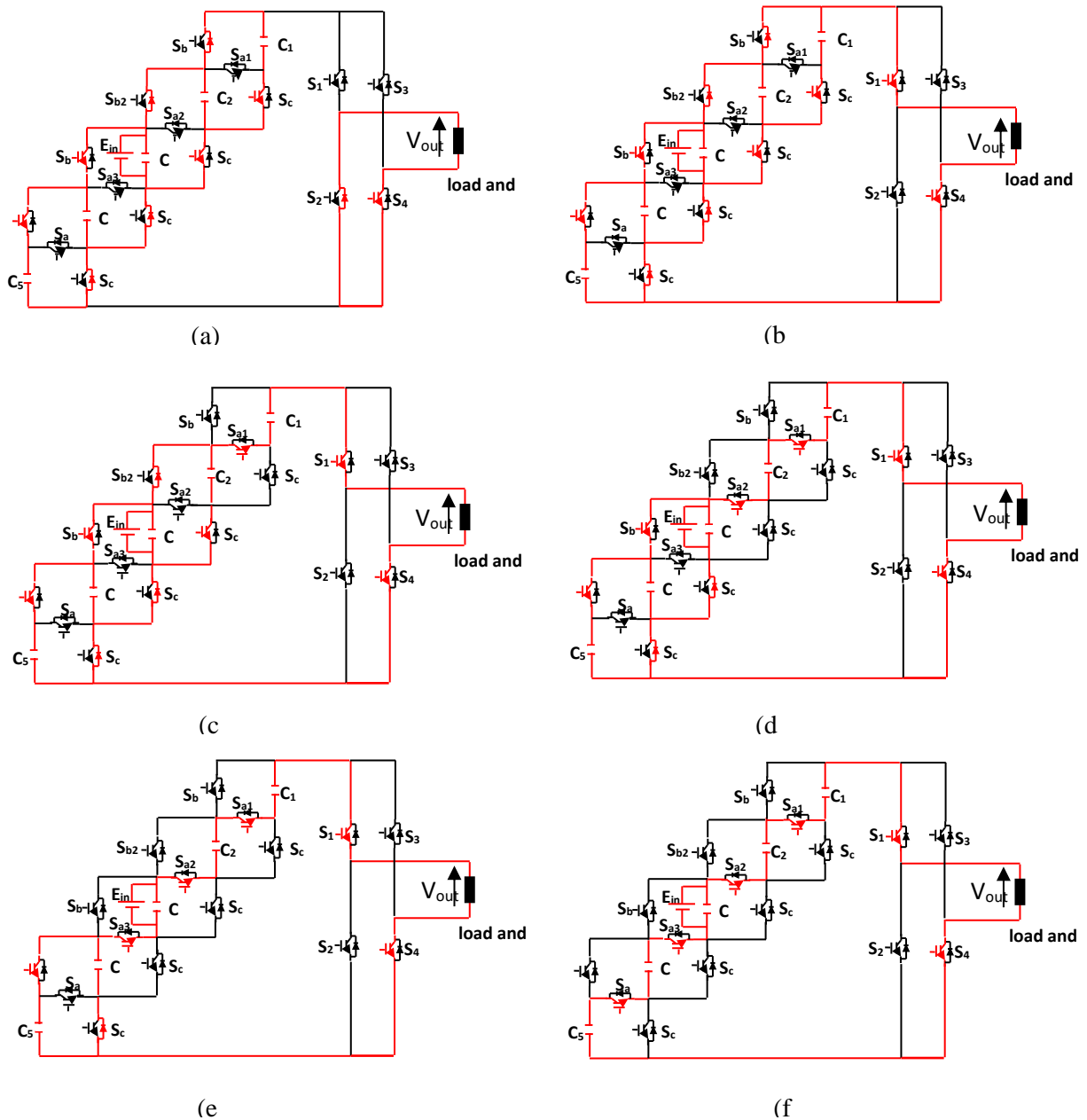

Fig. 3. Proposed diagram of operation in different stage (a) $V_{out}=0$, (b) $V_{out}=E_{in}$, (c) $V_{out}=E_{in}+VC_1$, (d) $V_{out}=E_{in}+VC_1+VC_2$, (e) $V_{out}=E_{in}+VC_1+VC_2+VC_4$, (f) $V_{out}=E_{in}+VC_1+VC_2+VC_4+VC_5$.

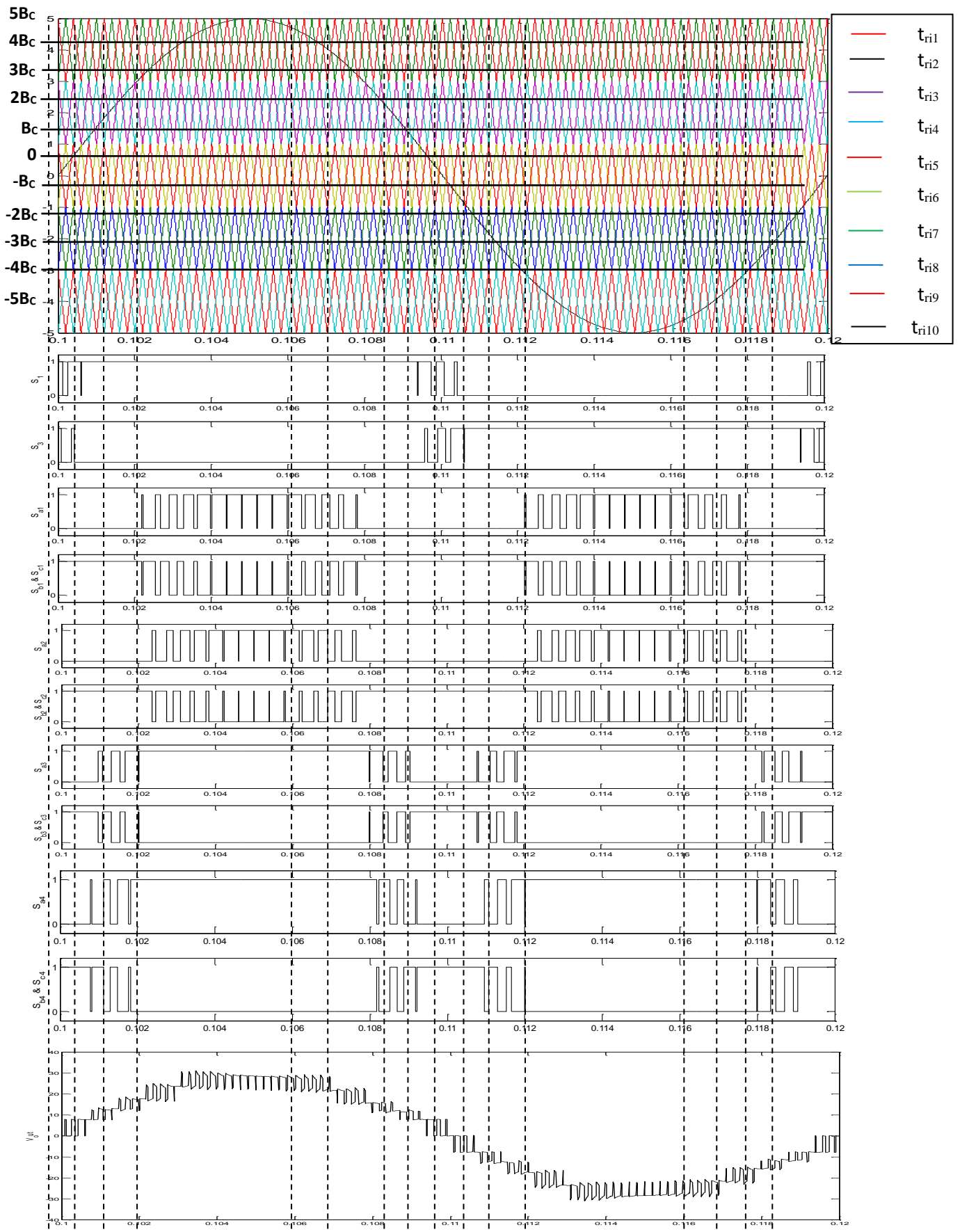

Fig. 4. Diagram of waveform in LPS-PWM technique.

4. SIMULATION BLOCKS OF LS-PWM AND LPS-PWM TECHNIQUES

This part is devoted to the simulation block of the switched-capacitor inverter. Simulation diagram is divided into three blocks (as shown in Fig. 5): carrier and reference block, derive circuit and power circuit.

The power circuit is common for both techniques (as shown in Fig. 6), while each drive circuit is specified for certain techniques. The first drive circuit generation pulse for the power circuit using LS-PWM(as shown in Fig. 7), whereas the pulse generation of the second drive circuit is based on LPS-PWM(as shown in Fig. 8). In addition, each technique has its own reference and carrier block.

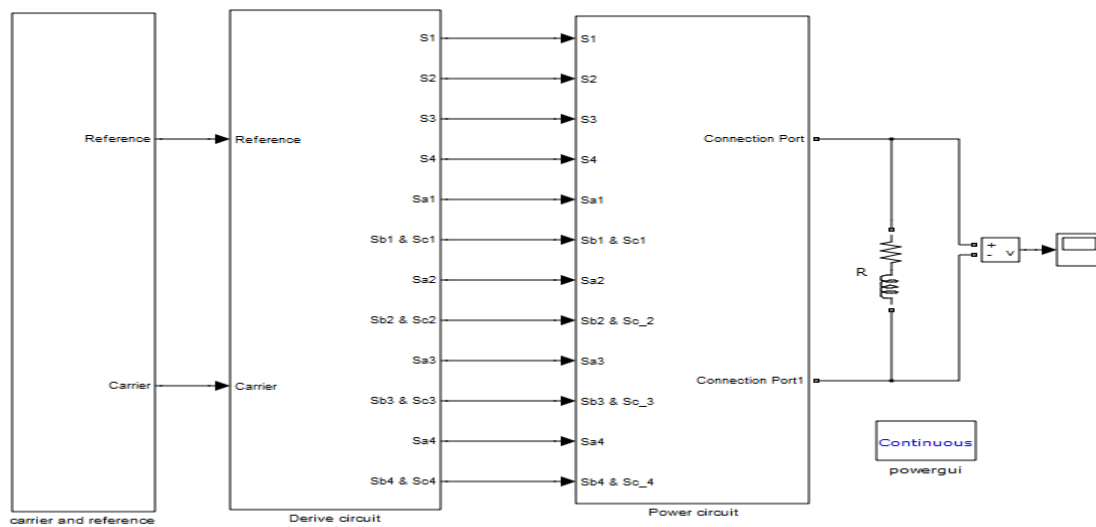

Fig. 5. Block diagram of SC inverter.

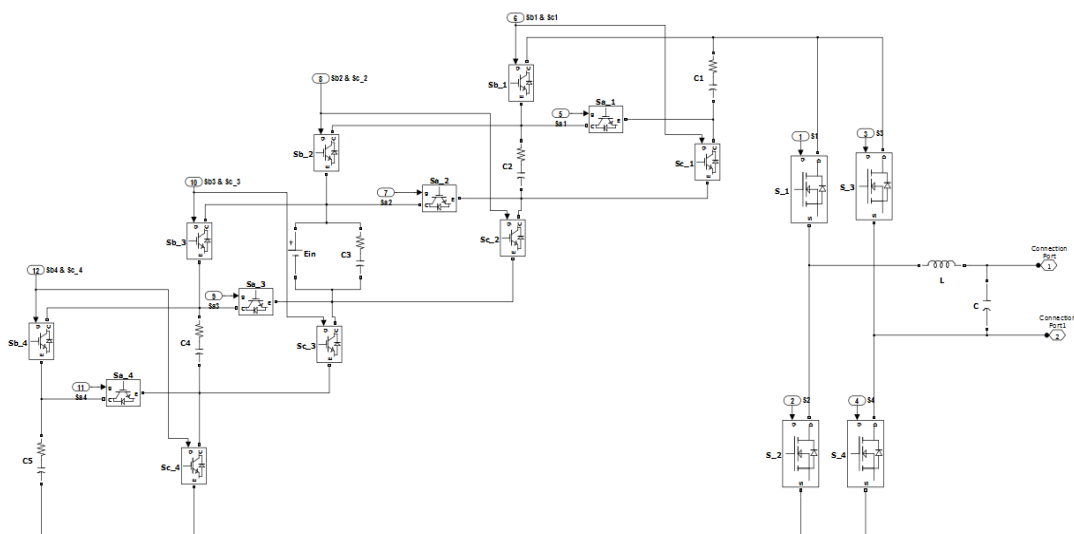

Fig. 6. Block diagram of power circuit.

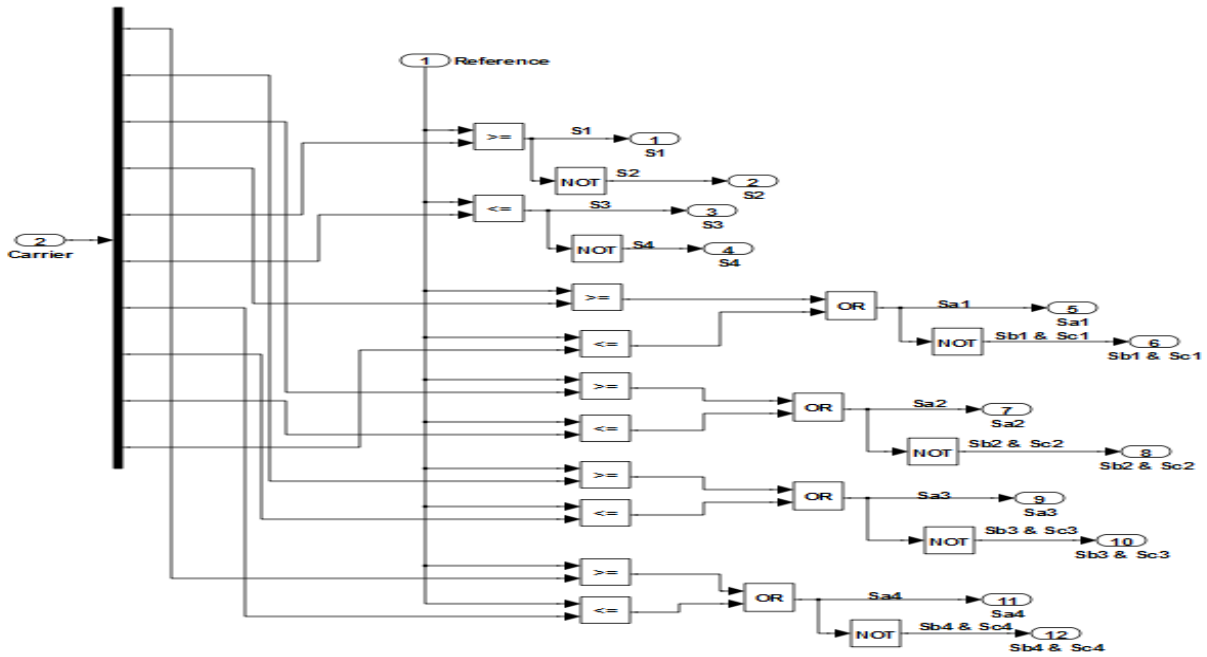

Fig. 7. Block diagram of drive circuit for LS-PWM technique.

5. SIMULATION RESULT

The switched-capacitor inverter is modeled in SIMULINK/MATLAB using power system set. The load voltage after filter, output voltage from inverter and voltage in capacitor C1 for LS-PWM and LPS-PWM techniques are shown in Figs. 9-14. The relation between THD and modulation index as shown in Fig. 15 and harmonic spectrum of two technique are shown in Figs. 16-17.

Compared to the results of the two methods in terms of THD shows that the results of the first method best for the modulation index range from 2.5 to 4.5.

The voltage ripple of the capacitor C1 was reduced when the proposed LPS-PWM method was applied compared with LPS-PWM. Therefore, the losses caused by the voltage reduction of the switched capacitors were low and the efficiency of the inverter was improved.

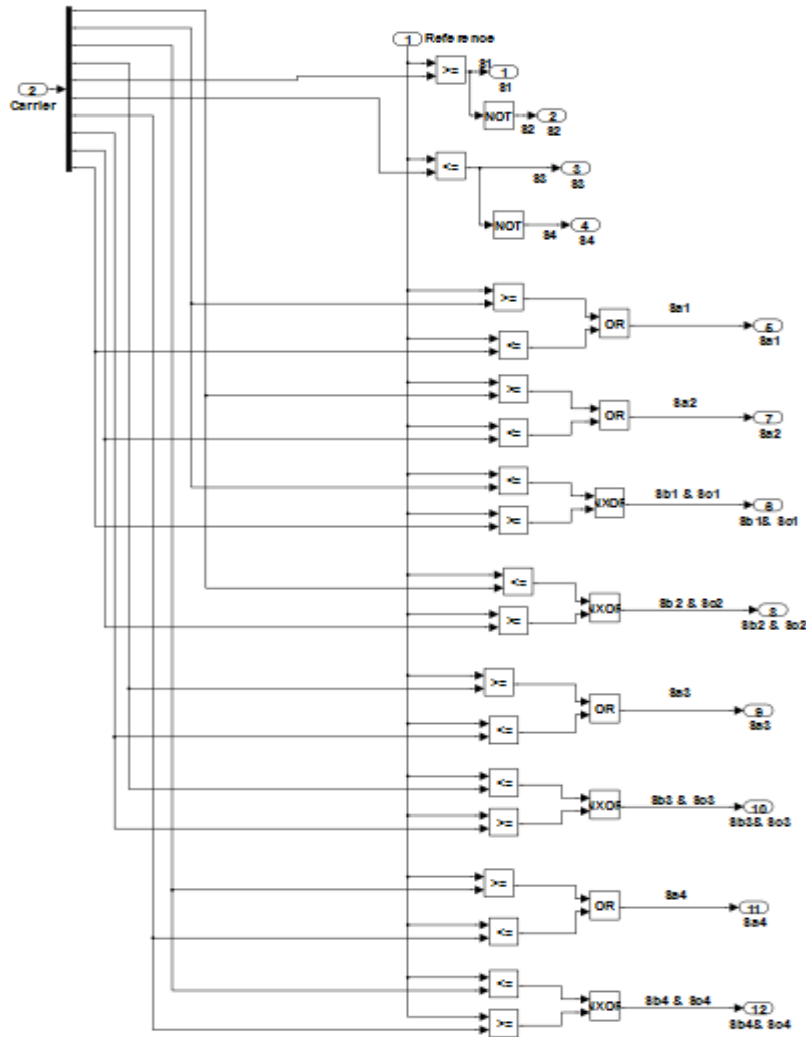

Fig. 8. Block diagram of drive circuit for LPS-PWM technique.

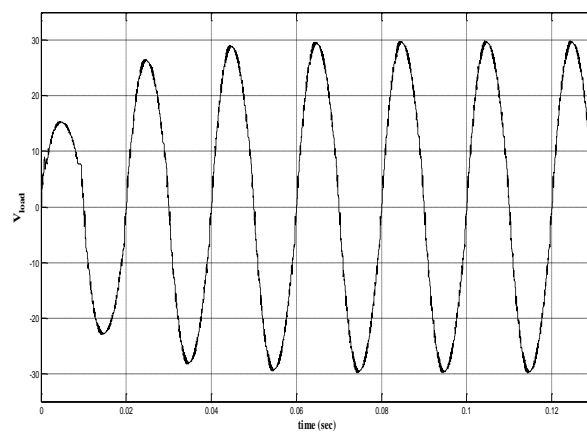

Fig. 9. Load voltage of circuit with LS-PWM technique.

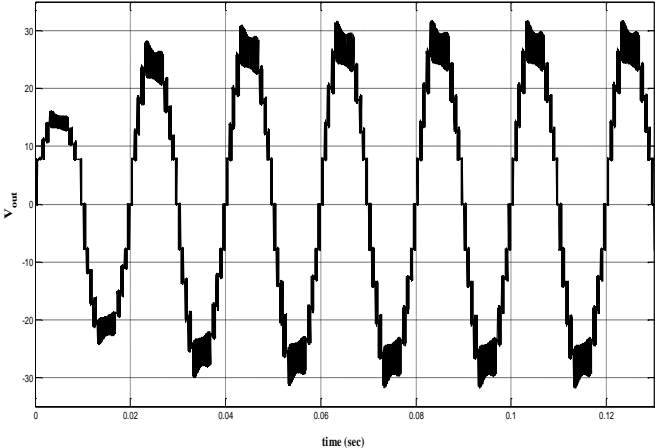

Fig. 10. Output voltage of circuit with LS-PWM technique.

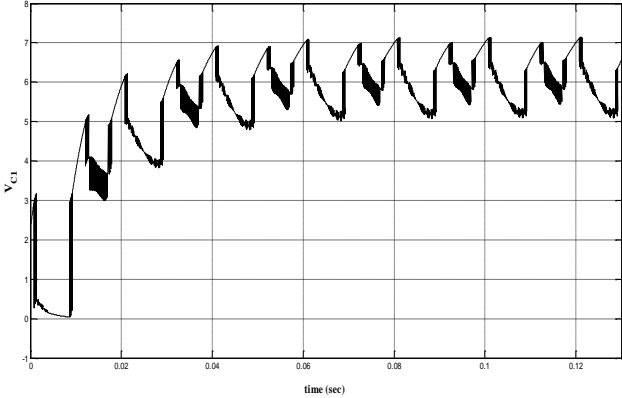

Fig. 11. Capacitor voltage (V_{C1}) of circuit with LS-PWM technique.

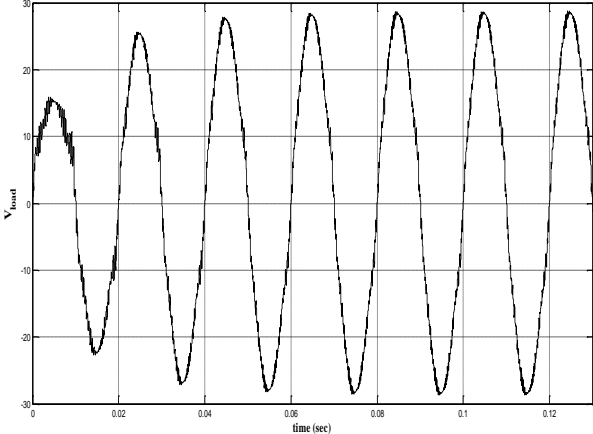

Fig. 12. Load voltage of circuit with LPS-PWM technique.

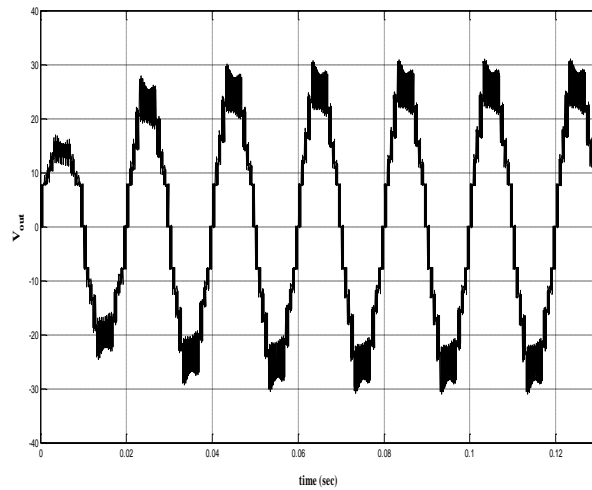

Fig. 13. Output voltage of circuit with LPS-PWM technique.

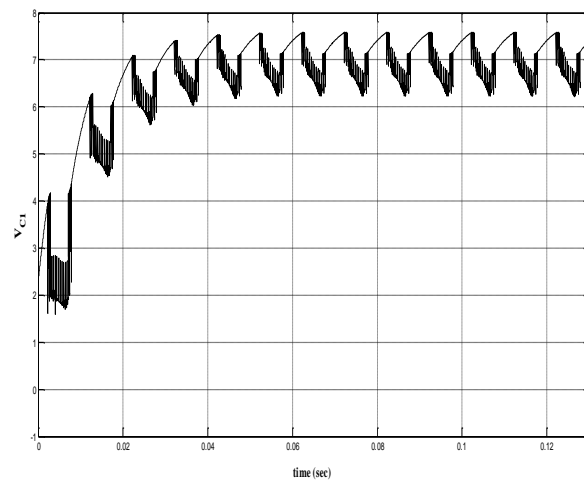

Fig. 14. Capacitor voltage (V_{C1}) of circuit with LPS-PWM technique.

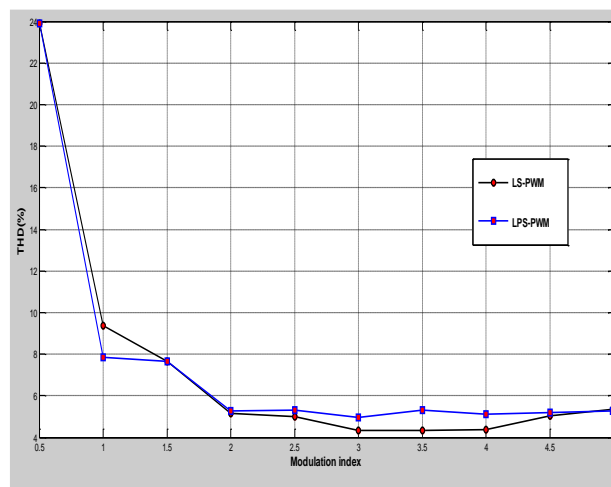

Fig. 15. THD against modulation index for LS-PWM technique.

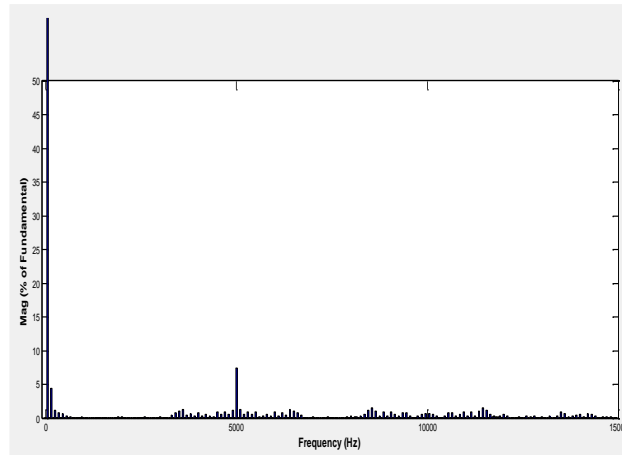

Fig. 16. Harmonic distortion of output voltage for LS-PWM technique.

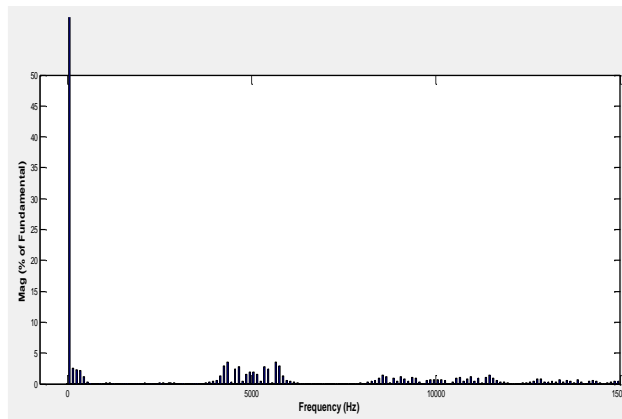

Fig. 17. Harmonic distortion of output voltage for LPS-PWM technique.

6. CONCLUSION

In this paper, a switched-capacitor inverter is suggested. The circuit diagram was introduced and the two modulation methods (LS-PWM and LPS-PWM) were shown. The circuit stage operation of the suggested inverter was promoted by the simulation results with a resistive and inductive load.

The suggested inverter output shows a great voltage than the input voltage by switching the capacitors in series and in parallel.

The framework of the inverter is simpler than the classical switched-capacitor inverters. THD of the output waveform in LPS-PWM technique is reduced compared to the LS-PWM technique.

7. REFERENCES

- Yoo, H., Sul, S. K., Park, Y. and Jeong, J., "System Integration and Power-Flow Management for a Series Hybrid Electric Vehicle Using Supercapacitors and Batteries," *IEEE Trans. on Industry applications*, vol.44, no. 1, pp. 108-114, Jan./Feb..2008.
- Lu, J., Govestan, S., Savaghebi, M., J. Vasquez C. and Guerrero J. M., "An Enhanced State Observer for DC-Link Voltage Control of Three-Phase AC/DC Converters," *IEEE Trans. on power electronics*, pp. 936-942, July 2017.
- Emadi, A., Williamson, S. S., and Khaligh, A., "Power electronics intensive solutions for advanced electric, hybrid electric, and fuel cell vehicular power systems," *IEEE Trans. on Power Electron.*, vol. 21, no. 3, pp. 567–577, May 2006.
- Hu, S., Liang, Z. and He, X., " combined current sensing method for the three-phase quasi-z-source inverter," *IEEE Trans. on Industrial electronics*, vol. 64, Issue 9, pp. 7152-7160, Sept. 2017.
- Voglitsis, D., Papanikolaou, N. and Kyritsis, A.," incorporation of harmonic injection in interleaved flyback inverter for the implementation of an active anti-islanding technique", *IEEE Trans. on Power Electron.*, vol. 32, Issue 11, pp. 8526-843, Nov. 2017.
- Chandrasekaran, S. and Gokdere, L. U., "Integrated magnetics for interleaved DC–DC boost converter for fuel cell powered vehicles," in *Proc. IEEE Power Electron. Spec. Conf.*, pp. 356–361, Jun. 2004.
- Franquelo, L., Rodriguez, J., Leon, J., Kouro, S., Portillo, R., and Prats, M., "The age of multilevel converters arrives," *Industrial Electronics Magazine*, IEEE, vol. 2, no. 2, pp. 28–39, June 2008.
- Karasani, R. R., Borghate, V. B., Meshram, P. M., Suryawanshi, H. M., and Sabyasachi, S., "A three-phase hybrid cascaded modular multilevel inverter for renewable energy environment," *IEEE Transactions on Power Electronics*, vol. 32, no. 2, pp. 1070–1087, Feb 2017.
- Rodriguez, J., Franquelo, L. G., Kouro, S., Leon, J. I., Portillo, R. C., Prats, M. A. M., and Perez, M. A., "Multilevel converters: An enabling technology for high-power applications," *Proc. IEEE*, vol. 97, no. 11, pp. 1786–1817, Nov. 2009.
- Kou, X., Corzine, Familiant, K. A., and Y. L., "A unique fault-tolerant design for flying capacitor multilevel inverter," *IEEE Trans. Power Electron.*, vol. 19, no. 4, pp. 979–987, Jul. 2004.
- Ardashir, J. F., Sabahi, M., Hosseini, S. H., Blaabjerg, F., Babaei, E, and Gharehpetian, G B.," A single-phase transformerless inverter with charge pump circuit concept for grid- tied pv applications," *IEEE Trans. on Industrial electronics*, vol. 64, Issue 7, pp. 5403-5417, July 2017.

Hinago, Y., and Koizumi, H., "A Single-Phase Multilevel Inverter Using Switched Series/Parallel DC Voltage Sources," *IEEE Trans. on Industrial electronics*, vol. 57, no.8, pp. 2643-2650, Aug. 2010.

Fong, Y. C., Cheng, K. W. E., Y. Ye, and Chan, Y. C." centralized regulation scheme for parallel mode switched-capacitor converter system with simple unit commitment," *Trans. on Industrial electronics*, vol. 57, Issue.8, pp. 6148--6158, Aug. 2017.

McGrath, B. P. and Holmes, D. G., "Multicarrier PWM strategies for multilevel inverters," *IEEE Trans. Ind. Electron.*, vol. 49, no. 4, pp. 858–867, Aug. 2002.

Das, S. and Narayanan, G., "Novel switching sequences for a space-vector modulated three-level inverter," *IEEE Trans. Ind. Electron.*, vol. 59, no. 3, pp. 1477–1487, Mar. 2012.

Agelidis, V. G., Balouktsis, A. I., and Cossar, C., "On attaining the multiple solutions of selective harmonic elimination PWM three-level waveforms through function minimization," *IEEE Trans. Ind. Electron.*, vol. 55, no. 3, pp. 996–1004, Mar. 2008.

Hinago, Y. and Koizumi, H., "A modulation method for capacitor voltage ripple reduction of the switched-capacitor inverter using series/ parallel conversion," in *Proc. IEEE Int. Conf. Ind. Technol.*, pp. 105–109, Mar. 2011,